

ORGANIZER

2024



INTERACTIVE  
VERSION

ORGANIZER  
2024

# INDEX

<b>The Company</b>	<i>pag. 10</i>	<b>Engineering</b>	<i>pag. 194</i>
<b>Technology</b>	<i>pag. 12</i>	<b>Pools &amp; Wellness</b>	<i>pag. 196</i>
<b>Sizes</b>	<i>pag. 14</i>	<b>Facades</b>	<i>pag. 198</i>
<b>Thicknesses</b>	<i>pag. 16</i>	<b>Raised Flooring</b>	<i>pag. 202</i>
<b>Surfaces</b>	<i>pag. 18</i>	<b>Technical Specifications</b>	<i>pag. 212</i>
<b>Porcelain stoneware</b>	<i>pag. 20</i>		
<b>Ecologycare</b>	<i>pag. 22</i>		
<b>Certifications</b>	<i>pag. 27</i>		
<b>Quality and Safety</b>	<i>pag. 28</i>		
<b>Ceramic of Italy</b>	<i>pag. 32</i>		
<b>Fincibec Group</b>	<i>pag. 34</i>		
<b>Campus</b>	<i>pag. 36</i>		

## Contents by collection / Indice per collezione

Index par collection - Verzeichnis der Kollektion - Índice por colección

<b>Archè</b>	pag. 86
<b>Ashley</b>	pag. 42
<b>Azimuth</b>	pag. 92
<b>Blade</b>	pag. 160
<b>Charisma</b>	pag. 108
<b>Dicta</b>	pag. 78
<b>Dolomite</b>	pag. 120
<b>Esprit</b>	pag. 152
<b>Evolution</b>	pag. 116
<b>Gamut</b>	pag. 144
<b>Geobrick</b>	pag. 126
<b>Graphis</b>	pag. 168
<b>On Stage</b>	pag. 64
<b>Pietra Castello</b>	pag. 102
<b>Pietre Naturali</b>	pag. 132
<b>Tradition</b>	pag. 136
<b>Transalp</b>	pag. 72
<b>Woodtime</b>	pag. 50
<b>Yukon</b>	pag. 56
<b>Major</b>	pag. 180

## Contents by effect - Indice per effetto

Index par effet - Verzeichnis der effektk - Índice por efecto

<b>WOOD - LEGNO</b> bois - Holz - madera	<b>MARBLE - MARMO</b> marbre - Marmor - marmol	<b>STONE - PIETRA</b> pierre - Stein - piedra	<b>CONCRETE - CEMENTO</b> concret - Konkrete - concreto
<b>Ashley</b> pag. 42	<b>On Stage</b> pag. 64	<b>Dicta</b> pag. 78	<b>Gamut</b> pag. 144
<b>Woodtime</b> pag. 50	<b>Transalp</b> pag. 72	<b>Archè</b> pag. 86	<b>Esprit</b> pag. 152
<b>Yukon</b> pag. 56		<b>Azimuth</b> pag. 92	<b>Blade</b> pag. 160
		<b>Pietra Castello</b> pag. 102	<b>Graphis</b> pag. 168
		<b>Charisma</b> pag. 108	
		<b>Evolution</b> pag. 116	
		<b>Dolomite</b> pag. 120	
		<b>Geobrick</b> pag. 126	
		<b>Pietre Naturali</b> pag. 132	
		<b>Tradition</b> pag. 136	

# Index

- The Company
- Technology
- Sizes
- Thicknesses
- Surfaces
- Porcelain stoneware
- Ecologycare
- Certifications
- Quality and Safety
- Ceramic of Italy
- Fincibec Group
- Campus
- Engineering
- Pools & Wellness
- Facades
- Raised Flooring
- Technical Specifications

## ➤ Contents by collection

Archè	Geobrick
Ashley	Graphis
Azimuth	On Stage
Blade	Pietra Castello
Charisma	Pietre Naturali
Dicta	Tradition
Dolomite	Transalp
Esprit	Woodtime
Evolution	Yukon
Gamut	Major

## ➤ Contents by effect

- WOOD - Legno
- MARBLE - Marmo
- STONE - Pietra
- CONCRETE - Cemento

## ➤ Color Index

Color Index Major 20mm

# Color Index

## WOOD - LEGNO

bois - Holz - maderá

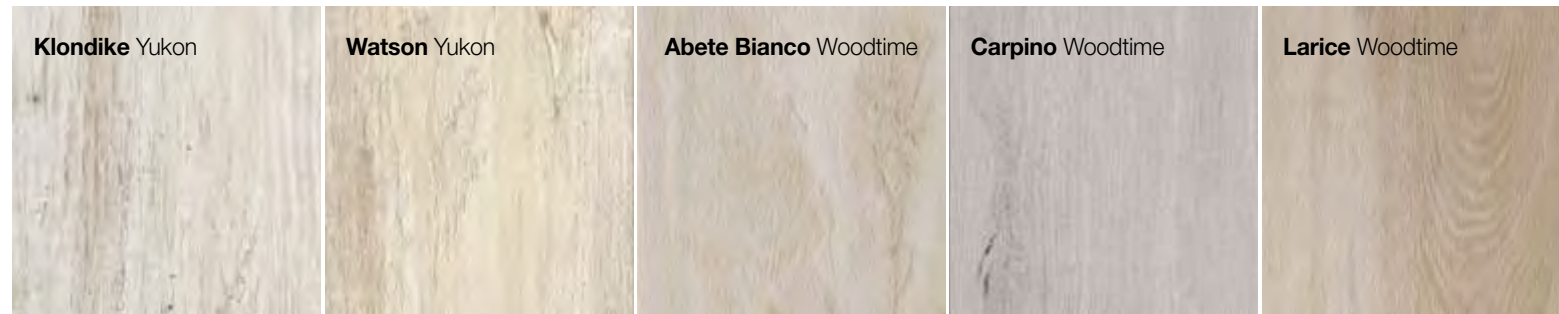

pag. 58

pag. 58

pag. 52

pag. 52

pag. 53

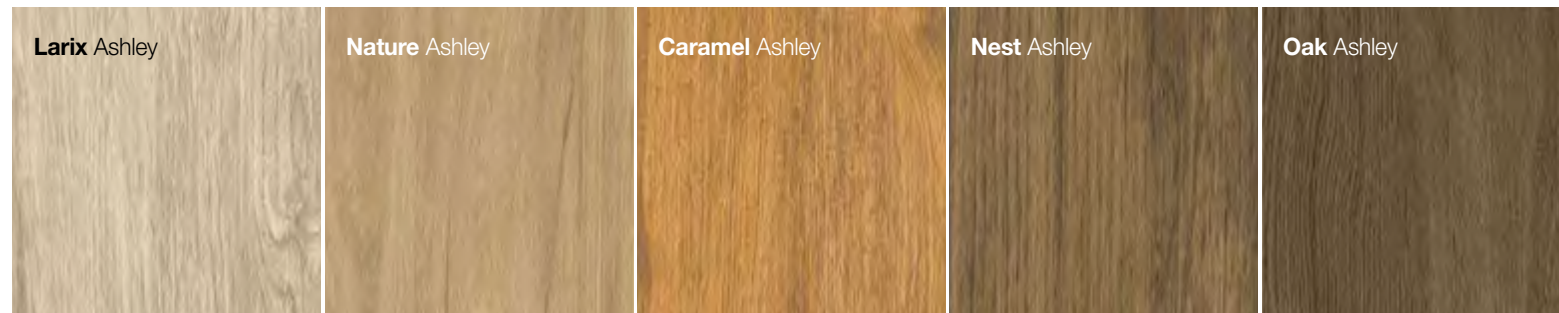

pag. 44

pag. 44

pag. 46

pag. 45

pag. 45

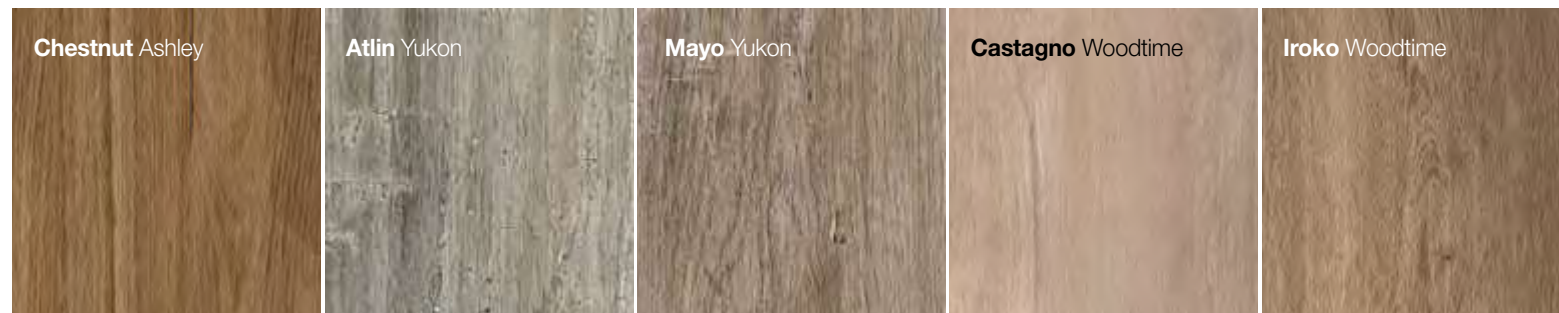

pag. 46

pag. 59

pag. 59

pag. 53

pag. 54

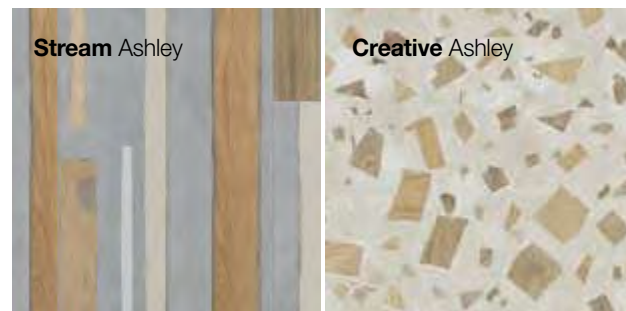

pag. 47

pag. 47

## MARBLE - MARMO

marbre - Marmor - marmol

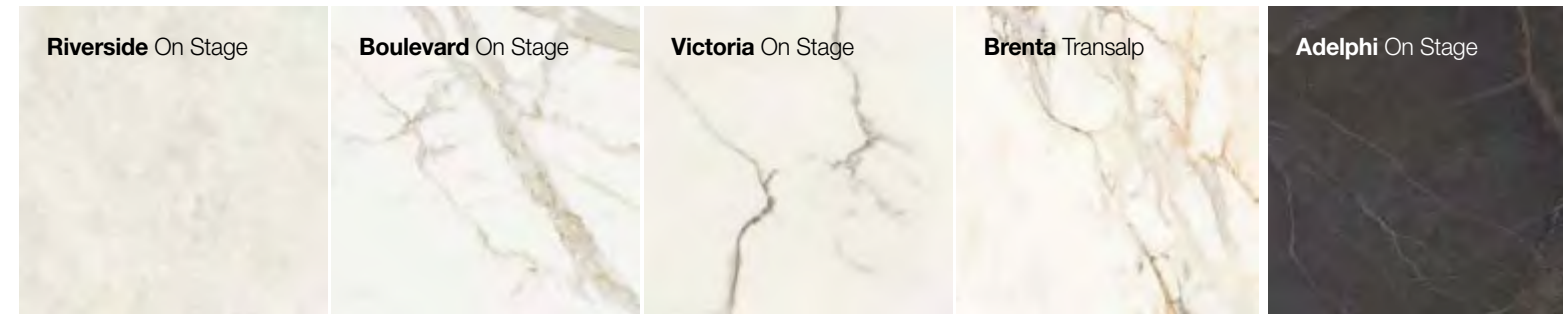

pag. 69

pag. 66

pag. 67

pag. 74

pag. 68

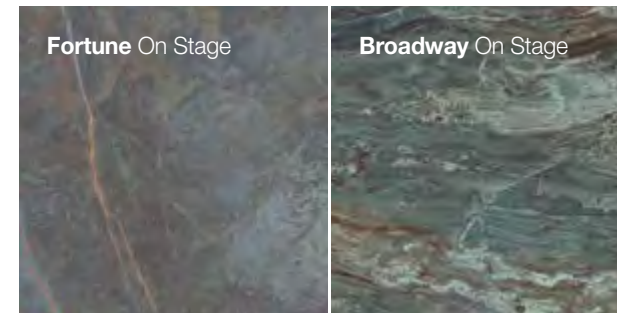

pag. 69

pag. 70

# Index

- The Company
- Technology
- Sizes
- Thicknesses
- Surfaces
- Porcelain stoneware
- Ecologycare
- Certifications
- Quality and Safety
- Ceramic of Italy
- Fincibec Group
- Campus
- Engineering
- Pools & Wellness
- Facades
- Raised Flooring
- Technical Specifications

## > Contents by collection

- |           |                 |
|-----------|-----------------|
| Archè     | Geobrick        |
| Ashley    | Graphis         |
| Azimuth   | On Stage        |
| Blade     | Pietra Castello |
| Charisma  | Pietre Naturali |
| Dicta     | Tradition       |
| Dolomite  | Transalp        |
| Esprit    | Woodtime        |
| Evolution | Yukon           |
| Gamut     | Major           |

## > Contents by effect

- WOOD - Legno
- MARBLE - Marmo
- STONE - Pietra
- CONCRETE - Cemento

## > Color Index

Color Index Major 20mm

# Color Index

## STONE - PIETRA

pierre - Stein - piedra

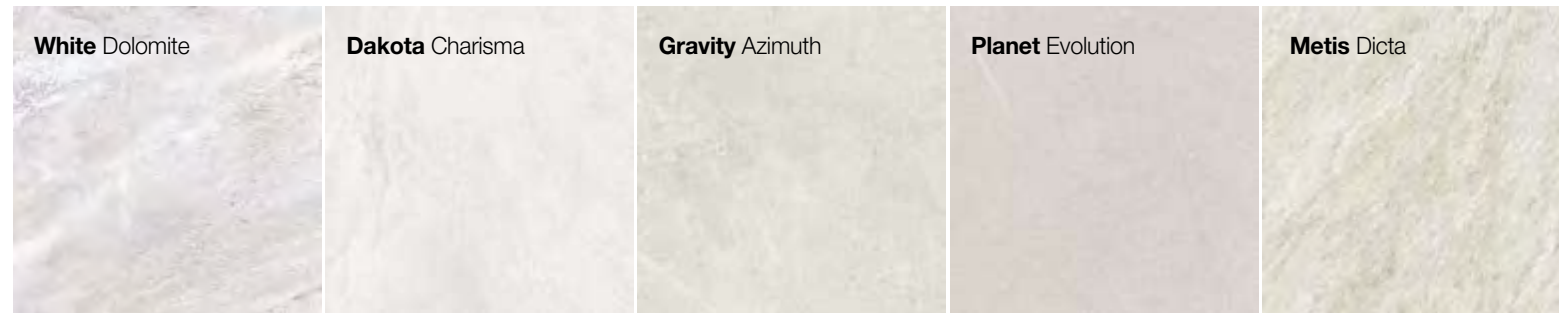

pag. 122      pag. 113      pag. 94      pag. 118      pag. 80



pag. 81      pag. 104      pag. 97      pag. 189      pag. 128

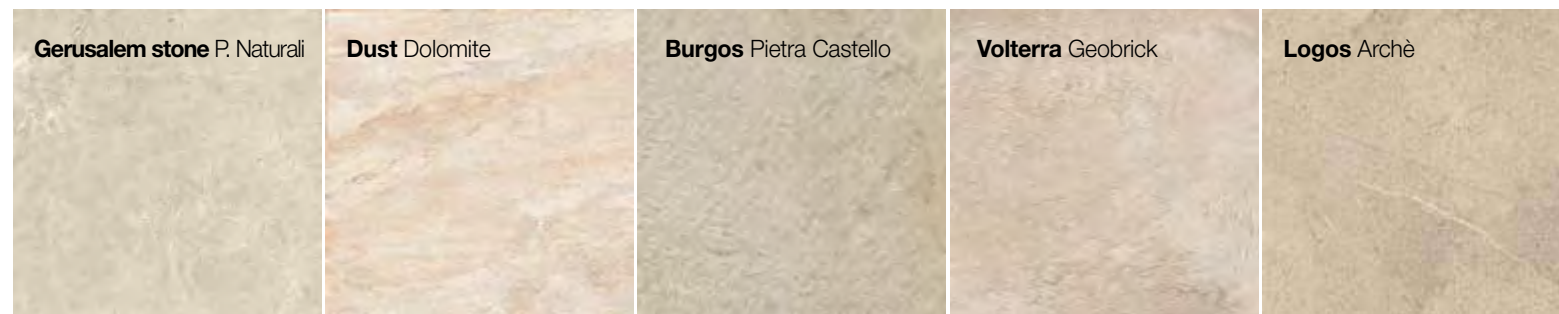

pag. 134      pag. 122      pag. 105      pag. 128      pag. 88

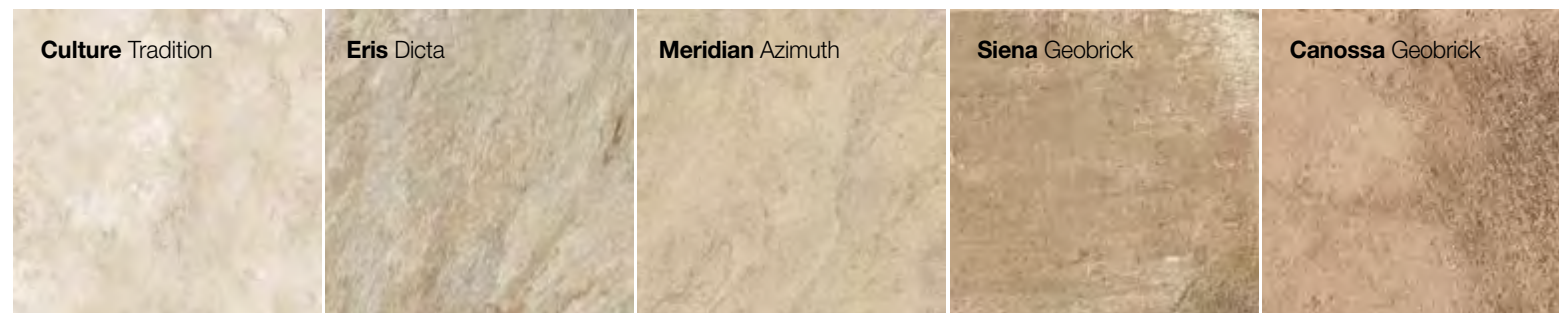

pag. 136      pag. 81      pag. 97      pag. 129      pag. 129

## STONE - PIETRA

pierre - Stein - piedra



pag. 104      pag. 88      pag. 112      pag. 138      pag. 118

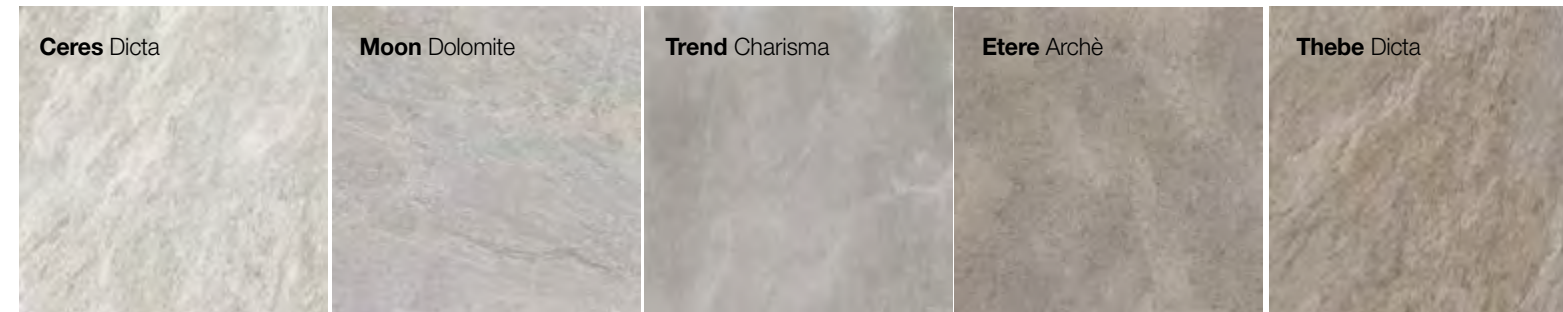

pag. 80      pag. 123      pag. 110      pag. 89      pag. 82



pag. 82      pag. 124      pag. 124      pag. 139      pag. 106

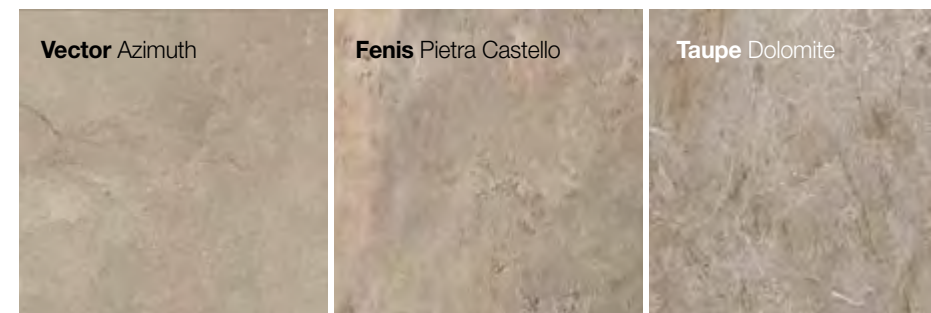

pag. 95      pag. 105      pag. 123

# Index

- The Company
- Technology
- Sizes
- Thicknesses
- Surfaces
- Porcelain stoneware
- Ecologycare
- Certifications
- Quality and Safety
- Ceramic of Italy
- Fincibec Group
- Campus
- Engineering
- Pools & Wellness
- Facades
- Raised Flooring
- Technical Specifications

## > Contents by collection

- |           |                 |
|-----------|-----------------|
| Archè     | Geobrick        |
| Ashley    | Graphis         |
| Azimuth   | On Stage        |
| Blade     | Pietra Castello |
| Charisma  | Pietre Naturali |
| Dicta     | Tradition       |
| Dolomite  | Transalp        |
| Esprit    | Woodtime        |
| Evolution | Yukon           |
| Gamut     | Major           |

## > Contents by effect

- WOOD - Legno
- MARBLE - Marmo
- STONE - Pietra
- CONCRETE - Cemento

## > Color Index

Color Index Major 20mm

# Color Index

## STONE - PIETRA

pierre - Stein - piedra

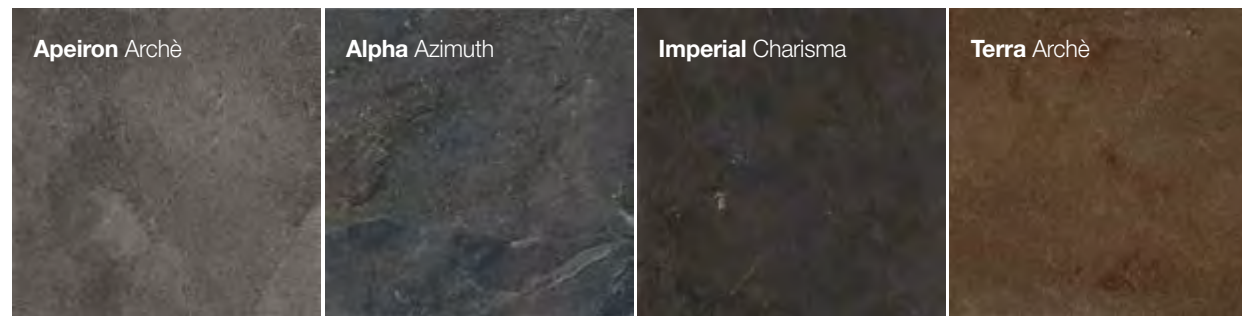

pag. 90

pag. 96

pag. 111

pag. 89

## CONCRETE - CEMENTO

concret - Konkrete - concreto

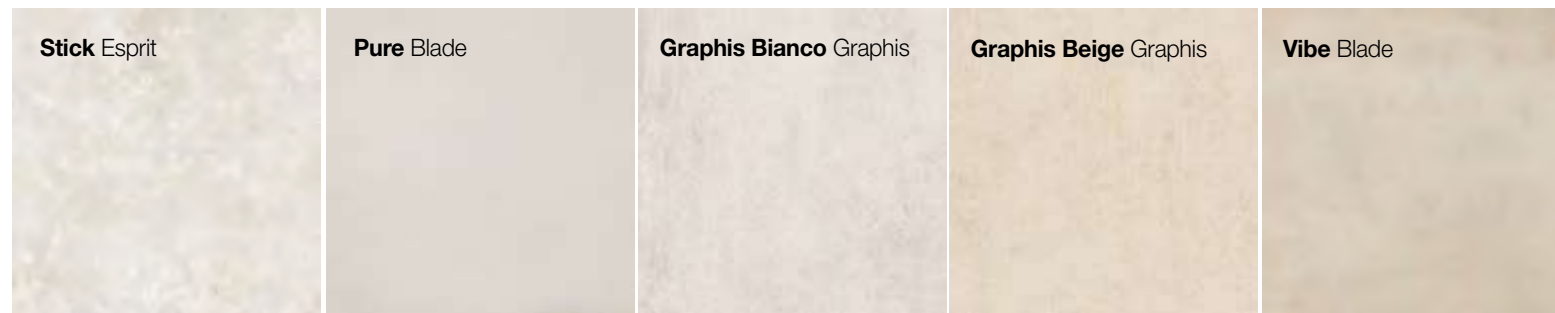

pag. 154

pag. 162

pag. 170

pag. 170

pag. 163

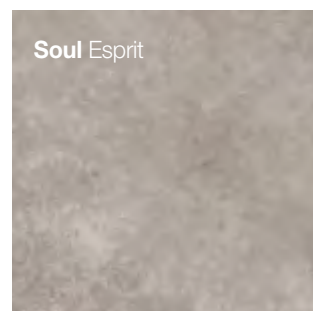

pag. 154

## CONCRETE - CEMENTO

concret - Konkrete - concreto



pag. 146

pag. 171

pag. 146

pag. 171

pag. 157

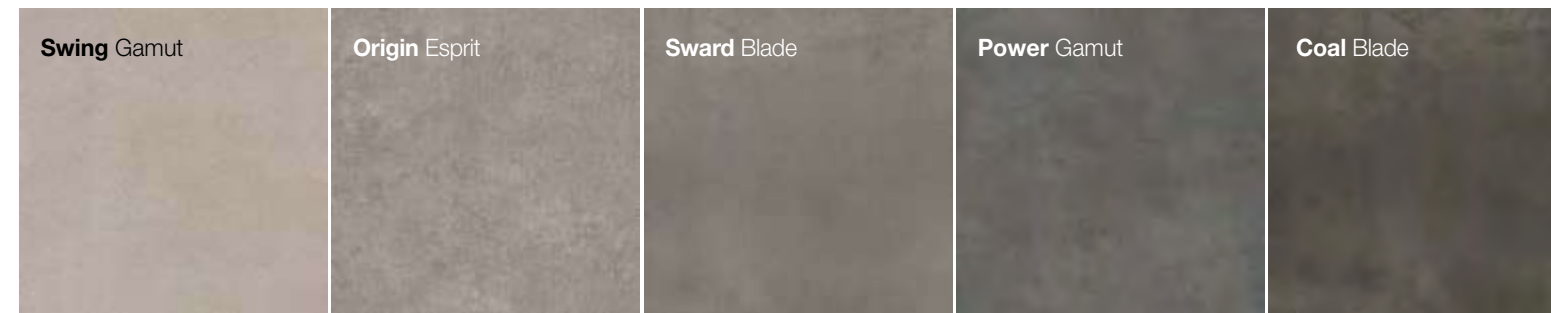

pag. 147

pag. 155

pag. 164

pag. 147

pag. 165

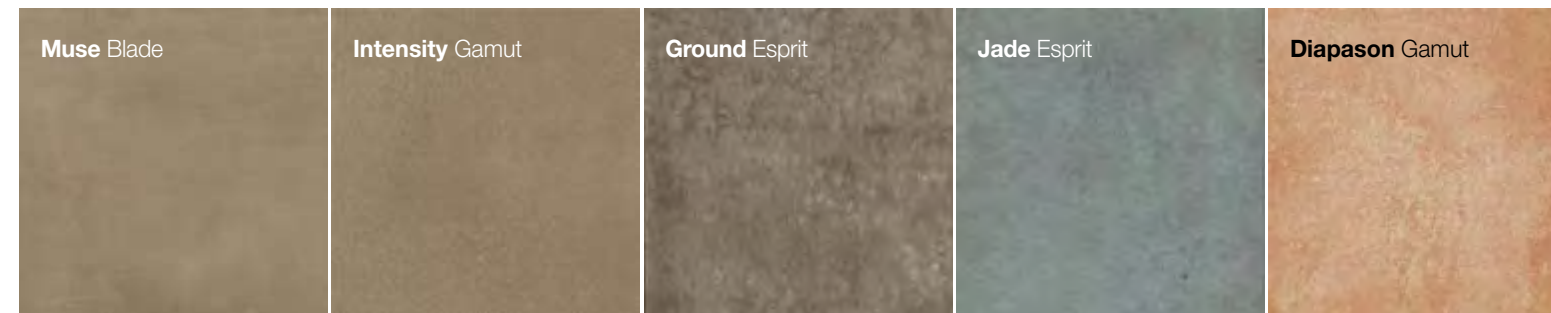

pag. 163

pag. 148

pag. 156

pag. 156

pag. 148

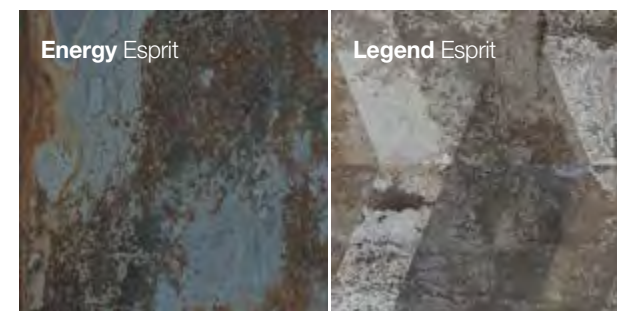

pag. 158

pag. 157

# Index

- The Company
- Technology
- Sizes
- Thicknesses
- Surfaces
- Porcelain stoneware
- Ecologycare
- Certifications
- Quality and Safety
- Ceramic of Italy
- Fincibec Group
- Campus
- Engineering
- Pools & Wellness
- Facades
- Raised Flooring
- Technical Specifications

## > Contents by collection

- |           |                 |
|-----------|-----------------|
| Archè     | Geobrick        |
| Ashley    | Graphis         |
| Azimuth   | On Stage        |
| Blade     | Pietra Castello |
| Charisma  | Pietre Naturali |
| Dicta     | Tradition       |
| Dolomite  | Transalp        |
| Esprit    | Woodtime        |
| Evolution | Yukon           |
| Gamut     | Major           |

## > Contents by effect

- WOOD - Legno
- MARBLE - Marmo
- STONE - Pietra
- CONCRETE - Cemento

## > Color Index

Color Index Major 20mm



## La société

Depuis plus de 60 ans, MONOCIBEC est l'acteur de l'innovation technologique et esthétique du grès cérame à haute résistance pour sols et revêtements et se présente aujourd'hui comme le partenaire idéal des architectes, architectes d'intérieur, décorateurs et utilisateurs finaux pour la conception et de la réalisation de tout type de contexte dans le secteur du bâtiment commercial, technique, public et résidentiel. MONOCIBEC c'est à la fois FORCE ET BEAUTÉ.

## Der Betrieb

MONOCIBEC ist das Markenzeichen, welches seit über 60 Jahren auf dem Bereich der Herstellung von ästhetischen und technisch hochwertigen Bodenfliesen einen grundlegenden Bezugspunkt darstellt. MONOCIBEC bietet dem Markt eine komplette Palette von Kollektionen aus hochwertigem Steingut; innovativ, sowohl in Bezug auf Schönheit als auch auf Vielseitigkeit in der Anwendung.

## La empresa

MONOCIBEC desde hace más de 60 años es protagonista de la innovación tecnológica y estética del grés porcelánico de alta resistencia para suelos y revestimientos y en la actualidad se presenta como socio ideal para arquitectos, interioristas, decoradores y usuarios finales para proyectar y realizar todo tipo de ambientes en edificios comerciales, técnicos, públicos y viviendas residenciales. MONOCIBEC es FUERZA Y BELLEZA.

## The Company

MONOCIBEC has been a leader for more than 60 years in the technological and aesthetic innovation of highly resistant fine porcelain for flooring and surfaces, and currently serves as the ideal partner for architects, interior designers, decorators, and end users in the planning and creation of every kind of commercial, technical, public, and residential space. MONOCIBEC represents STRENGTH AND BEAUTY.

## L'azienda

MONOCIBEC è da oltre 60 anni protagonista della innovazione tecnologica ed estetica del grés porcellanato ad alta resistenza per pavimenti e rivestimenti e si propone oggi come il partner ideale per architetti, interior designer, arredatori ed utilizzatori finali nella progettazione e realizzazione di ogni tipo di ambientazione nell'edilizia commerciale, tecnica, pubblica ed abitativa. MONOCIBEC è forza e bellezza.

### The Company

- Technology
- Sizes
- Thicknesses
- Surfaces
- Porcelain stoneware
- Ecologycare
- Certifications
- Quality and Safety
- Ceramic of Italy
- Fincibec Group
- Campus
- Engineering
- Pools & Wellness
- Facades
- Raised Flooring
- Technical Specifications

### > Contents by collection

Archè	Geobrick
Ashley	Graphis
Azimuth	On Stage
Blade	Pietra Castello
Charisma	Pietre Naturali
Dicta	Tradition
Dolomite	Transalp
Esprit	Woodtime
Evolution	Yukon
Gamut	Major

### > Contents by effect

- WOOD - Legno
- MARBLE - Marmo
- STONE - Pietra
- CONCRETE - Cemento

### > Color Index

Color Index Major 20mm

# Technology, precision, productivity

THE MONOCIBEC PRODUCTS ARE ALL MADE OUT OF FINE PORCELAIN STONEWARE.

One of the feathers in FINCIBEC GROUP'S cap is its wide-ranging use of digital technology and advanced computerisation that allows the control and interconnection of the main production stages, in keeping with the modern concepts of industry 4.0.

# Tecnologia, precisione, produttività

I PRODOTTI MONOCIBEC SONO TUTTI REALIZZATI IN GRES FINE PORCELLANATO.

Uno dei fiori all'occhiello del GRUPPO FINCIBEC è costituito dal diffuso utilizzo delle tecnologie digitali e dalla elevata informatizzazione che consente il controllo e l'interconnessione delle principali fasi produttive in ossequio ai moderni concetti dell'industria 4.0.



## Technologie, précision, productivité

LES PRODUITS MONOCIBEC SONT TOUS FABRIQUÉS EN GRÈS CÉRAME FIN.

L'un des fleurons du GROUPE FINCIBEC est l'utilisation généralisée des technologies numériques et le haut niveau d'informatisation qui permet le contrôle et l'interconnexion des principales phases de production conformément aux concepts modernes de l'industrie 4.0.

## Technologie, Präzision, Produktivität

ALLE MONOCIBEC-ERZEUGNISSE SIND AUS FEINSTEINZEUG HERGESTELLT.

Eines der Aushängeschilder der FINCIBEC-GRUPPE ist der umfassende Einsatz digitaler Technologien sowie die breite Computersteuerung, die die Kontrolle und Verbindung der wichtigsten Produktionsphasen im Einklang mit modernen Konzepten der Industrie 4.0 ermöglichen.

## Tecnología, precisión, productividad

LOS PRODUCTOS MONOCIBEC ESTÁN REALIZADOS EN GRES FINO PORCELÁNICO.

Uno de los emblemas del GRUPO FINCIBEC es el uso generalizado de las tecnologías digitales y el alto nivel de informatización que permite el control e interconexión de las principales fases de producción de acuerdo con los modernos conceptos de la industria 4.0.

# Index

The Company

Technology

Sizes

Thicknesses

Surfaces

Porcelain stoneware

Ecologycare

Certifications

Quality and Safety

Ceramic of Italy

Fincibec Group

Campus

Engineering

Pools & Wellness

Facades

Raised Flooring

Technical Specifications

## Contents by collection

Archè	Geobrick
Ashley	Graphis
Azimuth	On Stage
Blade	Pietra Castello
Charisma	Pietre Naturali
Dicta	Tradition
Dolomite	Transalp
Esprit	Woodtime
Evolution	Yukon
Gamut	Major

## Contents by effect

WOOD - Legno  
 MARBLE - Marmo  
 STONE - Pietra  
 CONCRETE - Cemento

## Color Index

Color Index Major 20mm



# A limitless range

Monocibec follows the daily evolution of architecture and design through an extraordinary array of products that with their outstanding quality, technical and creative facets and sophisticated look reflect the many demands of contemporary design.

# Una gamma senza limiti

Monocibec accompagna quotidianamente l'evoluzione dell'architettura e del design attraverso una straordinaria varietà di prodotti che riflettono nell'eccellenza qualitativa, nelle possibilità tecniche e realizzative e nella raffinatezza estetica, le molteplici esigenze della progettualità contemporanea.

## Une gamme sans limites

Monocibec accompagne quotidiennement l'évolution de l'architecture et du design à travers une extraordinaire variété de produits qui reflètent les nombreuses exigences du design contemporain en termes d'excellence de la qualité, de possibilités techniques et constructives et de raffinement esthétique.

## Eine unbegrenzte Produktpalette

Tag für Tag begleitet Monocibec die Entwicklungen der Architektur und Innenarchitektur mit einer außerordentlichen Vielfalt an Produkten, die mit ihrer herausragenden Qualität, ihren technischen Möglichkeiten und ihrer auserlesenen Ästhetik die zahlreichen zeitgenössischen Planungsanforderungen erfüllen.

## Una gama sin límites

Monocibec acompaña diariamente la evolución de la arquitectura y el diseño a través de una extraordinaria variedad de productos que reflejan las múltiples exigencias del diseño contemporáneo en cuanto a la excelencia de la calidad, las posibilidades técnicas y de construcción y el refinamiento estético.

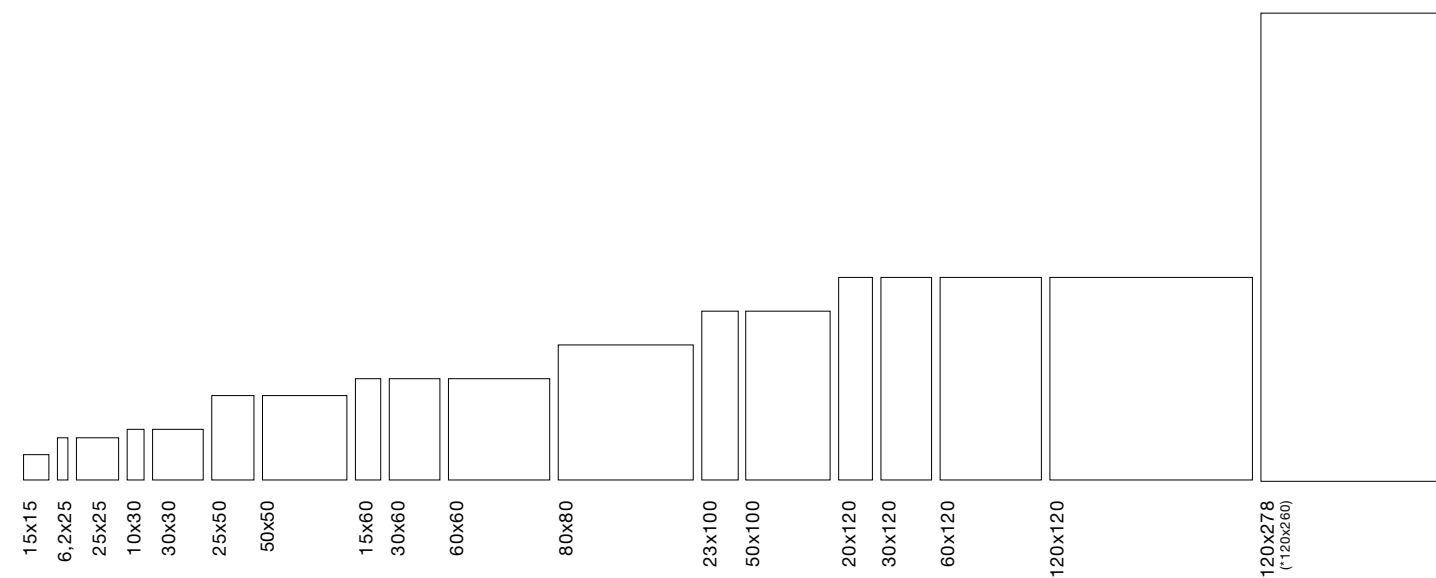

Modularity and a variety of sizes are characteristics of all Monocibec collections, conceived to exalt the different material inspirations. Ranging from the large 120x120 and 60x120-cm to the small 10x30-cm brick format, with particularly versatile sizes like 80x80 cm, you can come up with infinite floor or wall laying options, and try never-before-seen material and colour pairings.

The 120x278-cm slabs increase your options for using porcelain stoneware even outside the scope of conventional floor and wall covering. The made-to-measure personalisation of furnishing and design elements goes hand-in-hand with the elegance of the Monocibec collections, always abreast of the latest style trends.

Every line has matching decorative elements like mosaics, slats and original graphical ideas. Plus, a vast array of special items for designing down to the very last detail, from the most simple like skirting and steps, to the more complex and specific for pools and wellness areas.

La modularité et la variété des formats sont les caractéristiques de toutes les collections Monocibec, conçues pour mettre en valeur les différentes inspirations matérielles. Des grands carreaux de 120x120 et 60x120 cm au petit carreau de 10x30 cm, avec la présence de formats particulièrement polyvalents comme le 80x80 cm, il est possible de créer une infinité de solutions de pose de sols et de murs et d'étudier de nouvelles combinaisons de matériaux et de couleurs.

Les dalles de 120x278 cm étendent les possibilités d'utilisation du grès cérame à d'autres domaines que les revêtements de sol et de mur traditionnels. La personnalisation des éléments de design et d'ameublement, sur mesure, trouve dans l'élégance des collections Monocibec un partenaire toujours attentif aux dernières tendances stylistiques.

Dans chaque série, il y a des éléments décoratifs coordonnés, tels que des mosaïques, des bandes et des propositions graphiques originales. En outre, une large disponibilité de pièces spéciales pour soigner chaque détail du projet, des plus simples comme les plinthes et les marches, aux plus complexes et spécifiques pour les piscines et les espaces de bien-être.

Modularität und Formatvielfalt sind Kennzeichen aller Monocibec-Kollektionen, die unterschiedliche Materialinspirationen gestalten. Von großformatigen Fliesen 120x120 und 60x120 bis zum kleinen Backsteinformat 10x30 und besonders vielseitigen Formaten wie 80x80 ermöglicht das Angebot unendlich viele Lösungen für Bodenbeläge und Wandverkleidungen sowie ausgefallene Material- und Farbkombinationen.

Zudem erweitern die großen Platten im Format 120x278 die Verwendungsmöglichkeiten des Feinsteinzeugs auch über den traditionellen Bereich der Boden- und Wandverkleidung hinaus. Die persönliche Gestaltung von Design- und Einrichtungs-elementen nach Maß findet in den eleganten Kollektionen von Monocibec einen Partner, der die jüngsten stilistischen Trends aufmerksam verfolgt.

Jede Serie umfasst aufeinander abgestimmte Dekorationselemente wie Mosaik, Zierstreifen und originelle grafische Realisierungen. Ferner sind vielfältige Sonderstücke erhältlich, um jede Einzelheit des Entwurfs zu verwirklichen, seien es einfache wie Fußleisten und Stufen oder komplexere und spezifische für Swimmingpools und Wellnessbereiche.

Modularità e varietà dei formati sono caratteristiche di tutte le collezioni Monocibec, studiate per esaltare le differenti ispirazioni materiche. Spaziando dai grandi 120x120 e 60x120 cm fino al piccolo mattoncino 10x30 cm, con la presenza di formati particolarmente versatili come l'80x80 cm, è possibile ideare infinite soluzioni di posa a pavimento e in parete, e studiare inediti abbinamenti materici e cromatici.

Le lastre di 120x278 cm ampliano le possibilità di utilizzo del gres porcellanato anche ad ambiti diversi dal tradizionale rivestimento di pavimenti e pareti. La personalizzazione di elementi di design e di arredamento, realizzati su misura, trova nell'eleganza delle collezioni Monocibec un partner sempre attento alle più recenti tendenze stilistiche.

In ogni serie sono presenti elementi decorativi coordinati, come mosaici, listelli e proposte grafiche originali. Inoltre, una vasta disponibilità di pezzi speciali per curare ogni dettaglio del progetto, da quelli più semplici come battiscopa e gradini, a quelli più complessi e specifici per piscine e aree wellness.

La modularidad y la variedad de formatos son características de todas las colecciones Monocibec, diseñadas para mejorar las diferentes inspiraciones de materiales. Desde los grandes formatos de 120x120 y 60x120 cm hasta el pequeño ladrillo de 10x30 cm, con la presencia de formatos particularmente versátiles como el 80x80 cm, es posible crear infinitas soluciones para la instalación en el suelo y en la pared, y estudiar nuevas combinaciones de materiales y colores.

Las placas de 120x278 cm amplían las posibilidades de utilizar el gres porcelánico a zonas distintas de los revestimientos tradicionales de suelos y paredes. La personalización de los elementos de diseño y decoración, hechos a medida, encuentra en la elegancia de las colecciones Monocibec un partner siempre atento a las últimas tendencias estilísticas.

En cada serie hay elementos decorativos coordinados, como mosaicos, listones y propuestas gráficas originales. Además, una amplia disponibilidad de piezas especiales para cuidar todos los detalles del proyecto, desde los más simples como zócalos y escalones, hasta los más complejos y específicos para piscinas y áreas wellness.

\* 120x260 after out of stock / fino ad esaurimento scorte / jusqu'à épuisement des stocks / hasta agotar el stock / solange der Vorrat reicht

# Index

- The Company
- Technology
- Sizes**
- Thicknesses
- Surfaces
- Porcelain stoneware
- Ecologycare
- Certifications
- Quality and Safety
- Ceramic of Italy
- Fincibec Group
- Campus
- Engineering
- Pools & Wellness
- Facades
- Raised Flooring
- Technical Specifications

## Contents by collection

- |           |                 |
|-----------|-----------------|
| Archè     | Geobrick        |
| Ashley    | Graphis         |
| Azimuth   | On Stage        |
| Blade     | Pietra Castello |
| Charisma  | Pietre Naturali |
| Dicta     | Tradition       |
| Dolomite  | Transalp        |
| Esprit    | Woodtime        |
| Evolution | Yukon           |
| Gamut     | Major           |

## Contents by effect

- WOOD - Legno
- MARBLE - Marmo
- STONE - Pietra
- CONCRETE - Cemento

## Color Index

Color Index Major 20mm

A limitless range - Una gamma senza limiti  
Une gamme sans limites - Eine unbegrenzte Produktpalette - Una gama sin limites

7 mm

20 mm

9 mm  
10 mm

MONOCIBEC PORCELAIN STONEWARE HAS SPREAD TO EVER MORE VAST AND SPECIFIC SCOPES OF APPLICATION THANKS TO A RANGE OF PRODUCTS WITH DIFFERENT THICKNESSES, SUITED TO THE INTENDED USES.

IL GRES PORCELLANATO MONOCIBEC HA CONQUISTATO AMBITI DI UTILIZZO SEMPRE PIÙ VASTI E SPECIFICI, ATTRAVERSO UNA GAMMA PRODOTTI CON SPESSORI DIFFERENTI, IDONEI ALLE DESTINAZIONI D'USO DESIDERATE.

LE GRES CERAME MONOCIBEC A CONQUIS DES DOMAINES D'UTILISATION DE PLUS EN PLUS LARGES ET SPECIFIQUES, GRACE A UNE GAMME DE PRODUITS DE DIFFERENTES EPAISSEURS, ADAPTES AUX UTILISATIONS SOUHAITEES.

DANK EINER PRODUKTPALETTE MIT VERSCHIEDENEN STÄRKEN, DIE FÜR DIE GEWÜNSCHTEN NUTZUNGEN GEEIGNET SIND, HAT DAS FEINSTEINZEUG VON MONOCIBEC IMMER UMFÄNGLICHERE VERWENDUNGSBEREICHE EROBERT.

EL GRES PORCELÁNICO MONOCIBEC HA CONQUISTADO ÁMBITOS DE UTILIZACIÓN CADA VEZ MÁS AMPLIOS Y ESPECÍFICOS, MEDIANTE UNA GAMA DE PRODUCTOS DE DIFERENTES ESPESORES, ADECUADOS PARA LOS USOS DESEADOS.

THICKNESSES - SPESSORI - EPAISSEURS - DICKEN - ESPESORES

organizer 2024

**7 mm** of strength and lightness in the most innovative surfaces for architecture and design. The small thickness of the slabs lets you use them both for covering and to create original, personalised elements. Kitchen and bathroom counter tops, tables and coffee tables, desks, but also shelves and doors can be made out of porcelain stoneware.

**9 mm** is the thickness used for the more conventional-sized range. Strength, versatility and certified quality mainly geared towards floor and wall covering in any scope of application, from residential to commercial and public.

**10 mm** of strength for the thickness of the grip surfaces designed for outdoor flooring. Frost-proof and non-absorbent, porcelain stoneware for outdoor applications enhances solutions that recall the aesthetics of natural materials, offering excellent performance even in wellness areas and around swimming pools.

**20 mm** is the thickness that combined with the grip surface creates super high-performance products for building walkways and equipped areas in outdoor spots. Such a large width also gives you options for dry laying and laying on raised supports, besides conventional laying on screed.

**7 mm** de résistance et de légèreté dans les surfaces les plus innovantes pour l'architecture et le design. L'épaisseur limitée des tôles permet à la fois l'utilisation pour le revêtement et l'utilisation pour créer des éléments originaux et personnalisés. Les plans de travail des cuisines et des salles de bain, les tables et les tables basses, les bureaux, mais aussi les étagères et les portes peuvent être en grès cérame.

**9 mm** est l'épaisseur adoptée pour la gamme de taille plus traditionnelle. Résistance, polyvalence et qualité certifiée principalement destinées aux revêtements de sol et muraux dans tout domaine d'utilisation, du résidentiel au commercial et au public.

**10 mm** de résistance pour l'épaisseur des surfaces grip conçues pour les revêtements de sol extérieurs. Antigel et non absorbant, le grès cérame pour extérieur met en valeur, avec cette épaisseur, les solutions qui rappellent l'esthétique des matières naturelles tout en offrant des performances d'excellence même dans les espaces bien-être et au bord des piscines.

**20 mm** est l'épaisseur qui permet de créer, en combinaison avec la surface d'adhérence, des produits de haute performance pour créer des passages et des zones équipées dans les espaces extérieurs. Une épaisseur aussi importante permet également des solutions pour la pose à sec et sur des supports surélevés, en plus de la pose traditionnelle sur chape.

**7 mm** di forza e leggerezza nelle superfici più innovative, destinate all'architettura e al design. Lo spessore contenuto delle lastre consente sia l'utilizzo per rivestimenti che l'impiego per creare elementi originali e personalizzati. Piani di lavoro per cucine e bagni, tavoli e tavolini, scrivanie, ma anche scaffali e porte possono essere realizzati in gres porcellanato.

**9 mm** è lo spessore adottato per la gamma formati più tradizionale. Resistenza, versatilità e qualità certificata destinate prevalentemente al rivestimento di pavimenti e di pareti in qualsiasi ambito di utilizzo, dal residenziale al commerciale e pubblico.

**10 mm** di resistenza per lo spessore delle superfici grip studiate per le pavimentazioni esterne. Ingelivo e inassorbente, il gres porcellanato per l'outdoor valorizza con questo spessore le soluzioni che richiamano l'estetica di materiali naturali, offrendo performance d'eccellenza anche nelle aree wellness e a bordo piscina.

**20 mm** è lo spessore che crea, in combinazione con la superficie grip, prodotti dalle prestazioni elevatissime per realizzare camminamenti e aree attrezzate negli spazi esterni. Uno spessore così importante permette inoltre soluzioni di posa a secco e su supporti sopraelevati, oltre alla tradizionale posa su massetto.

**7 mm** Stärke und Leichtigkeit für innovative Oberflächen in Innenarchitektur und Design. Die geringe Stärke gestattet die Verwendung sowohl für Verkleidungen als auch zur Schaffung persönlich gestalteter, origineller Elemente. Arbeits- und Abstellflächen für Küchen und Bäder, kleine und größere Tische, Schreibtische, aber auch Regale und Türen lassen sich mit Feinsteinzeug gestalten.

**9 mm** ist die Stärke, die für das Angebot an traditionelleren Formaten verwendet wird. Widerstandsfähigkeit, Vielseitigkeit und zertifizierte Qualität, die vorwiegend zur Boden- und Wandverkleidung in allen Verwendungsbereichen, vom Wohnungsbereich bis zu gewerblichen und öffentlichen Gebäuden, bestimmt sind.

**10 mm** Stärke für eine absolute Beständigkeit dieser Produkte, die für die Verlegung im Freien bestimmt sind. Das frostbeständige und nicht absorbierende Feinsteinzeug für den Außenbereich ermöglicht Lösungen, die an die Optik natürlicher Materialien erinnern und bietet auch in Wellnessbereichen und rund um Schwimmbäder hervorragende Performance.

**20 mm** ist die Stärke, die zusammen mit der rutschfesten Oberfläche für Produkte mit sehr hoher Leistung zur Realisierung von Wegen und Flächen im Außenbereich kennzeichnend ist. Eine so bedeutende Stärke erlaubt neben der traditionellen Verlegung auf Estrich auch Lösungen mit Trockenverlegung und Verlegung auf Doppelböden.

**7 mm** de resistencia y ligereza en las superficies más innovadoras, pensadas para arquitectura y diseño. El espesor limitado de las placas permite tanto el uso para el revestimiento como el uso para crear elementos originales y personalizados. Las encimeras de las cocinas y los baños, las mesas y las mesitas de café, los escritorios, pero también los estantes y las puertas pueden ser de gres porcelánico.

**9 mm** es el espesor adoptado para la gama de formatos más tradicional. Resistencia, versatilidad y calidad certificada destinadas principalmente al revestimiento de suelos y paredes en cualquier ámbito de uso, desde el residencial hasta el comercial y el público.

**10 mm** de resistencia para el grosor de las superficies grip diseñadas para pavimentos de exterior. Un gres porcelánico para exteriores, resistente a las heladas y no absorbente, que con este grosor presenta soluciones que recuerdan el aspecto de los materiales naturales, ofreciendo excelentes prestaciones incluso en piscinas y zonas de spa.

**20 mm** es el espesor que crea, en combinación con la superficie grip, productos con unas prestaciones muy elevadas para realizar pasillos y áreas equipadas en espacios externos. Un grosor tan importante también permite soluciones para la colocación en seco y en sustratos elevados, además de la colocación tradicional en soleras.

# Index

The Company

Technology

Sizes

Thicknesses

Surfaces

Porcelain stoneware

Ecologycare

Certifications

Quality and Safety

Ceramic of Italy

Fincibec Group

Campus

Engineering

Pools & Wellness

Facades

Raised Flooring

Technical Specifications

## Contents by collection

Archè	Geobrick
Ashley	Graphis
Azimuth	On Stage
Blade	Pietra Castello
Charisma	Pietre Naturali
Dicta	Tradition
Dolomite	Transalp
Esprit	Woodtime
Evolution	Yukon
Gamut	Major

## Contents by effect

WOOD - Legno  
MARBLE - Marmo  
STONE - Pietra  
CONCRETE - Cemento

## Color Index

Color Index Major 20mm

A limitless range - Una gamma senza limiti  
 Une gamme sans limites - Eine unbegrenzte Produktpalette - Una gama sin limites



SURFACES - SUPERFICI - SURFACES - OBERFLÄCHEN - SUPERFICIES

organizer 2024

# Index

The Company

Technology

Sizes

Thicknesses

**Surfaces**

Porcelain stoneware

Ecologycare

Certifications

Quality and Safety

Ceramic of Italy

Fincibec Group

Campus

Engineering

Pools & Wellness

Facades

Raised Flooring

Technical Specifications

## ➤ Contents by collection

Archè	Geobrick
Ashley	Graphis
Azimuth	On Stage
Blade	Pietra Castello
Charisma	Pietre Naturali
Dicta	Tradition
Dolomite	Transalp
Esprit	Woodtime
Evolution	Yukon
Gamut	Major

## ➤ Contents by effect

WOOD - Legno
MARBLE - Marmo
STONE - Pietra
CONCRETE - Cemento

## ➤ Color Index

Color Index Major 20mm

## THE MONOCIBEC CERAMIC COLLECTIONS INTERPRET NUMEROUS MATERIAL AND GRAPHIC INSPIRATIONS, CONCEIVED DIFFERENTLY IN A BROAD RANGE OF SURFACES THAT EXALT THE PRODUCT'S LOOK.

LE COLLEZIONI CERAMICHE MONOCIBEC  
 INTERPRETANO NUMEROSE ISPIRAZIONI  
 MATERICHE E GRAFICHE, DECLINANDOLE  
 IN UNA VASTA GAMMA DI SUPERFICI IN  
 GRADO DI ESALTARE L'ESTETICA DEL PRODOTTO.

LES COLLECTIONS DE CERAMIQUES  
 MONOCIBEC INTERPRETENT DE  
 NOMBREUSES INSPIRATIONS  
 MATERIELLES ET GRAPHIQUES,  
 DECLINEES DANS UNE LARGE GAMME  
 DE SURFACES CAPABLES DE METTRE  
 EN VALEUR L'ESTHETIQUE DU PRODUIT.

DIE KERAMIK-KOLLEKTIONEN VON  
 MONOCIBEC GREIFEN ZAHLREICHE  
 MATERIAL- UND GRAFIKINSPIRATIONEN  
 AUF UND INTERPRETIEREN SIE IN EINER  
 BREITEN AUSWAHL AN FLÄCHEN, DIE  
 DIE ÄSTHETIK DES PRODUKTS ZUR  
 GELTUNG BRINGEN.

LAS COLECCIONES DE CERÁMICA  
 MONOCIBEC INTERPRETAN  
 NUMEROSAS INSPIRACIONES  
 MATERIALES Y GRÁFICAS, DECLINADAS  
 EN UNA AMPLIA GAMA DE SUPERFICIES  
 CAPACES DE MEJORAR LA ESTÉTICA  
 DEL PRODUCTO.

**Naturel**  
 La finition naturelle permet de capturer l'essence matérielle originale du produit. Résistante et polyvalente, cette surface convient à l'installation au sol et au mur dans les espaces résidentiels, commerciaux et publics à forte fréquentation.

**Soft**  
 La finition soft se caractérise par une versatilité similaire à celle de la finition naturelle; conçue pour donner au grès cérame un aspect doux et satiné, cette finition est indiquée pour les murs et les sols dans les milieux résidentiels et commerciaux, après avoir dûment vérifié les sollicitations et les spécifications prévues.

**Rodage et Adouciment**  
 Le rodage et le adouciment sont des procédés spéciaux sur la surface de la céramique capables de produire un effet brillant léger mais continu qui suit uniformément la structure du matériau. Ces surfaces sont appréciées comme un élément de décoration intérieure au style polyvalent, adapté à la fois aux contextes historiques et au dialogue avec l'architecture contemporaine. Idéaux à l'intérieur, dans les immeubles résidentiels, tant pour les sols que pour les murs, les matériaux céramiques rodés peuvent également être utilisés dans les espaces commerciaux et publics à trafic moyen.

**Polie**  
 Le grès cérame à la surface polie prend l'éclat d'un miroir, mettant en valeur les couleurs et les veines des matériaux inspirés de l'effet marbre. La brillance des produits polis suggère leur utilisation pour le revêtement mural, pour la création de sols dans les espaces intérieurs des zones résidentielles et, avec des contrôles appropriés sur les contraintes prévues, dans les zones commerciales légères.

**Grip**  
 La surface Grip est la bonne combinaison d'esthétique, de fiabilité et de sécurité. Elle convient à la construction de sols dans les zones extérieures, les espaces publics et commerciaux et les passages dans les zones privées où des exigences spécifiques sont requises.

**Natural**  
 The natural finish lets you capture the product material's original essence of the surface. Recommended for use on floors and walls in residential, commercial and high traffic public spaces.

**Soft**  
 The soft finish offers a versatility similar to that of a natural finish and has been designed to give the tile a soft, satiny appearance. It can be used for walls and floors in residential and commercial settings, subject to checks on specifications and resistance to stress.

**Lapped and brushed**  
 Lapping and brushing are special ways of working the ceramic surface to produce a slight but continuous glossy effect which evenly underlines the material's structure. These surfaces are appreciated as elements of interior design with a versatile style suitable for both historic buildings and contemporary architecture. Ideal for interior use covering walls and floors in the home, lapped ceramic materials are also appropriate for use in commercial and public medium foot traffic spaces.

**Polished**  
 Porcelain stoneware with a polished surface takes on a mirror sheen, underlining the colours and veining of the materials inspiring it and creating a marble effect. The gloss of polished porcelain stoneware suggests use as a wall covering, for indoor flooring in the home and, after determining the expected levels of stress, in commercial spaces not subject to heavy traffic.

**Grip**  
 The Grip surface offers the perfect combination of beauty, dependability and safety for outdoor pavements, public and commercial spaces, and residential pathways requiring specific requisites.

**Naturbelassen**  
 Bei der naturbelassenen Ausführung lässt sich die ursprüngliche materielle Essenz des Produkts erkennen. Diese widerstandsfähige und vielseitige Oberfläche ist für die Boden- und Wandverlegung in Wohnräumen, gewerblichen und öffentlichen Bereichen mit hohem Personenverkehr geeignet.

**Soft**  
 Die Soft-Ausführung, die durch eine Vielseitigkeit gekennzeichnet ist, die jener der naturbelassenen Ausführung ähnlich ist, verleiht der Keramik ein besonders weiches Aussehen und eignet sich - unter entsprechender Überprüfung der vorgesehenen Beanspruchungen und Spezifikationen - als Wandverkleidung und Bodenbelag für Wohn- und Gewerbebereiche.

**Geläppt und geschliffen**  
 Das Läppen und Schleifen sind besondere Bearbeitungen von Keramikoberflächen, die einen leichten, aber anhaltenden Glanz erzeugen, der die Materialstruktur einheitlich hervortreten lässt. Solche Oberflächen werden als vielseitiges Inneneinrichtungselement geschätzt, das sich sowohl an traditionelle Kontexte als auch an die zeitgenössische Architektur anpasst. Ideal für die Realisierung von Bodenbelägen und Wandverkleidungen im Wohnungsbau, eignet sich geläpptes Keramikmaterial auch für die Verwendung im gewerblichen und öffentlichen Räume mit mittlerem Verkehr.

**Poliert**  
 Poliertes Feinsteinzeug gewinnt den Glanz eines Spiegels und unterstreicht die Farbtöne und Aderungen von Fliesen mit Marmoroptik. Der Glanz der polierten Erzeugnisse legt eine Verwendung als Wandverkleidung, als Bodenbelag im Wohnungsbereich sowie, nach geeigneter Überprüfung der absehbaren Beanspruchung, im gewerblichen Bereich mit geringem Personenverkehr nahe.

**Rutschfest**  
 Rutschfeste Oberflächen bieten die richtige Verbindung von Ästhetik, Zuverlässigkeit und Sicherheit und eignen sich für Bodenbeläge in Außenbereichen, für öffentliche und gewerbliche Flächen sowie private Durchgangsbereiche mit spezifischen Anforderungen.

**Naturale**  
 La finitura naturale permette di cogliere l'originale essenza materica del prodotto. Resistente e versatile, questa superficie è indicata per la posa a pavimento e a parete negli spazi residenziali, commerciali e pubblici ad alto traffico.

**Soft**  
 La finitura soft, caratterizzata da una versatilità simile a quella della finitura naturale, è ideata per conferire alla materia ceramica un aspetto morbido e satinato, ed è indicata per rivestire pareti e pavimenti di ambienti residenziali e commerciali con le opportune verifiche sulle sollecitazioni e specifiche previste.

**Lappata e Molata**  
 Lappatura e Molatura sono particolari lavorazioni della superficie ceramica in grado di produrre un leggero ma continuo effetto lucido che asseconda in maniera uniforme la struttura del materiale. Tali superfici sono apprezzate come elemento di interior design dallo stile versatile, adatto sia a contesti storici sia al dialogo con architetture contemporanee. Ideali in interno, nelle realizzazioni residenziali sia a pavimento sia a rivestimento, i materiali ceramici lappati si possono impiegare anche in spazi commerciali e pubblici a traffico medio.

**Levigata**  
 Il gres porcellanato con superficie levigata assume la lucentezza di uno specchio, esaltando le colorazioni e le venature dei materiali d'ispirazione ad effetto marmo. La brillantezza dei prodotti levigati ne suggerisce l'impiego per il rivestimento delle pareti, per la creazione di pavimenti negli spazi interni in ambito residenziale e, con opportune verifiche sulle sollecitazioni previste, in ambito commerciale leggero.

**Grip**  
 La superficie Grip è il giusto connubio tra estetica, affidabilità e sicurezza ed è idonea per la realizzazione di pavimentazioni delle aree esterne, degli spazi pubblici e commerciali e dei passaggi delle aree private dove sono richiesti requisiti specifici.

**Natural**  
 El acabado natural permite captar la esencia matérica original del producto. Resistente y versátil, esta superficie es adecuada para la instalación de pisos y paredes en espacios residenciales, comerciales y públicos de alto tráfico.

**Soft**  
 El acabado soft, caracterizado por una versatilidad parecida a la del natural, es adecuado para dar al material cerámico un aspecto suave y satinado, y está indicado para revestir paredes y suelos de entornos residenciales y comerciales previas las debidas comprobaciones de los esfuerzos y las especificaciones previstos.

**Lapeada y Molida**  
 Lapeado y molida son procesos particulares de la superficie cerámica capaces de producir un efecto brillante ligero pero continuo que soporta uniformemente la estructura del material. Estas superficies son apreciadas como un elemento de diseño interior con un estilo versátil, adecuado tanto para contextos históricos como para el diálogo con la arquitectura contemporánea. Ideal para interiores, en aplicaciones residenciales tanto en suelos como en paredes, los materiales cerámicos lapeados también se pueden usar en espacios comerciales y públicos de tránsito medio.

**Alisada**  
 El gres porcelánico con una superficie lisa adquiere el brillo de un espejo, realzando los colores y las vetas de los materiales inspirados en el mármol. El brillo de los productos alisados sugiere su uso para el revestimiento de paredes, para la creación de suelos en interiores residenciales y, con las debidas comprobaciones de las tensiones esperadas, en entornos comerciales ligeros.

**Grip**  
 La superficie Grip es la combinación correcta de estética, confiabilidad y seguridad y es adecuada para la construcción de suelos en áreas al aire libre, espacios públicos y comerciales y pasajes en áreas privadas donde se requieren requisitos específicos.



## Porcelain stoneware. A safe choice

Fine porcelain stoneware is created out of a blend of top-quality raw materials, appropriately processed and fired at a temperature till 1250°C to guarantee complete vitrification. Porcelain stoneware products offer outstanding hardness, resistance, compactness, non-absorbency and frost-proofing, making them uniquely high-performing materials for use in architecture in a great variety of different contexts.

-

## Il gres porcellanato. Una scelta sicura

Il gres fine porcellanato nasce da un mix di materie prime pregiate, opportunamente lavorate e sottoposte a cottura a una temperatura fino a 1250 C° che ne garantisce la perfetta greificazione. I prodotti in gres porcellanato presentano caratteristiche di eccezionale durezza, resistenza, compattezza, inassorbenza e ingelività che li rende inimitabili, per prestazioni, nell'impiego in architettura nei più svariati ambiti di utilizzo.

### Le grès cérame. Un choix sûr

Le grès cérame fin est fabriqué à partir d'un mélange de matières premières fines, traitées de manière appropriée et cuites à une température jusqu'à 1250 °C, ce qui garantit une grésification parfaite. Les produits en grès cérame présentent des caractéristiques de dureté, de résistance, de compacité, de non-absorption et de résistance au gel exceptionnelles qui les rendent inimitables, en termes de performances, pour une utilisation en architecture dans les domaines d'utilisation les plus variés.

### Feinsteinzeug. Eine sichere Wahl

Feinsteinzeug entsteht aus einer Mischung wertvoller Rohstoffe, die entsprechend verarbeitet und bei einer Temperatur bis zu 1250 °C gebrannt werden, wodurch die perfekte Sinterung erreicht wird. Feinsteinzeug zeichnet sich durch eine ganz besondere Härte, Festigkeit, Dichte, Wasserundurchlässigkeit und Forstbeständigkeit aus, die es seinen Leistungen nach zu einem unvergleichlichen Material für die unterschiedlichsten architektonischen Verwendungsbereiche macht.

### Gres porcelánico. Una elección segura

El fino gres porcelánico proviene de una mezcla de materias primas finas, adecuadamente procesadas y sometidas a cocción a una temperatura hasta 1250 °C, lo que garantiza su perfecta crudeza. Los productos de gres porcelánico exhiben características de excepcional dureza, resistencia, compacidad, no absorción y resistencia a las heladas, lo que los hace inimitables, por sus prestaciones, en el uso en arquitectura en los más variados ámbitos.

★★★★★  
**MONOCIBEC**  
FINCIBEC GROUP

**DOES NOT BURN - NON BRUCIA**  
NE BRÛLE PAS -NIGHT BRENNBAR -NO QUEMA

**ENVIRONMENTALLY FRIENDLY - AMA L'AMBIENTE**  
RESPECTE L'ENVIRONNEMENT - UMWELTFREUNDLICH - AMA EL MEDIO AMBIENTE

**SAFE - SICURO**  
SÛR -SICHER - SEGURO

**HYGIENIC - IGIENICO**  
HYGIÉNIQUE - HYGIENISCH - HIGIÉNICO

**LONG-LASTING - DURA A LUNGO**  
LONGUE DURÉE - LANGLEBIG - LARGA DURACIÓN

**VERSATILE - VERSATILE**  
VERSATILE - VIELSEITIG - VERSÁTIL

**STRONG - RESISTENTE**  
RÉSISTANT - WIDERSTANDSFÄHIG - RESISTENTE

**STABLE - STABILE**  
STABLE - BESTÄNDIG - ESTABLE

**More information on p. 206 - Maggiori informazioni a pag. 206**

Plus d'informations à la page 206 - Mehr Informationen auf S. 206 - Más información en la página 206

## Index

The Company

Technology

Sizes

Thicknesses

Surfaces

Porcelain stoneware

Ecologycare

Certifications

Quality and Safety

Ceramic of Italy

Fincibec Group

Campus

Engineering

Pools &amp; Wellness

Facades

Raised Flooring

Technical Specifications

### ➤ Contents by collection

Archè	Geobrick
Ashley	Graphis
Azimuth	On Stage
Blade	Pietra Castello
Charisma	Pietre Naturali
Dicta	Tradition
Dolomite	Transalp
Esprit	Woodtime
Evolution	Yukon
Gamut	Major

### ➤ Contents by effect

WOOD - Legno  
MARBLE - Marmo  
STONE - Pietra  
CONCRETE - Cemento

### ➤ Color Index

Color Index Major 20mm

# Ecologycare

Monocibec has pursued an attentive corporate environmental policy for many years. The entire production cycle offers special guarantees for environmental protection. All of the products of the group are manufactured using raw materials with low environmental impact, and require limited consumption of natural resources. The electricity used is self-produced through a cogeneration system, which dramatically reduces atmospheric emissions. All wastes are reused in the production cycle. All refuse from activities unrelated to production are carefully collected, differentiated, recycled and disposed of. Every phase of product creation (raw material extraction, glaze preparation, glazing, firing, sorting and packaging) takes place with the utmost respect for man and the environment, through an analysis of the entire product life cycle. The various certifications obtained by Monocibec products show that the company prioritises having an industrial eco-sustainability model.

## Index

- The Company
- Technology
- Sizes
- Thicknesses
- Surfaces
- Porcelain stoneware
- Ecologycare**
- Certifications
- Quality and Safety
- Ceramic of Italy
- Fincibec Group
- Campus
- Engineering
- Pools & Wellness
- Facades
- Raised Flooring
- Technical Specifications

### > Contents by collection

Archè	Geobrick
Ashley	Graphis
Azimuth	On Stage
Blade	Pietra Castello
Charisma	Pietre Naturali
Dicta	Tradition
Dolomite	Transalp
Esprit	Woodtime
Evolution	Yukon
Gamut	Major

### > Contents by effect

WOOD - Legno  
 MARBLE - Marmo  
 STONE - Pietra  
 CONCRETE - Cemento

### > Color Index

Color Index Major 20mm

Monocibec persegue da anni un'attenta e continua politica di ecologia industriale. L'intero ciclo produttivo offre particolari garanzie di salvaguardia dell'ambiente. Tutti i prodotti del gruppo sono realizzati utilizzando materie prime a basso impatto ambientale e richiedono limitati consumi di risorse naturali; in particolare l'energia elettrica utilizzata è autoprodotta attraverso il sistema della cogenerazione che riduce drasticamente le emissioni in atmosfera. Tutti gli scarti di lavorazione vengono riutilizzati nel ciclo produttivo. Tutti i rifiuti derivati da attività estranee alla produzione vengono accuratamente raccolti in modo differenziato, riciclati e smaltiti. Ogni fase della realizzazione del prodotto (estrazione delle materie prime, preparazione degli smalti, smaltatura, cottura, scelta ed imballaggio) tiene in considerazione il rigoroso rispetto dell'ambiente e dell'uomo attraverso un'analisi rivolta all'intero ciclo di vita del prodotto. Le diverse certificazioni ottenute dai prodotti Monocibec testimoniano come per l'azienda sia una priorità rappresentare un modello di ecosostenibilità industriale.

Depuis des années, Monocibec mène une politique attentive et constante d'écologie industrielle. Tout le cycle de production offre des garanties particulières de protection de l'environnement. Tous les produits Monocibec sont réalisés avec des matières premières à faible impact sur l'environnement et requièrent une consommation limitée de ressources naturelles. En ce qui concerne l'énergie électrique, celle-ci est autoproduite grâce au système de cogénération réduisant considérablement les émissions dans l'atmosphère. Tous les déchets de transformation sont réutilisés dans le cycle de production. Tous les déchets dérivant d'activités autres que celles de la production sont soigneusement récupérés, triés, recyclés et mis au rebut. Chaque phase de la réalisation du produit (extraction des matières premières, préparation des émaux, émaillage, cuisson, choix et emballage) tient compte du respect rigoureux de l'environnement et de l'homme grâce à une analyse de l'ensemble du cycle de vie du produit. Les différentes certifications obtenues par les produits Monocibec témoignent à quel point il est fondamental pour la société de représenter un modèle d'éco-durabilité industrielle.

Monocibec verfolgt seit Jahren eine aufmerksame und konstante ökologische Unternehmenspolitik. Der gesamte Produktionskreislauf garantiert die Umweltverträglichkeit. Alle Produkte der Unternehmensgruppe werden aus umweltschonenden Rohstoffen hergestellt und benötigen geringe Ressourcen; vor allem wird der Strom durch Kraft-Wärme-Kopplung selbst erzeugt, wodurch Emissionen drastisch reduziert werden. Alle Bearbeitungsrückstände werden im Produktionskreislauf erneut verwendet. Abfall, der nicht aus der Produktion kommt, wird sorgfältig getrennt, recycelt und entsorgt. Umweltschutz und Arbeitssicherheit stehen bei der gesamten Herstellung im Mittelpunkt (Rohstoffgewinnung, Vorbereitung der Lacke, Lackierung, Brennen, Auswahl und Verpackung). Die diversen Zertifizierungen der Produkte von Monocibec bestätigen, dass es für das Unternehmen oberste Priorität hat, ein Modell industrieller Umweltverträglichkeit zu verfolgen.

Monocibec lleva años ajustándose a una atenta y continua política de ecología industrial. Todo el ciclo productivo ofrece garantías especiales de protección del medioambiente. Todos los productos del Grupo se realizan empleando materias primas de bajo impacto ambiental y requieren consumos limitados de recursos naturales; en particular, la energía eléctrica utilizada se produce de forma autónoma mediante el sistema de la cogeneración, que reduce de forma drástica las emisiones a la atmósfera. Todos los desechos de fabricación se reutilizan en el ciclo productivo. Se realiza la recogida selectiva de todos los residuos procedentes de actividades ajenas a la producción, con vistas a su reciclaje o eliminación. Cada fase de realización del producto (extracción de materias primas, preparación de los esmaltes, esmaltado, cocción, selección y embalaje) tiene en cuenta un respeto estricto del medioambiente y del ser humano mediante un análisis que abarca todo el ciclo de vida del producto. Las distintas certificaciones obtenidas para los productos Monocibec demuestran que para la empresa es prioritario constituir un modelo de ecosostenibilidad industrial.

# Index

The Company  
Technology  
Sizes  
Thicknesses  
Surfaces  
Porcelain stoneware  
**Ecologycare**  
Certifications  
Quality and Safety  
Ceramic of Italy  
Fincibec Group  
Campus  
Engineering  
Pools & Wellness  
Facades  
Raised Flooring  
Technical Specifications

## > Contents by collection

Archè	Geobrick
Ashley	Graphis
Azimuth	On Stage
Blade	Pietra Castello
Charisma	Pietre Naturali
Dicta	Tradition
Dolomite	Transalp
Esprit	Woodtime
Evolution	Yukon
Gamut	Major

## > Contents by effect

WOOD - Legno  
MARBLE - Marmo  
STONE - Pietra  
CONCRETE - Cemento

## > Color Index

Color Index Major 20mm



**In accordance with ISO 14021 requirements, many collections produced by Monocibec contain recycled materials, guaranteeing that architects / designers that use them obtain credits under the LEED building energy co-evaluation rating system.**

Conformément aux normes ISO 14021, de nombreuses collections produites par Monocibec contiennent des matériaux recyclés pour permettre aux architectes et aux concepteurs qui les utiliseront, d'obtenir des crédits importants dans le cadre du système d'évaluation écoénergétique des bâtiments LEED.

In Übereinstimmung mit ISO 14021 beinhalten viele Produktlinien von Monocibec recyceltes Material, wodurch Architekten/Projektleitern, die dieses verwenden, wichtige Pluspunkte bei der Bewertung für ökologisches Bauen gemäß LEED erhalten.

**In accordo con i requisiti ISO 14021, numerose collezioni prodotte da Monocibec contengono al loro interno materiale riciclato, garantendo agli architetti/progettisti che le utilizzeranno il raggiungimento di importanti crediti relativi al sistema di rating di valutazione ecoenergetica degli edifici LEED.**

De acuerdo con los requisitos de la norma ISO 14021, son numerosas las colecciones fabricadas por Monocibec que contienen material reciclado, con vistas a garantizar que los arquitectos/proyectistas que las van a utilizar puedan conseguir puntuaciones destacadas en relación con el sistema de clasificación en la valoración ecoenergética LEED de los edificios.



**Monocibec products are LEED compliant. LEED is a rating system for the environmental performance of buildings, which promotes integrated and sustainable planning for an entire building throughout its life cycle. The LEED system defines the standards that characterise the environmental impact of the building during the phases of design, construction and maintenance.**

**Monocibec is a member of the Italy Green Building Council, an association that serves for the consolidation and dissemination of the LEED rating system.**

Les produits Monocibec sont conformes au système LEED. LEED est un système de notation des performances environnementales qui encourage une conception intégrée et durable de l'ensemble du bâtiment, depuis sa construction et pour toute sa durée de vie. Le système LEED définit les critères qui caractérisent l'impact du bâtiment sur l'environnement depuis la phase du projet, jusqu'à sa construction et sa maintenance.

Monocibec est membre du Green Building Council Italia (Conseil italien du bâtiment durable), une association dont le principal objectif est de consolider et d'étendre le système d'évaluation Leed.

Monocibec-Produkte sind LEED compliant. LEED ist ein Bewertungssystem umweltverträglicher Gebäudeleistungen, das für eine integrierte und umweltgerechte Planung des gesamten Gebäudes während seines Lebenszyklus steht. Das LEED-System legt die Standards für Nachhaltigkeit bei Planung, Bau und Instandhaltung von Gebäuden fest.

Monocibec ist Mitglied des Green Building Council Italia, einer Vereinigung, deren Hauptziel die Verbreitung und Konsolidierung des LEED-Bewertungssystems ist.

I prodotti Monocibec sono LEED compliant. LEED è un sistema di rating delle performance ambientali degli edifici che promuove una progettazione integrata e sostenibile, riguardante l'intera costruzione, nel corso del suo ciclo di vita. Il sistema LEED definisce gli standard che caratterizzano l'impatto ambientale dell'edificio nella fase del progetto, durante la costruzione e nella manutenzione dello stesso.

**Monocibec è membro del Green Building Council Italia, associazione che ha fra i principali obiettivi il consolidamento e la diffusione del sistema di rating LEED.**

Los productos Monocibec cumplen con el programa de Liderazgo en Diseño Energético y Ambiental (LEED). LEED es un sistema de calificación de los resultados ambientales de los edificios que fomenta los proyectos integrados y sostenibles, de toda la construcción, durante su ciclo de vida. El programa LEED establece los estándares que caracterizan el impacto ambiental del edificio en la fase de proyecto, durante la construcción y para su mantenimiento.

Monocibec forma parte del Green Building Council Italia, una asociación que entre sus objetivos principales tiene la consolidación y la difusión del sistema de clasificación LEED.



**Voluntary environmental product declaration that provides the environmental aspects of a product as obtained through a life cycle analysis (LCA) and verified by an independent entity. Fincibec S.p.A is part of the industry media EPD study promoted by Confindustria Ceramica.**

Une déclaration environnementale de produit de type volontaire qui prévoit la communication des caractéristiques environnementales d'un produit obtenues à travers une analyse du cycle de vie (LCA) et vérifiées par un sujet indépendant. Fincibec S.p.A fait partie de l'étude DEP de niveau sectoriel voulue par Confindustria Ceramica

Eine Erklärung zur Umweltfreundlichkeit eines Produkts auf freiwilliger Basis, die die Mitteilung der Umweltaspekte eines Produkts beinhaltet, die durch eine systematische Analyse der Umweltwirkungen von Produkten während des gesamten Lebensweges (LCA) ermittelt und von einem unabhängigen Dritten bestätigt werden. Fincibec S.p.A. nimmt an der von Confindustria Ceramica initiierten EPD-Studie des Sektors teil.

**Dichiarazione ambientale di prodotto di tipo volontario, che prevede la comunicazione degli aspetti ambientali di un prodotto, ottenuti attraverso un'analisi di un ciclo di vita (LCA) e verificato da un soggetto indipendente. Fincibec S.p.A fa parte dello studio EPD media settoriale promosso da Confindustria Ceramica.**

Declaración ambiental de producto de tipo voluntario, que prevé la comunicación de los aspectos ambientales de un producto, obtenidos a través de un análisis de ciclo de vida (LCA) y comprobado por un organismo independiente. Fincibec S.p.A forma parte del estudio de EPD media de sector fomentado por Confindustria Ceramica.

# Index

The Company

Technology

Sizes

Thicknesses

Surfaces

Porcelain stoneware

Ecologycare

**Certifications**

Quality and Safety

Ceramic of Italy

Fincibec Group

Campus

Engineering

Pools & Wellness

Facades

Raised Flooring

Technical Specifications

## Contents by collection

Archè	Geobrick
Ashley	Graphis
Azimuth	On Stage
Blade	Pietra Castello
Charisma	Pietre Naturali
Dicta	Tradition
Dolomite	Transalp
Esprit	Woodtime
Evolution	Yukon
Gamut	Major

## Contents by effect

WOOD - Legno  
MARBLE - Marmo  
STONE - Pietra  
CONCRETE - Cemento

## Color Index

Color Index Major 20mm

## Quality and Safety

Monocibec is equipped with certified Safety and quality management systems that allow constant monitoring of all production process stages with an outlook to guarantee pre-set quality standards for maximum end customer satisfaction and occupational health and safety.

## Qualità e Sicurezza

Monocibec è dotata di sistemi di gestione della Qualità e della sicurezza certificati che permettono di monitorare costantemente tutte le fasi del processo produttivo nell'ottica della garanzia degli standard qualitativi prefissati per la massima soddisfazione del cliente finale e della sicurezza e salute sul lavoro.

### Qualité et Sécurité

Monocibec est équipé de systèmes de gestion de la qualité et de la sécurité certifiés qui permettent de contrôler en permanence toutes les phases du processus de production en vue de garantir les normes de qualité fixées pour une satisfaction maximale du client et la santé et la sécurité au travail.

### Qualität und Sicherheit

Monocibec verfügt über zertifizierte Qualitätsmanagement- und Sicherheitssysteme, die die Überwachung aller Produktionsphasen mit Blick auf die Garantie der festgesetzten Qualitätsstandards zur maximalen Kundenzufriedenheit sowie die Gewährleistung von Sicherheit und Gesundheit am Arbeitsplatz ermöglichen.

### Calidad y Seguridad

Monocibec consta de sistemas certificados de gestión de calidad y seguridad que le permiten monitorear constantemente todas las fases del proceso de producción con el fin de garantizar los estándares de calidad establecidos, para la máxima satisfacción del cliente final y la seguridad y salud en el trabajo.



## Index

- The Company
- Technology
- Sizes
- Thicknesses
- Surfaces
- Porcelain stoneware
- Ecologycare
- Certifications
- Quality and Safety**
- Ceramic of Italy
- Fincibec Group
- Campus
- Engineering
- Pools & Wellness
- Facades
- Raised Flooring
- Technical Specifications

### > Contents by collection

Archè	Geobrick
Ashley	Graphis
Azimuth	On Stage
Blade	Pietra Castello
Charisma	Pietre Naturali
Dicta	Tradition
Dolomite	Transalp
Esprit	Woodtime
Evolution	Yukon
Gamut	Major

### > Contents by effect

WOOD - Legno  
 MARBLE - Marmo  
 STONE - Pietra  
 CONCRETE - Cemento

### > Color Index

Color Index Major 20mm





**International Quality Standard that demonstrates the commitment of Monocibec to customer satisfaction**

Normes internationales de qualité qui démontrent l'application que met Monocibec à répondre toujours aux besoins de ses clients.

Internationale Qualitätsstandards, die das Engagement von Monocibec für die Kundenzufriedenheit demonstrieren

**Standard internazionale della Qualità che dimostra l'impegno di Monocibec verso la soddisfazione dei clienti**

Normas internacionales de Calidad que demuestran el compromiso de Monocibec con la satisfacción de los clientes



**All Monocibec products are CE certified**

Tous les produits Monocibec sont certifiés CE

Alle Produkte von Monocibec sind zertifiziert gemäß CE

**Tutti i prodotti Monocibec sono certificati CE**

Todos los productos Monocibec están certificados CE

ISO 13006  
EN 14411

**All Monocibec products are made according to the stringent international and European tile certification standards**

Tous les produits Monocibec sont réalisés conformément aux normes internationales et européennes les plus strictes en matière de certification des carrelages.

Alle Produkte von Monocibec werden gemäß der geltenden internationalen und europäischen Normen für die Zertifizierung von Fliesen gefertigt.

**Tutti i prodotti Monocibec sono realizzati secondo le esigenti norme internazionali ed europee di certificazione delle piastrelle**

Todos los productos Monocibec son realizados con arreglo a las normas europeas e internacionales más estrictas de certificación de las baldosas



**Raw materials used by Monocibec are not harmful for operators or the end user**

Les matières premières utilisées par Monocibec ne sont pas nocives pour les opérateurs et l'utilisateur final.

Die von Monocibec verwendeten Rohstoffe sind für Arbeiter und Endverbraucher unschädlich

**Le materie prime utilizzate da Monocibec non sono dannose per gli operatori e l'utilizzatore finale**

Las materias primas utilizadas por Monocibec no son nocivas para los operarios ni para los usuarios finales



**Several Monocibec products have obtained the strict French product certifications**

Différents articles Monocibec ont reçu les certifications de produit françaises rigoureuses

Verschiedene Produkte von Monocibec wurden nach den anspruchsvollen französischen Verfahren zertifiziert.

**Diversi articoli Monocibec hanno ottenuto le rigorose certificazioni di prodotto francese**

Varios artículos Monocibec han obtenido las exigentes certificaciones de producto francesas.



**Monocibec ensures compliance with the highest standards of health and safety in the workplace, and considers them requisite values. The company is constantly committed to preventing accidents in the workplace and protecting the health of its employees.**

Monocibec garantit le respect des critères de sécurité et de santé les plus élevés et les considère comme des valeurs incontournables. La société travaille constamment à la prévention des incidents et à la sauvegarde de la santé de son personnel.

Monocibec gewährleistet die Einhaltung strengster Kriterien zur Sicherheit und des Gesundheitsschutzes am Arbeitsplatz, was für das Unternehmen unabdingbare Werte sind. Monocibec bemüht sich kontinuierlich darum, Vorsorgemaßnahmen gegen Arbeitsunfälle zu treffen und die Gesundheit der Arbeitnehmer zu schützen.

**Monocibec assicura il rispetto dei più elevati criteri di sicurezza e salute sul lavoro, ritenendoli valori imprescindibili. L'azienda si impegna costantemente per prevenire gli incidenti sul lavoro e per tutelare la salute dei suoi addetti.**

Monocibec asegura el cumplimiento de los más estrictos criterios de seguridad y salud laboral, ya que los considera valores imprescindibles. La empresa actúa continuamente para prevenir los accidentes laborales y para proteger la salud de sus empleados.

# Index

- The Company
- Technology
- Sizes
- Thicknesses
- Surfaces
- Porcelain stoneware
- Ecologycare
- Certifications
- Quality and Safety**
- Ceramic of Italy
- Fincibec Group
- Campus
- Engineering
- Pools & Wellness
- Facades
- Raised Flooring
- Technical Specifications

## ➤ Contents by collection

- |           |                 |
|-----------|-----------------|
| Archè     | Geobrick        |
| Ashley    | Graphis         |
| Azimuth   | On Stage        |
| Blade     | Pietra Castello |
| Charisma  | Pietre Naturali |
| Dicta     | Tradition       |
| Dolomite  | Transalp        |
| Esprit    | Woodtime        |
| Evolution | Yukon           |
| Gamut     | Major           |

## ➤ Contents by effect

- WOOD - Legno
- MARBLE - Marmo
- STONE - Pietra
- CONCRETE - Cemento

## ➤ Color Index

Color Index Major 20mm



Ces logos témoignent d'une indication géographique d'origine précise et d'une façon de faire des affaires liées aux plus hautes valeurs éthiques et culturelles. Les produits fabriqués par MONOCIBEC sont entièrement conçus, étudiés et fabriqués en Italie. Chaque collection est conçue et testée dans les laboratoires de recherche et de développement du groupe et toutes les phases de production ultérieures sont réalisées exclusivement dans des usines italiennes utilisant la technologie italienne. MONOCIBEC veut identifier une philosophie de travail qui, dans le plus grand respect de l'environnement et de l'homme, conduit à la réalisation de matériaux selon les plus hauts standards de performance et d'esthétique par l'optimisation de toutes les ressources utilisées. MONOCIBEC adhère au code d'éthique du Made in Italy promu par Confindustria Ceramica avec lequel toutes les entreprises adhérentes s'engagent à une transparence maximale en ce qui concerne l'origine des produits en y apposant la marque.

Die Logos stehen für eine genaue geografische Herkunftsangabe und für eine Art der Unternehmensführung, die hohe ethische und kulturelle Werte ansetzt. Alle Erzeugnisse von MONOCIBEC werden ausschließlich in Italien konzipiert und hergestellt. Jede Kollektion wird in den Forschungs- und Entwicklungslabors der Gruppe entworfen und geprüft und alle anschließenden Produktionsphasen erfolgen ausnahmslos in italienischen Werken und mit italienischer Technologie. MONOCIBEC verfolgt eine Arbeitsphilosophie, die unter größter Achtung der Umwelt und des Menschen durch Optimierung aller eingesetzten Ressourcen auf die Herstellung von Materialien mit höchsten ästhetischen Ansprüchen und Leistungsstandards abzielt. MONOCIBEC befürwortet den Ethik-Kodex der Confindustria Ceramica zum Made in Italy, mit dem alle ihn befürwortenden Unternehmen sich zu größter Transparenz hinsichtlich der Produktherkunft verpflichten und das entsprechende Markenzeichen anbringen.

Estos logotipos dan testimonio de una indicación geográfica precisa del origen y una forma de hacer negocios vinculados a los más altos valores éticos y culturales. Los productos fabricados por MONOCIBEC están completamente concebidos, estudiados y fabricados en Italia. Cada colección está diseñada y verificada en los laboratorios de investigación y desarrollo del grupo y todas las fases de producción posteriores se llevan a cabo exclusivamente en fábricas italianas con tecnología italiana. MONOCIBEC quiere identificar una filosofía de trabajo que, con el máximo respeto por el medio ambiente y el hombre, lleve a la realización de materiales según los más altos estándares de rendimiento y estética a través de la optimización de todos los recursos utilizados. MONOCIBEC respeta el código ético sobre el "Made in Italy" promovido por Confindustria Ceramica, con el que todas las empresas miembros se comprometen a la máxima transparencia en cuanto al origen de sus productos mediante la colocación de la marca.

★★★★★  
MONOCIBEC®  
100%  
MADE IN ITALY

“  
Ceramics of Italy  
”

★★★★★  
MONOCIBEC®  
FINCIBEC GROUP

## 100% Ceramic of Italy

These logos demonstrate a precise geographical location of origin and a way of running a business enterprise with the highest ethical and cultural values. The products made by Monocibec are wholly designed, developed and manufactured in Italy.

Each collection is designed and checked in the group's three R&D laboratories and all the subsequent production stages are carried out exclusively in Italian facilities with Italian technology.

By using the above-mentioned logos, the aim of Monocibec is to identify a work philosophy which, with the utmost respect for the environment and man, leads to the production of materials adhering to the highest standards of performance and aesthetics through the best use of all the resources available.

Monocibec adheres to the 'Made in Italy' code of ethics promoted by the Italian industrial ceramics association, 'Confindustria Ceramica', and is committed to full transparency on the origin of its products market with the brand.

Questi loghi testimoniano una precisa indicazione geografica di provenienza ed un modo di fare impresa legato ai più alti valori etici e culturali. I prodotti realizzati da MONOCIBEC sono completamente ideati, studiati e fabbricati in Italia.

Ogni collezione viene progettata e verificata nei laboratori di ricerca e sviluppo del gruppo e tutte le successive fasi produttive sono realizzate esclusivamente all'interno di stabilimenti italiani con tecnologia italiana. MONOCIBEC vuole identificare una filosofia di lavoro che, nel massimo rispetto dell'ambiente e dell'uomo, porti alla realizzazione di materiali secondo i più elevati standards prestazionali ed estetici attraverso l'ottimizzazione di tutte le risorse impiegate. MONOCIBEC aderisce al codice etico sul Made in Italy promosso da Confindustria Ceramica con il quale tutte le aziende aderenti si impegnano alla massima trasparenza riguardo l'origine dei prodotti apponendovi il marchio.

The Company
Technology
Sizes
Thicknesses
Surfaces
Porcelain stoneware
Ecologycare
Certifications
Quality and Safety
<b>Ceramic of Italy</b>
Fincibec Group
Campus
Engineering
Pools & Wellness
Facades
Raised Flooring
Technical Specifications

### ➤ Contents by collection

Archè	Geobrick
Ashley	Graphis
Azimuth	On Stage
Blade	Pietra Castello
Charisma	Pietre Naturali
Dicta	Tradition
Dolomite	Transalp
Esprit	Woodtime
Evolution	Yukon
Gamut	Major

### ➤ Contents by effect

WOOD - Legno
MARBLE - Marmo
STONE - Pietra
CONCRETE - Cemento

### ➤ Color Index

Color Index Major 20mm
------------------------



Fincibec Group est une réalité industrielle leader au niveau mondial dans la production de carrelages en céramique pour sols et murs. Sa mission est d'être une référence pour les consommateurs les plus exigeants, en offrant aux concepteurs, architectes et décorateurs d'intérieur la possibilité d'interpréter, de façon la plus efficace possible, les tendances design contemporaines.

Réaliser un produit à l'esthétique avancée et aux prestations techniques supérieures représente le défi que le GROUPE FINCIBEC relève chaque jour avec ses collaborateurs, qui sont plus de 500.

Le parcours de développement que le GROUPE FINCIBEC a entrepris est guidé par une passion constante pour l'innovation et la recherche, qui a marqué toute l'histoire de l'entreprise et a apporté une contribution importante à l'évolution du carrelage en céramique au niveau italien et mondial.

Fincibec Group ist ein weltbekanntes Industrieunternehmen, führend in der Herstellung von Keramikfliesen für Fußböden und zur Wandverkleidung. Das Unternehmen ist ein Bezugspunkt für die anspruchsvollsten Verbraucher und bietet Designern, Architekten und Innenarchitekten die Möglichkeit, auf die effektivste Art und Weise Zugriff auf die neuesten Trends im modernem Design zu erlangen.

Ein ästhetisches und qualitativ hochwertiges Produkt anzufertigen stellt die tägliche Herausforderung für das Unternehmen FINCIBEC GROUP, mit seinen über 500 Mitarbeitern, dar. Auf ihrem Weg, welchen die Firma FINCIBEC GROUP eingeschlagen hat, begleitet sie die Leidenschaft für das Innovative und die Suche nach Neuerungen; diese Parameter haben die Entwicklung des Unternehmens geprägt und einen wichtigen Beitrag zur Evolution italienischer und internationaler Keramik geleistet.

Fincibec Group es una realidad industrial líder mundial en la producción de revestimientos cerámicos para suelos y paredes. Su misión es la de constituir un punto de referencia para los consumidores más exigentes, ofreciendo a proyectistas, arquitectos y diseñadores de interiores la posibilidad de interpretar, de la forma más eficaz, las tendencias del diseño contemporáneo.

Realizar un producto estéticamente avanzado y con las mejores prestaciones técnicas es el desafío que el GRUPO FINCIBEC aborda a diario junto con sus más de 500 colaboradores. Los pasos por el camino del crecimiento del GRUPO FINCIBEC están guiados por su continua pasión por la innovación y la investigación, pasión que ha marcado toda su historia empresarial y que ha contribuido de manera destacada a la evolución del producto cerámico tanto italiano como mundial.

## Fincibec Group

Fincibec Group is a world leader in the ceramic wall and floor tile industrial production sector.

The mission of Fincibec Group is to represent a reference point for the most demanding consumers, offering designers, architects and interior designers the possibility to interpret contemporary design trends in the most efficient way.

Creating refined and technically high performing products is the daily challenge that FINCIBEC GROUP faces, together with more than 500 collaborators.

The growth path that FINCIBEC GROUP has taken is guided by the same continual passion for innovation and research that has marked the company's history and has made an important contribution to the evolution of the ceramic product in Italy and worldwide.

Fincibec Group è una realtà industriale leader a livello mondiale nella produzione di rivestimenti ceramici per pavimenti e pareti. La sua mission è quella di rappresentare un punto di riferimento per i consumatori più esigenti, offrendo a progettisti, architetti ed interior designer la possibilità di interpretare, nel modo più efficace, le tendenze del design contemporaneo. Realizzare un prodotto esteticamente evoluto e dalle prestazioni tecniche superiori rappresenta la sfida che ogni giorno il GRUPPO FINCIBEC affronta assieme ai suoi oltre 500 collaboratori.

Il percorso di crescita che il GRUPPO FINCIBEC persegue è guidato da quella continua passione per l'innovazione e la ricerca che ha segnato tutta la sua storia aziendale e che ha dato un importante contributo all'evoluzione del prodotto ceramico italiano e mondiale.

- The Company
- Technology
- Sizes
- Thicknesses
- Surfaces
- Porcelain stoneware
- Ecologycare
- Certifications
- Quality and Safety
- Ceramic of Italy
- Fincibec Group**
- Campus
- Engineering
- Pools & Wellness
- Facades
- Raised Flooring
- Technical Specifications

### > Contents by collection

Archè	Geobrick
Ashley	Graphis
Azimuth	On Stage
Blade	Pietra Castello
Charisma	Pietre Naturali
Dicta	Tradition
Dolomite	Transalp
Esprit	Woodtime
Evolution	Yukon
Gamut	Major

### > Contents by effect

WOOD - Legno  
 MARBLE - Marmo  
 STONE - Pietra  
 CONCRETE - Cemento

### > Color Index

Color Index Major 20mm

The Company  
 Technology  
 Sizes  
 Thicknesses  
 Surfaces  
 Porcelain stoneware  
 Ecologycare  
 Certifications  
 Quality and Safety  
 Ceramic of Italy  
 Fincibec Group  
**Campus**  
 Engineering  
 Pools & Wellness  
 Facades  
 Raised Flooring  
 Technical Specifications

## ➤ Contents by collection

Archè	Geobrick
Ashley	Graphis
Azimuth	On Stage
Blade	Pietra Castello
Charisma	Pietre Naturali
Dicta	Tradition
Dolomite	Transalp
Esprit	Woodtime
Evolution	Yukon
Gamut	Major

## ➤ Contents by effect

WOOD - Legno  
 MARBLE - Marmo  
 STONE - Pietra  
 CONCRETE - Cemento

## ➤ Color Index

Color Index Major 20mm



## Campus

watch the  
photos-video



### FINCIBEC CAMPUS

A space dedicated to the projects of the future and a dynamic operational tool, equipped to meet the needs of all professionals in the sector, such as planners, architects and interior designers, as well as those of salespeople and installers. Fincibec Group has completely renovated and expanded the structure of its Campus, which houses a large showroom, with boxes furnished to showcase the products of all Group companies, and areas dedicated to training courses and business meetings. Fincibec Campus is in Sassuolo, in the historical site of Via Verrazzano, close to the centre of the Emilian town and not far from all Fincibec production plants. A strategic location to plunge into the company reality and discover it in detail through dedicated visits, scheduled by appointment. With customers and sales points spread across all continents, there was also a need for a hyper-connected showroom to complement traditional in-person visits. The Campus showroom is equipped with state-of-the-art technology and equipment, including high-resolution cameras and microphones, large-screen TVs and LED walls, making on-demand virtual tours, direct connections, presentations and meetings possible at any time. The Campus has two large conference rooms for training and refresher events, and areas equipped for practical exercises. The increasingly wide-ranging and specific applications of ceramic materials make training events dedicated to installation, processing, handling and transformation of porcelain stoneware, designed for architecture and building professionals, a must. The showroom and training spaces of Fincibec Campus allow a direct experience of the products, in keeping with the spirit that has animated this place since its creation, where visitors actively participate in the creative process of the collections, sharing ideas and proposals with the aim of developing new products and functional solutions.

### FINCIBEC CAMPUS

Uno spazio dedicato ai progetti del futuro e uno strumento operativo dinamico, attrezzato per rispondere alle esigenze di tutti i professionisti del settore, progettisti, architetti e interior designer, oltre a quelle di venditori e posatori. Fincibec Group ha completamente rinnovato e ampliato la struttura del proprio Campus che ospita una grande sala mostra, con box arredati per valorizzare la produzione di tutte le aziende del Gruppo, e aree dedicate a corsi di formazione e meeting commerciali. Fincibec Campus si trova a Sassuolo, nello storico sito di Via Verrazzano, a ridosso del centro della cittadina emiliana e a breve distanza da tutti gli stabilimenti produttivi Fincibec. Una location strategica per immergersi nella realtà aziendale e scoprirla nel dettaglio attraverso visite dedicate, organizzate su appuntamento. Con una clientela e una presenza commerciale distribuita in tutti i continenti è emersa inoltre l'esigenza di una showroom iperconnessa, in grado di integrare le tradizionali visite in presenza. La sala mostra del Campus dispone di una dotazione tecnologica e impiantistica all'avanguardia, composta da telecamere e microfoni ad alta risoluzione, tv maxischermo e ledwall, che rende possibili visite virtuali on-demand, collegamenti diretti, presentazioni e meeting in qualsiasi momento. All'interno del Campus si trovano due grandi sale convegni per eventi di formazione e aggiornamento, ed aree attrezzate per svolgere esercitazioni pratiche. Le applicazioni sempre più ampie e specifiche dei materiali ceramici rendono indispensabili gli eventi formativi dedicati alla posa, alla lavorazione, alla movimentazione e alla trasformazione del gres porcellanato, studiati per i professionisti dell'architettura e dell'edilizia.

La sala mostra e gli spazi formativi del Fincibec Campus consentono un'esperienza diretta dei prodotti, nel rispetto dello spirito che anima questo luogo fin dalla sua creazione, dove i frequentatori partecipano attivamente al processo creativo delle collezioni, condividono idee e proposte con l'obiettivo di mettere a punto nuovi prodotti e soluzioni funzionali.

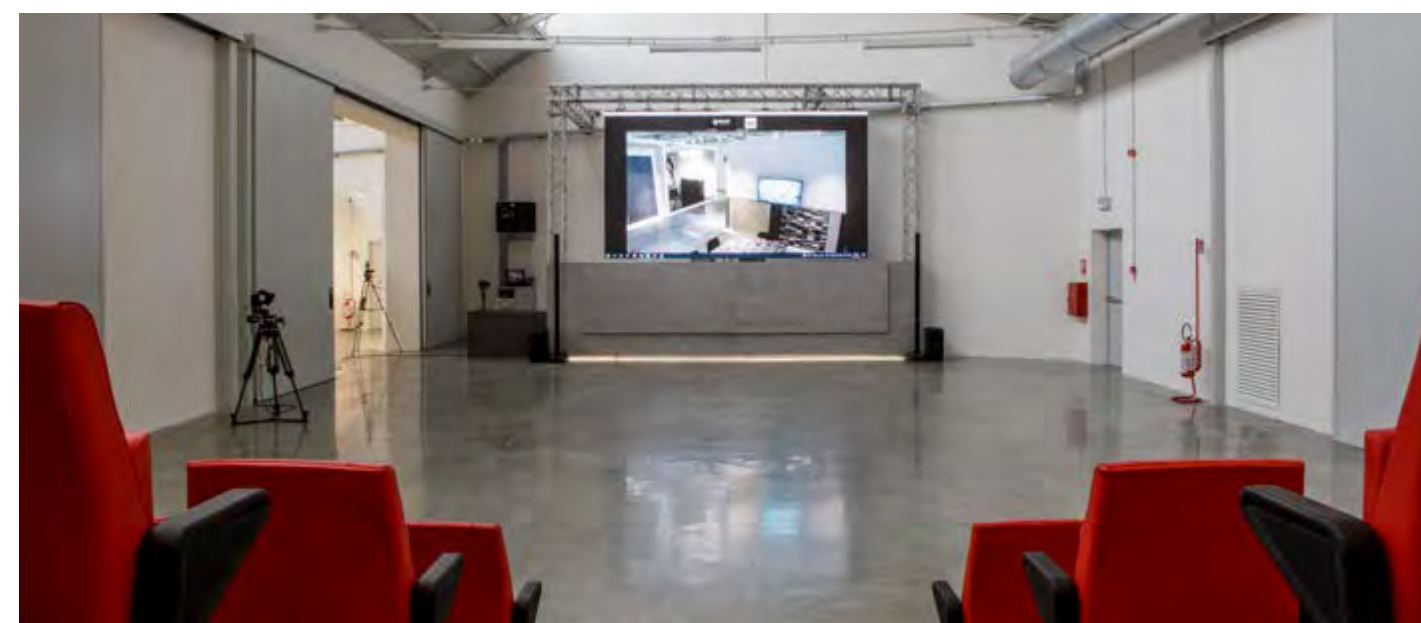

★★★★★  
**MONOCIBEC**  
 FINCIBEC GROUP

The Company  
Technology  
Sizes  
Thicknesses  
Surfaces  
Porcelain stoneware  
Ecologycare  
Certifications  
Quality and Safety  
Ceramic of Italy  
Fincibec Group  
**Campus**  
Engineering  
Pools & Wellness  
Facades  
Raised Flooring  
Technical Specifications

## ➤ Contents by collection

Archè	Geobrick
Ashley	Graphis
Azimuth	On Stage
Blade	Pietra Castello
Charisma	Pietre Naturali
Dicta	Tradition
Dolomite	Transalp
Esprit	Woodtime
Evolution	Yukon
Gamut	Major

## ➤ Contents by effect

WOOD - Legno  
MARBLE - Marmo  
STONE - Pietra  
CONCRETE - Cemento

## ➤ Color Index

Color Index Major 20mm



### FINCIBEC CAMPUS

Un espace dédié aux projets du futur et un outil opérationnel dynamique et complet capable de répondre aux exigences de tous les professionnels du secteur, qu'ils soient concepteurs, architectes ou designers d'intérieur, sans oublier les vendeurs et les poseurs. Fincibec Group a entièrement renouvelé et étendu la structure de son Campus, qui accueille une grande salle d'exposition, avec des espaces décorés pour mettre en valeur la production de toutes les entreprises du Groupe et des espaces dédiés aux formations et réunions commerciales.

Fincibec Campus se trouve à Sassuolo, dans le site historique de Via Verrazzano, à proximité du centre de la petite ville d'Émilie-Romagne et non loin de tous les établissements de production de Fincibec. Un emplacement stratégique pour s'immerger dans la réalité de l'entreprise et la découvrir dans le détail avec des visites dédiées, organisées sur rendez-vous. Notre clientèle et notre présence commerciale réparties sur tous les continents ont fait naître le besoin de créer un showroom hyperconnecté, capable d'intégrer les visites traditionnelles sur site. La salle d'exposition du Campus dispose d'équipements technologiques et d'installations d'avant-garde, avec des caméras et des micros haute résolution, une télévision grand écran et ledwall, qui permettent des visites virtuelles à la demande, des connexions directes, des présentations et des réunions à tout moment.

Le campus inclut également deux grandes salles de conférence pour des formations et des sessions de mise à niveau ainsi que des espaces équipés pour des exercices pratiques. Les applications de plus en plus vastes et spécifiques des matériaux céramiques rendent indispensables les formations dédiées à la pose, à l'usinage, à la manipulation et à la transformation du grès cérame, et créées pour les professionnels de l'architecture et du bâtiment.

La salle d'exposition et les espaces de formation du Fincibec Campus offrent une expérience directe des produits, dans le respect de l'esprit qui anime ce lieu depuis sa création, où les visiteurs participent activement au processus de création des collections en partageant les idées et les propositions dans le but de créer des produits et des solutions fonctionnels.

### FINCIBEC CAMPUS

Ein den Projekten der Zukunft gewidmeter Raum und ein dynamisches Arbeitsinstrument, das auf die Bedürfnisse aller Fachleute des Sektors, der Planer, Architekten und Innenarchitekten sowie der Verkäufer und Installateure ausgerichtet ist. Fincibec Group hat ihren Campus komplett renoviert und erweitert: Eine große Ausstellungshalle mit Logen, in denen die Produktion aller Unternehmen der Gruppe präsentiert wird, sowie Bereiche für Schulungen und Geschäftstreffen.

Den emilianischen Fincibec Campus finden Sie in Sassuolo, in der historischen Via Verrazzano, in der Nähe der Altstadt und nicht weit von allen Fincibec-Produktionsstätten entfernt. Eine strategische Location, um das Unternehmen hautnah kennen zu lernen. Buchen Sie Ihren Besuchstermin, um alles über Fincibec in Erfahrung zu bringen. Da unsere Kunden und Geschäftsstellen über alle Kontinente verteilt sind, bestand der Bedarf an einem hypervernetzten Ausstellungsraum, der die traditionellen Besuche vor Ort ergänzt. Die Ausstellung auf dem Campus verfügt über modernste Technologie und Ausrüstung, darunter hochauflösende Kameras und Mikrofone, Großbildfernseher und LED-Wände, die jederzeit virtuelle Rundgänge, Direktverbindungen, Präsentationen und Besprechungen auf Abruf ermöglichen.

Im Campus finden wir auch zwei große Konferenzräume für Aus- und Weiterbildungsveranstaltungen sowie Räume für praktische Übungen. Durch immer vielfältigere und spezifischere Anwendungen von keramischen Werkstoffen wird die Weiterbildung für Fachleute aus dem Bereich Architektur und Bauwesen unverzichtbar, die sich mit der Verlegung, Verarbeitung, Handhabung und Umwandlung von Feinsteinzeug befassen.

Die Ausstellung und die Schulungsbereiche auf dem Fincibec-Campus ermöglichen einen direkten Kontakt mit den Produkten, ganz im Sinne des Stils, der diesen Ort seit seiner Gründung beseelt. Die Besucher nehmen aktiv am kreativen Prozess der Kollektionen teil und tauschen Ideen und Vorschläge aus, um neue Produkte und funktionelle Lösungen zu entwickeln.

### FINCIBEC CAMPUS

Un espacio destinado a los proyectos del futuro y una herramienta operativa dinámica, equipada para cubrir las necesidades de todos los profesionales del sector, constructores, arquitectos e interioristas, así como las de vendedores e instaladores. Fincibec Group ha renovado y ampliado por completo la estructura de su Campus, que alberga un gran showroom, con espacios amueblados para potenciar la producción de todas las empresas del Grupo, y zonas dedicadas a cursos de formación y reuniones comerciales.

Fincibec Campus está ubicado en Sassuolo, en el histórico punto de Via Verrazzano, cerca del centro de la ciudad italiana y a poca distancia de todas las plantas de producción de Fincibec. Una ubicación estratégica para sumergirse en la realidad corporativa y descubrirla a fondo mediante visitas personalizadas para las que hay que pedir cita previa. Con una clientela y una presencia comercial en todos los continentes, surge también la necesidad de un showroom hiperconectado, capaz de integrar las tradicionales visitas presenciales. El showroom del Campus cuenta con un equipamiento tecnológico y constructivo de última generación, compuesto por cámaras y micrófonos de alta resolución y pantalla grande de televisión mural, que posibilita visitas virtuales bajo demanda, conexiones directas, presentaciones y reuniones en cualquier momento.

Dentro del Campus también hay dos grandes salas de conferencias para cursos de formación y actualización, y áreas habilitadas para la realización de ejercicios prácticos. Las aplicaciones cada vez más amplias y específicas de los materiales cerámicos hacen que resulte imprescindible ofrecer cursos de formación dedicados a la instalación, elaboración, manipulación y transformación del gres porcelánico, destinados a los profesionales de la arquitectura y la construcción.

El showroom y los espacios formativos del Campus Fincibec permiten experimentar de forma directa los productos, respetando el espíritu que caracteriza este lugar desde su creación, donde los visitantes participan activamente en el proceso creativo de las colecciones y comparten ideas y propuestas con el objetivo de desarrollar nuevos productos y soluciones funcionales.



Fine porcelain stoneware - Gres fine porcellanato  
Grès cérame fin - Feinsteinzeug - Gres fine porcelánico

## WOOD EFFECT - EFFETTO LEGNO

effet bois - Holz-Effekt - efecto madera

pag. 42 Ashley  
pag. 50 Woodtime  
pag. 56 Yukon

# Index

The Company  
Technology  
Sizes  
Thicknesses  
Surfaces  
Porcelain stoneware  
Ecologycare  
Certifications  
Quality and Safety  
Ceramic of Italy  
Fincibec Group  
Campus  
Engineering  
Pools & Wellness  
Facades  
Raised Flooring  
Technical Specifications

### > Contents by collection

Archè	Geobrick
Ashley	Graphis
Azimuth	On Stage
Blade	Pietra Castello
Charisma	Pietre Naturali
Dicta	Tradition
Dolomite	Transalp
Esprit	Woodtime
Evolution	Yukon
Gamut	Major

### > Contents by effect

WOOD - Legno

MARBLE - Marmo  
STONE - Pietra  
CONCRETE - Cemento

### > Color Index

Color Index Major 20mm

# Ashley

Fine porcelain stoneware - Gres fine porcellanato  
Grès cérame fin - Feinsteinzeug - Gres fine porcelánico

download catalogue



watch the video



Colours - Colori  
Couleurs - Farben - Colores

Larix

Nature

Nest

Chestnut

Oak

Caramel

Sizes - Formati  
Formats - Formaten - Formatos

30x120 cm  
20x120 cm  
23x100 cm

Thicknesses - Spessori  
Epaisseurs - Dicken - Espesores

9 mm

Surfaces - Superfici  
Surfaces - Oberflächen - Superficies

Natural - Naturale  
Naturelle - Natur - Natural

Grip

Edges - Bordi  
Bordes - Kanten - Bordes

Natural - Naturale  
Naturel - Natur - Natural

Rectified - Rettificato  
Rectifié - Rektifiziert - Rectificado

ISO 13006 Bla - EN 14411/G  
Fully-resistant flooring  
Pavimenti a resistenza totale  
Sols à résistance totale - Absolut widerständige  
Fußböden - Pavimentos de resistencia total



**c5** Floor tiles recommended for heavy uses.  
Piastrille da pavimento consigliate per calpestio intenso.  
Carreaux de sol recommandés pour un trafic piétonnier intense.  
Bodenfliesen, empfohlen für intensive Beanspruchung.  
Baldosas de suelo recomendadas para tránsito intenso.

**v2** Light variation - Lieve variazione  
Variation légère  
Gerinde Farbunterschied  
Variación escasa

wood effect - effetto legno - effet bois - holz-effekt - efecto madera

## Index

The Company  
Technology  
Sizes  
Thicknesses  
Surfaces  
Porcelain stoneware  
Ecologycare  
Certifications  
Quality and Safety  
Ceramic of Italy  
Fincibec Group  
Campus  
Engineering  
Pools & Wellness  
Facades  
Raised Flooring  
Technical Specifications

### > Contents by collection

Archè	Geobrick
<b>Ashley</b>	Graphis
Azimuth	On Stage
Blade	Pietra Castello
Charisma	Pietre Naturali
Dicta	Tradition
Dolomite	Transalp
Esprit	Woodtime
Evolution	Yukon
Gamut	Major

### > Contents by effect

WOOD - Legno  
MARBLE - Marmo  
STONE - Pietra  
CONCRETE - Cemento

### > Color Index

Color Index Major 20mm

## Larix

## Nature

## Nest

## Oak

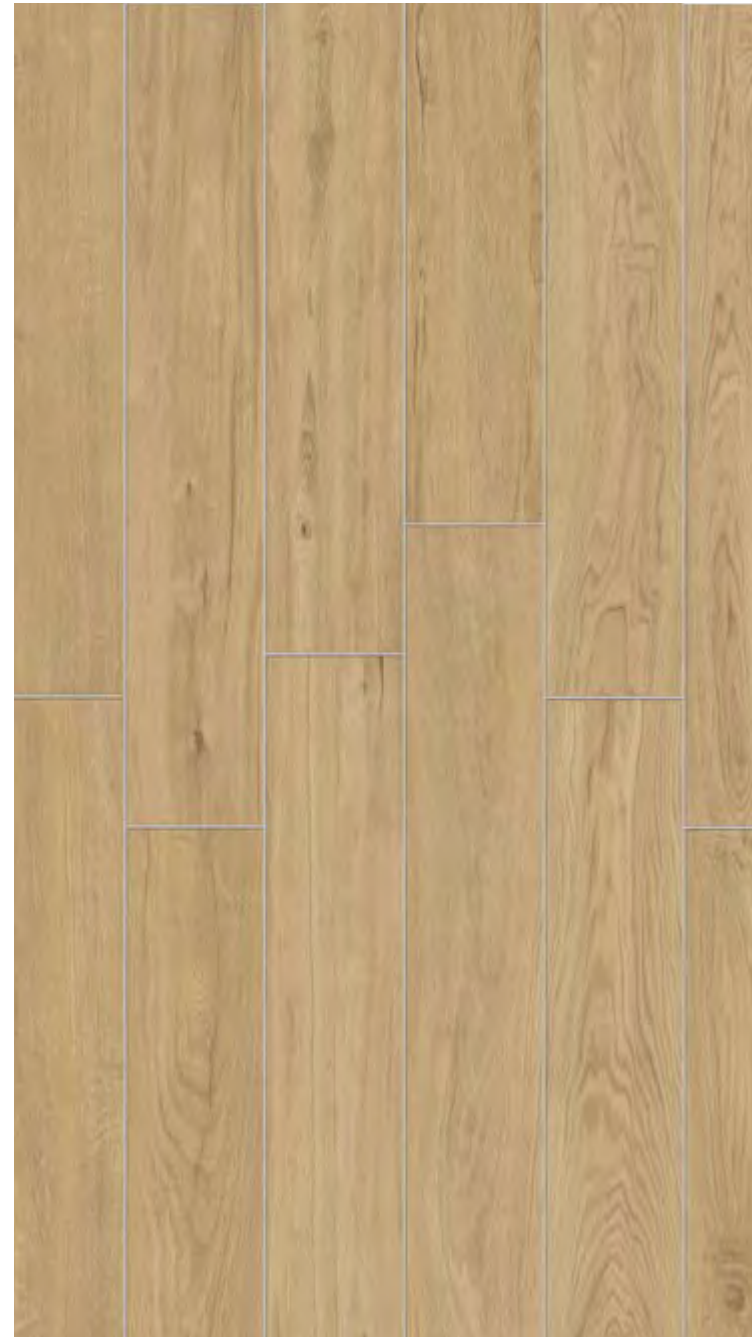

<b>SUPERFICIE NATURALE / BORDO NATURALE</b>	<b>R10</b>
23x100 - 9"x40"	9   128963   59

<b>SUPERFICIE NATURALE / BORDO NATURALE</b>	<b>R10</b>
23x100 - 9"x40"	9   128964   59

<b>SUPERFICIE NATURALE / BORDO NATURALE</b>	<b>R10</b>
23x100 - 9"x40"	9   128965   59

<b>SUPERFICIE NATURALE / BORDO RETTIFICATO</b>	<b>R10</b>
30x120 - 12"x47"	9   128415   87
20x120 - 8"x47"	9   128422   87

<b>SUPERFICIE NATURALE / BORDO RETTIFICATO</b>	<b>R10</b>
30x120 - 12"x47"	9   128410   87
20x120 - 8"x47"	9   128416   87

<b>SUPERFICIE NATURALE / BORDO RETTIFICATO</b>	<b>R10</b>
30x120 - 12"x47"	9   128413   87
20x120 - 8"x47"	9   128419   87

<b>SUPERFICIE NATURALE / BORDO RETTIFICATO</b>	<b>R10</b>
30x120 - 12"x47"	9   128414   87
20x120 - 8"x47"	9   128420   87

<b>SUPERFICIE GRIP / BORDO NATURALE</b>	<b>A+B+C R11</b>
23x100 - 9"x40"	9   130107   59

<b>SUPERFICIE GRIP / BORDO NATURALE</b>	<b>A+B+C R11</b>
23x100 - 9"x40"	9   130105   59

<b>SUPERFICIE GRIP / BORDO NATURALE</b>	<b>A+B+C R11</b>
23x100 - 9"x40"	9   130106   59

<b>SUPERFICIE GRIP / BORDO RETTIFICATO</b>	<b>A+B+C R11</b>
20x120 - 8"x47"	9   129040   87

<b>SUPERFICIE GRIP / BORDO RETTIFICATO</b>	<b>A+B+C R11</b>
20x120 - 8"x47"	9   129042   87

<b>SUPERFICIE GRIP / BORDO RETTIFICATO</b>	<b>A+B+C R11</b>
20x120 - 8"x47"	9   129043   87

# Index

- The Company
- Technology
- Sizes
- Thicknesses
- Surfaces
- Porcelain stoneware
- Ecologycare
- Certifications
- Quality and Safety
- Ceramic of Italy
- Fincibec Group
- Campus
- Engineering
- Pools & Wellness
- Facades
- Raised Flooring
- Technical Specifications

## > Contents by collection

- |               |                 |
|---------------|-----------------|
| Archè         | Geobrick        |
| <b>Ashley</b> | Graphis         |
| Azimuth       | On Stage        |
| Blade         | Pietra Castello |
| Charisma      | Pietre Naturali |
| Dicta         | Tradition       |
| Dolomite      | Transalp        |
| Esprit        | Woodtime        |
| Evolution     | Yukon           |
| Gamut         | Major           |

## > Contents by effect

- WOOD - Legno
- MARBLE - Marmo
- STONE - Pietra
- CONCRETE - Cemento

## > Color Index

Color Index Major 20mm



## Chestnut

## Caramel



SUPERFICIE NATURALE / BORDO RETTIFICATO		R10	
30x120 - 12"x47"	9	128412	87
20x120 - 8"x47"	9	128418	87



SUPERFICIE NATURALE / BORDO RETTIFICATO		R10	
30x120 - 12"x47"	9	135043	87
20x120 - 8"x47"	9	135042	87

## Stream

## Creative



SUPERFICIE NATURALE / BORDO NATURALE		R10	
* 23x100 - 9"x40"	9	130104	103

SUPERFICIE NATURALE / BORDO RETTIFICATO		R10	
* 20x120 - 8"x47"	9	128585	143



SUPERFICIE NATURALE / BORDO RETTIFICATO		R10	
* 120x120 - 47"x47"	9	128719	163

\*Decors version with multiple subjects, packaged randomly (Matchable with all colours)

Versione decoro con più soggetti, confezionati random (Abbinabili a tutti i colori)

Version décoration avec plusieurs motifs, emballés de manière aléatoire (pouvant être assortis à toutes les couleurs)

Dekorierter Ausführung mit mehreren Darstellungen, zufällige Zusammenstellung (kann mit allen Farben kombiniert werden)

Versión decoración con varios temas, empaquetados de modo aleatorio (se puede combinar con todos los colores)

▲ cm 120x120 split pallet surcharge 40 € each - lightened stand containing 95 €  
cm 120x120 addebito frazione di paletta 40 € - cavalla alleggerita 95 €  
cm 120x120 surtaxe contremarque 40 € - chevalet allégé 95 €  
cm 120x120 Aufpreis Teilpalette 40 € - leichter Ständer 95 €  
cm 120x120 recargo fracción de paleta 40 € - soporte ligero 95 €

# Index

- The Company
- Technology
- Sizes
- Thicknesses
- Surfaces
- Porcelain stoneware
- Ecologycare
- Certifications
- Quality and Safety
- Ceramic of Italy
- Fincibec Group
- Campus
- Engineering
- Pools & Wellness
- Facades
- Raised Flooring
- Technical Specifications

## Contents by collection

- |               |                 |
|---------------|-----------------|
| Archè         | Geobrick        |
| <b>Ashley</b> | Graphis         |
| Azimuth       | On Stage        |
| Blade         | Pietra Castello |
| Charisma      | Pietre Naturali |
| Dicta         | Tradition       |
| Dolomite      | Transalp        |
| Esprit        | Woodtime        |
| Evolution     | Yukon           |
| Gamut         | Major           |

## Contents by effect

- WOOD - Legno
- MARBLE - Marmo
- STONE - Pietra
- CONCRETE - Cemento

## Color Index

Color Index Major 20mm

# Ashley

Fine porcelain stoneware - Gres fine porcellanato  
Grès cérame fin - Feinsteinzeug - Gres fine porcelánico

Mosaics - Mosaici - Mosaïques - Mosaik - Mosaicos



SUPERFICIE NATURALE	
MOSAICO SU RETE 29x29 - 11"x11"	
SWEET JADE	9 130188 ● 33
SWEET ORIGIN	9 130189 ● 33

SUPERFICIE NATURALE		A+B+C
MOSAICO 2,5x2,5 - 1"x1" SU FOGLIO 30x30 - 12"x12"		
LARIX	9 130190	● 297
OAK	9 130194	● 297
NATURE	9 130191	● 297
CARAMEL	9 135057	● 297
CHESTNUT	9 130193	● 297
NEST	9 130192	● 297

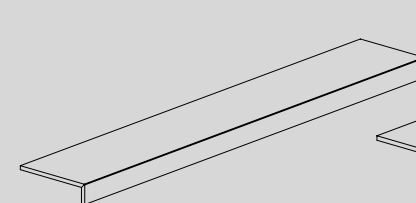
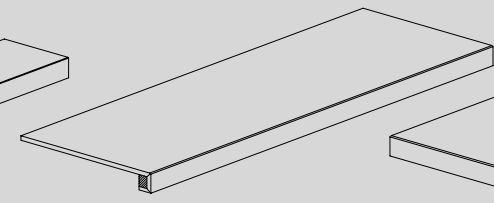
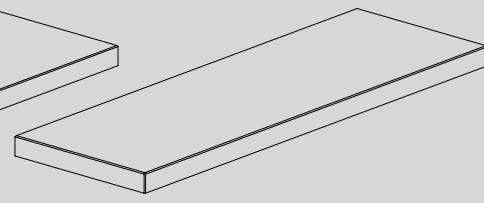
Special pieces - Pezzi speciali - Pièces spéciales - Formstücke - Piezas especiales

			
<b>BATTISCOPA 7,1x120 - 3"x47"</b>	<b>ELEMENTO A ELLE INCOLLATO 20x120 - 8"x47"</b>	<b>GRADONE COSTA RETTA 120x33 - 47"x13"</b>	<b>GRADONE ANGOLARE COSTA RETTA DX/SX 120x33 - 47"x13"</b>
NATURALE RETT. ● 19	GRIP RETT. ● 213	NATURALE RETT. ● 333	NATURALE RETT. ● 345

Packaging - Imballi - Emballages - Verpackung - Embalajes

FLOOR TILES / PAVIMENTI / PAVIMENTS / GRUNDFLIESEN / AZULEJOS							
	sizes formati formats Formate formatos	30x120 12"x47"	20x120 8"x47"	23x100 9"x40"	120x120 47"x47"	29x29 11"x11" mosaico	30x30 2,5x2,5 12"x12" <sup>1"x1"</sup> mosaico
 boxes colli boîtes Kartons cajas	pc.	3	4	5	2	5	11 fogli
	m <sup>2</sup>	1,08	0,96	1,15	2,88	0,42	1
	kg	21,7	21,6	24,00	58,00	7,5	20,30
 pallets palette Paletts paletas	colli	36	32	48	20		36
	m <sup>2</sup>	38,88	30,72	55,2	57,6		36,00
	kg	781,2	691,2	1152	1160		730,8

SPECIAL PIECES / PEZZI SPECIALI / PIÈCES SPÉCIALES / FORMSTÜCKE / PIEZAS ESPECIALES					
	sizes formati formats Formate formatos	7,1x120 3"x47" battiscopa	20x120 8"x47" elemento a elle incollato	33x120 13"x47" gradone costa retta	33x120 13"x47" gradone angolare costa retta
 boxes colli boîtes Kartons cajas	pc.	6	2	1	1
	ml	7,2	2,4	1,2	1,2
	kg	10,2	12,8	11,15	11,7

When laying you are recommended not to stagger more than about 20 cm (for the 100 cm), 30 cm (for the 120 cm). Recommended joint, minimum 2 mm.

Posa consigliata con una sfalsatura non superiore a 20 cm (per il 100 cm), 30 cm (per il 120 cm) e fuga minima raccomandata 2 mm. Pose conseillée avec decalage pas supérieur a 20 cm (pour le100 cm), 30 cm (pour le 120 cm). Joint recommande minimum de 2 mm. Empfohlene Verlegung nicht mehr als 20 cm (für 100 cm) , 30 cm (für 120 cm) versetzt und mit einer Fuge von mindestens 2 mm. Posa recomendada no más de 20 cm por el 100 cm, 30 cm por el120 cm y escada mínimo de 2 mm.

Slip - Scivolosità - Glisance - Rutschwert - Adherencia

	Standard Norma Standard   Norm   Norme   Norme	Natural Surface Superficie Natural   Surface Naturelle Natur Oberflächen   Superficie Natural	Grip Surface Superficie Grip   Surface Grip Grip Oberflächen   Superficie Grip
	B.C.R.A. (D.M.I. n. 236 μ>0,4)	> 0,40	> 0,40
	ANSI A326.3 (DCOF WET >0,42)	> 0,42	> 0,42
	DIN EN 16165 ANNEX B	R10	R11
	DIN EN 16165 ANNEX A	A+B+C MOSAICO 2,5x2,5	A+B+C
	BS EN 16165 ANNEX C	-	≥ 36 Dry / ≥ 36 Wet
	AS 4586	-	Class P4

wood effect - effetto legno - effet bois - holz-effekt - efecto madera



## Index

The Company  
Technology  
Sizes  
Thicknesses  
Surfaces  
Porcelain stoneware  
Ecologycare  
Certifications  
Quality and Safety  
Ceramic of Italy  
Fincibec Group  
Campus  
Engineering  
Pools & Wellness  
Facades  
Raised Flooring  
Technical Specifications

### Contents by collection

Archè  
**Ashley**  
Azimuth  
Blade  
Charisma  
Dicta  
Dolomite  
Esprit  
Evolution  
Gamut  
Geobrick  
Graphis  
On Stage  
Pietra Castello  
Pietre Naturali  
Tradition  
Transalp  
Woodtime  
Yukon  
Major

### Contents by effect

WOOD - Legno  
MARBLE - Marmo  
STONE - Pietra  
CONCRETE - Cemento

### Color Index

Color Index Major 20mm

# Woodtime

Fine porcelain stoneware - Gres fine porcellanato  
Grès cérame fin - Feinsteinzeug - Gres fine porcelánico

download  
catalogue



Colours - Colori  
Couleurs - Farben - Colores

Abete Bianco

Carpino

Larice

Castagno

Iroko

Sizes - Formati  
Formats - Formaten - Formatos

30x120 cm  
20x120 cm

Thicknesses - Spessori  
Epaisseurs - Dicken - Espesores

9 mm

Surfaces - Superfici  
Surfaces - Oberflächen - Superficies

Natural - Naturale  
Naturelle - Natur - Natural

Grip

Edges - Bordi  
Bordes - Kanten - Bordes

Rectified - Rettificato  
Rectifié - Rektifiziert - Rectificado

ISO 13006 Bla - EN 14411/G  
Fully-resistant flooring  
Pavimenti a resistenza totale  
Sols à résistance totale - Absolut widerständige  
Fußböden - Pavimentos de resistencia total



**c5** Floor tiles recommended for heavy uses.  
Piastrille da pavimento consigliate per calpestio intenso.  
Carreaux de sol recommandés pour un trafic piétonnier intense.  
Bodenfliesen, empfohlen für intensive Beanspruchung.  
Baldosas de suelo recomendadas para tránsito intenso.

wood effect - effetto legno - effet bois - holz-effekt - efecto madera

## Index

- The Company
- Technology
- Sizes
- Thicknesses
- Surfaces
- Porcelain stoneware
- Ecologycare
- Certifications
- Quality and Safety
- Ceramic of Italy
- Fincibec Group
- Campus
- Engineering
- Pools & Wellness
- Facades
- Raised Flooring
- Technical Specifications

### > Contents by collection

- |           |                 |
|-----------|-----------------|
| Archè     | Geobrick        |
| Ashley    | Graphis         |
| Azimuth   | On Stage        |
| Blade     | Pietra Castello |
| Charisma  | Pietre Naturali |
| Dicta     | Tradition       |
| Dolomite  | Transalp        |
| Esprit    | <b>Woodtime</b> |
| Evolution | Yukon           |
| Gamut     | Major           |

### > Contents by effect

- WOOD - Legno
- MARBLE - Marmo
- STONE - Pietra
- CONCRETE - Cemento

### > Color Index

Color Index Major 20mm

**V3** Medium variation - Media variazione  
Moyenne variation  
Mittlerer Farbunterschied  
Media Variación

## Abete Bianco



SUPERFICIE NATURALE / BORDO RETTIFICATO		A R10	
30x120 - 12"x47"	9	89257	87
20x120 - 8"x47"	9	88241	87

SUPERFICIE GRIP / BORDO RETTIFICATO		A+B+C R11	
20x120 - 8"x47"	9	88239	87

## Carpino



SUPERFICIE NATURALE / BORDO RETTIFICATO		A R10	
30x120 - 12"x47"	9	89272	87
20x120 - 8"x47"	9	89270	87

SUPERFICIE GRIP / BORDO RETTIFICATO		A+B+C R11	
20x120 - 8"x47"	9	89268	87

## Larice



SUPERFICIE NATURALE / BORDO RETTIFICATO		A R10	
30x120 - 12"x47"	9	89263	87
20x120 - 8"x47"	9	88231	87

SUPERFICIE GRIP / BORDO RETTIFICATO		A+B+C R11	
20x120 - 8"x47"	9	88233	87

## Castagno



SUPERFICIE NATURALE / BORDO RETTIFICATO		A R10	
30x120 - 12"x47"	9	89259	87
20x120 - 8"x47"	9	88246	87

SUPERFICIE GRIP / BORDO RETTIFICATO		A+B+C R11	
20x120 - 8"x47"	9	88244	87

# Index

- The Company
- Technology
- Sizes
- Thicknesses
- Surfaces
- Porcelain stoneware
- Ecologycare
- Certifications
- Quality and Safety
- Ceramic of Italy
- Fincibec Group
- Campus
- Engineering
- Pools & Wellness
- Facades
- Raised Flooring
- Technical Specifications

## > Contents by collection

- |           |                 |
|-----------|-----------------|
| Archè     | Geobrick        |
| Ashley    | Graphis         |
| Azimuth   | On Stage        |
| Blade     | Pietra Castello |
| Charisma  | Pietre Naturali |
| Dicta     | Tradition       |
| Dolomite  | Transalp        |
| Esprit    | <b>Woodtime</b> |
| Evolution | Yukon           |
| Gamut     | Major           |

## > Contents by effect

- WOOD - Legno
- MARBLE - Marmo
- STONE - Pietra
- CONCRETE - Cemento

## > Color Index

Color Index Major 20mm

## Iroko

## Decors - Decori - Eléments décoratifs - Dekore - Decoraciones



### SUPERFICIE NATURALE / BORDO RETTIFICATO

\* MAXI 19x120 - 7,5"x47"

LARICE	9	89621	143
CASTAGNO	9	89619	143
CARPINO	9	89617	143
IROKO	9	89620	143

#### \* Two versions

- Due versioni
- Deux versions
- Zwei Ausführungen
- Dos versiones

## Mosaics - Mosaici - Mosaïques - Mosaik - Mosaicos

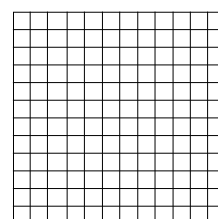

### SUPERFICIE NATURALE

A+B+C

MOSAICO 2,5x2,5 - 1"x1" SU FOGLIO 30x30 - 12"x12"

LARICE	9	89527	297
ABETE BIANCO	9	89528	297
CASTAGNO	9	89529	297
CARPINO	9	89530	297
IROKO	9	89531	297

<b>SUPERFICIE NATURALE / BORDO RETTIFICATO</b>		<b>A R10</b>	
30x120 - 12"x47"	9	89261	87
20x120 - 8"x47"	9	88252	87

<b>SUPERFICIE GRIP / BORDO RETTIFICATO</b>		<b>A+B+C R11</b>	
20x120 - 8"x47"	9	88250	87

- The Company
- Technology
- Sizes
- Thicknesses
- Surfaces
- Porcelain stoneware
- Ecologycare
- Certifications
- Quality and Safety
- Ceramic of Italy
- Fincibec Group
- Campus
- Engineering
- Pools & Wellness
- Facades
- Raised Flooring
- Technical Specifications

## Contents by collection

- |           |                 |
|-----------|-----------------|
| Archè     | Geobrick        |
| Ashley    | Graphis         |
| Azimuth   | On Stage        |
| Blade     | Pietra Castello |
| Charisma  | Pietre Naturali |
| Dicta     | Tradition       |
| Dolomite  | Transalp        |
| Esprit    | <b>Woodtime</b> |
| Evolution | Yukon           |
| Gamut     | Major           |

## Contents by effect

- WOOD - Legno
- MARBLE - Marmo
- STONE - Pietra
- CONCRETE - Cemento

## Color Index

Color Index Major 20mm

## Special pieces - Pezzi speciali - Pièces spéciales - Formstücke - Piezas especiales



**BATTISCOPIA 7,2x60 - 2,8"x24"**  
NATURALE RETTIFICATO ● 10

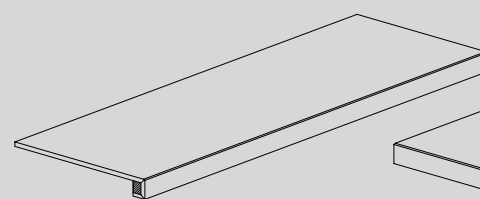

**GRADONE COSTA RETTA 120x33 - 47"x13"**  
NATURALE RETT. ● 333

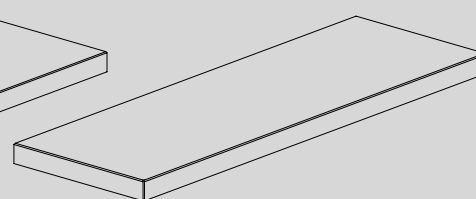

**GRADONE ANGOLARE COSTA RETTA DX/SX 120x33 - 47"x13"**  
NATURALE RETT. ● 345

## Packaging - Imballi - Emballages - Verpackung - Embalajes

### FLOOR TILES / PAVIMENTI / PAVIMENTS / GRUNDFLIESEN / AZULEJOS

	30x120 12"x47"	20x120 8"x47"	19x120 7,5"x47" maxi	30x30 2,5x2,5 12"x12" 1"x1" mosaico
boxes colli boîtes Kartons cajas	pc. 3	4	2	11 fogli
	m <sup>2</sup> 1,08	0,96	0,46	1
	kg 22,5	21,6	10,0	20,3
pallets pallet palette Paletts paletas	colli 36	32		
	m <sup>2</sup> 38,9	30,7		
	kg 810	691		

### SPECIAL PIECES / PEZZI SPECIALI / PIÈCES SPÉCIALES / FORMSTÜCKE / PIEZAS ESPECIALES

	7,2x60 2,8"x24" battiscopa	33x120 13"x47" gradone costa retta	33x120 13"x47" gradone angolare costa retta
boxes colli boîtes Kartons cajas	pc. 14	1	1
	ml 8,4	1,2	1,2
	kg 16,1	11,2	11,7

When laying you are recommended not to stagger more than about, 30 cm. Recommended joint, minimum 2 mm.  
Posa consigliata con una sfalsatura non superiore a 30 cm e fuga minima raccomandata 2 mm.  
Pose conseillée avec décalage pas supérieur à 30 cm. Joint recommandé minimum de 2 mm.  
Empfohlene Verlegung nicht mehr als 30 cm versetzt und mit einer Fuge von mindestens 2 mm.  
Posa recomendada no más de 30 cm, y escape mínimo de 2 mm.

## Slip - Scivolosità - Glissance - Rutschwert - Adherencia

	Standard Norma Standard   Norm   Norme   Norme	Natural Surface Superficie Natural   Surface Naturelle Natur Oberflächen   Superficie Natural	Grip Surface Superficie Grip   Surface Grip Grip Oberflächen   Superficie Grip
	B.C.R.A. (D.M.I. n. 236 μ>0,4)	> 0,40	> 0,40
	ANSI A326.3 (DCOF WET >0,42)	> 0,42	> 0,42
	DIN EN 16165 ANNEX B	R10	R11
	DIN EN 16165 ANNEX A	A / A+B+C MOSAICO 2,5x2,5	A+B+C
	BS EN 16165 ANNEX C	-	≥ 36 DRY / ≥ 36 WET
	AS 4586	-	Class P4

# Yukon

Fine porcelain stoneware - Gres fine porcellanato  
Grès cérame fin - Feinsteinzeug - Gres fine porcelánico



Colours - Colori  
Couleurs - Farben - Coiores

Sizes - Formati  
Formats - Formaten - Formatos

Surfaces - Superfici  
Surfaces - Oberflächen - Superficies

Klondike

Watson

Mayo

Atlin

23x100 cm

Thicknesses - Spessori  
Epaisseurs - Dicken - Espesores

9 mm

Natural - Naturale  
Naturelle - Natur - Natural

Edges - Bordi  
Bordes - Kanten - Bordes

Natural - Naturale  
Naturel - Natur - Natural

**V4** Strong variation - Intensa variazione  
Variation intense  
Starke Farbunterschied  
Variación intensa

ISO 13006 BlA - EN 14411/G  
Fully-resistant flooring  
Pavimenti a resistenza totale  
Sols à résistance totale - Absolut widerständige  
Fußböden - Pavimentos de resistencia total



**c5** Floor tiles recommended for heavy uses.  
Piastrille da pavimento consigliate per calpestio intenso.  
Carreaux de sol recommandés pour un trafic piétonnier intense.  
Bodenfliesen, empfohlen für intensive Beanspruchung.  
Baldosas de suelo recomendadas para tránsito intenso.

wood effect - effetto legno - effet bois - holz-effekt - efecto madera

## Index

- The Company
- Technology
- Sizes
- Thicknesses
- Surfaces
- Porcelain stoneware
- Ecologycare
- Certifications
- Quality and Safety
- Ceramic of Italy
- Fincibec Group
- Campus
- Engineering
- Pools & Wellness
- Facades
- Raised Flooring
- Technical Specifications

### > Contents by collection

- |           |                 |
|-----------|-----------------|
| Archè     | Geobrick        |
| Ashley    | Graphis         |
| Azimuth   | On Stage        |
| Blade     | Pietra Castello |
| Charisma  | Pietre Naturali |
| Dicta     | Tradition       |
| Dolomite  | Transalp        |
| Esprit    | Woodtime        |
| Evolution | <b>Yukon</b>    |
| Gamut     | Major           |

### > Contents by effect

- WOOD - Legno
- MARBLE - Marmo
- STONE - Pietra
- CONCRETE - Cemento

### > Color Index

Color Index Major 20mm

## Klondike

## Watson



**SUPERFICIE NATURALE / BORDO NATURALE** **A+B R10**  
23x100 - 9"x40" | 9 95983 ■ 59



**SUPERFICIE NATURALE / BORDO NATURALE** **A+B R10**  
23x100 - 9"x40" | 9 95992 ■ 59

## Mayo

## Atlin



**SUPERFICIE NATURALE / BORDO NATURALE** **A+B R10**  
23x100 - 9"x40" | 9 95985 ■ 59



**SUPERFICIE NATURALE / BORDO NATURALE** **A+B R10**  
23x100 - 9"x40" | 9 95982 ■ 59

# Index

- The Company
- Technology
- Sizes
- Thicknesses
- Surfaces
- Porcelain stoneware
- Ecologycare
- Certifications
- Quality and Safety
- Ceramic of Italy
- Fincibec Group
- Campus
- Engineering
- Pools & Wellness
- Facades
- Raised Flooring
- Technical Specifications

## > Contents by collection

- |           |                 |
|-----------|-----------------|
| Archè     | Geobrick        |
| Ashley    | Graphis         |
| Azimuth   | On Stage        |
| Blade     | Pietra Castello |
| Charisma  | Pietre Naturali |
| Dicta     | Tradition       |
| Dolomite  | Transalp        |
| Esprit    | Woodtime        |
| Evolution | <b>Yukon</b>    |
| Gamut     | Major           |

## > Contents by effect

- WOOD - Legno
- MARBLE - Marmo
- STONE - Pietra
- CONCRETE - Cemento

## > Color Index

Color Index Major 20mm

## Decors - Decorì - Éléments décoratifs - Dekore - Decoraciones



### SUPERFICIE NATURALE /BORDO NATURALE

* FORMELLA DECORO 23x23 - 9"x9"	9	81825	223
---------------------------------	---	-------	-----

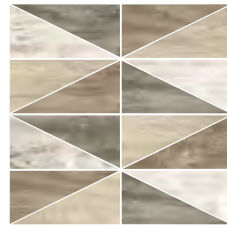

### SUPERFICIE NATURALE /BORDO NATURALE

* FORMELLA INTARSIO 23x23 - 9"x9"	9	83110	83
-----------------------------------	---	-------	----

\*Decors version with multiple subjects, packaged randomly (Matchable with all colours)

Versione decoro con più soggetti, confezionati random (Abbinabili a tutti i colori)

Version décoration avec plusieurs motifs, emballés de manière aléatoire (pouvant être assortis à toutes les couleurs)

Dekorierter Ausführung mit mehreren Darstellungen, zufällige Zusammenstellung (kann mit allen Farben kombiniert werden)

Versión decoración con varios temas, empaquetados de modo aleatorio (se puede combinar con todos los colores)

## Mosaics - Mosaici - Mosaïques - Mosaik - Mosaicos

SUPERFICIE NATURALE		A+B+C	
MOSAICO 2,5x2,5 - 1"x1" SU FOGLIO 30x30 - 12"x12"			
KLONDIKE	9	86249	297
MAYO	9	86252	297
ATLIN	9	86254	297
WATSON	9	86253	297

## Special pieces - Pezzi speciali - Pièces spéciales - Formstücke - Piezas especiales



BATTISCOPA 7,1x100 - 3"x40"	16
NATURALE	16

## Packaging - Imballi - Emballages - Verpackung - Embalajes

FLOOR TILES / PAVIMENTI / PAVIMENTS / GRUNDFLIESEN / AZULEJOS						
	sizes formati formats Formate formatos	23x100 9"x40"	23x23 9"x9" formella decoro	23x23 9"x9" formella intarsio	30x30 2,5x2,5 12"x12" 1"x1" mosaico	
	boxes colli boîtes Kartons cajas	pc.	5	16	4	11 fogli
		m <sup>2</sup>	1,15	0,85	0,21	1
		kg	24,0	17,0	2,5	20,3
	pallets pallet palette Paletts paletas	colli	48			
		m <sup>2</sup>	55,2			
		kg	1152			

SPECIAL PIECES / PEZZI SPECIALI / PIÈCES SPÉCIALES / FORMSTÜCKE / PIEZAS ESPECIALES		
sizes formati formats Formate formatos	7,1x100 3"x40" battiscopa	
pc.	6	
ml	6	
kg	10,5	

When laying you are recommended not to stagger more than about 20 cm. Recommended joint, minimum 2 mm. Posa consigliata con una sfalsatura non superiore a 20 cm e fuga minima raccomandata 2 mm. Pose conseillée avec décalage pas supérieur à 20 cm et joint recommandé minimum de 2 mm. Empfohlene Verlegung nicht mehr als 20 cm versetzt und mit einer Fuge von mindestens 2 mm. Posa recomendada no más de 20 cm, y escape mínimo de 2 mm.

## Slip - Scivolosità - Glissance - Rutschwert - Adherencia

	Standard Norma Standard   Norm   Norme   Norme	Natural Surface Superficie Natural   Surface Naturelle Natur Oberflächen   Superficie Natural
	B.C.R.A. (D.M.I. n. 236 μ>0,4)	> 0,40
	ANSI A 326.3 (DCOF WET >0,42)	> 0,42
	DIN EN 16165 ANNEX B	R10
	DIN EN 16165 ANNEX A	A+B / A+B+C MOSAICO 2,5x2,5

- The Company
- Technology
- Sizes
- Thicknesses
- Surfaces
- Porcelain stoneware
- Ecologycare
- Certifications
- Quality and Safety
- Ceramic of Italy
- Fincibec Group
- Campus
- Engineering
- Pools & Wellness
- Facades
- Raised Flooring
- Technical Specifications

## Contents by collection

- |           |                 |
|-----------|-----------------|
| Archè     | Geobrick        |
| Ashley    | Graphis         |
| Azimuth   | On Stage        |
| Blade     | Pietra Castello |
| Charisma  | Pietre Naturali |
| Dicta     | Tradition       |
| Dolomite  | Transalp        |
| Esprit    | Woodtime        |
| Evolution | <b>Yukon</b>    |
| Gamut     | Major           |

## Contents by effect

- WOOD - Legno
- MARBLE - Marmo
- STONE - Pietra
- CONCRETE - Cemento

## Color Index

Color Index Major 20mm





Fine porcelain stoneware - Gres fine porcellanato  
Grès cérame fin - Feinsteinzeug - Gres fine porcelánico

## MARBLE EFFECT - EFFETTO MARMO

effet marbre - Marmoreffekt - efecto marmol

pag. 64 On Stage  
pag. 72 Transalp

## Index

The Company  
Technology  
Sizes  
Thicknesses  
Surfaces  
Porcelain stoneware  
Ecologycare  
Certifications  
Quality and Safety  
Ceramic of Italy  
Fincibec Group  
Campus  
Engineering  
Pools & Wellness  
Facades  
Raised Flooring  
Technical Specifications

### > Contents by collection

Archè	Geobrick
Ashley	Graphis
Azimuth	On Stage
Blade	Pietra Castello
Charisma	Pietre Naturali
Dicta	Tradition
Dolomite	Transalp
Esprit	Woodtime
Evolution	Yukon
Gamut	Major

### > Contents by effect

WOOD - Legno  
**MARBLE - Marmo**  
STONE - Pietra  
CONCRETE - Cemento

### > Color Index

Color Index Major 20mm

# On Stage

Fine porcelain stoneware - Gres fine porcellanato  
Grès cérame fin - Feinsteinzeug - Gres fine porcelánico

download catalogue

watch the video



Colours - Colori  
Couleurs - Farben - Colores

Boulevard

Riverside

Victoria

Adelphi

Fortune

Broadway

**V2** Light variation - Lieve variazione  
Variation légère  
Gerinde Farbunterschied  
Variación escasa

Sizes - Formati  
Formats - Formaten - Formatos

120x278 cm  
120x120 cm  
60x120 cm  
80x80 cm

Thicknesses - Spessori  
Epaisseurs - Dicken - Espesores

7 mm  
9 mm

Surfaces - Superfici  
Surfaces - Oberflächen - Superficies

**Natural** - Naturale  
Naturelle - Natur - Natural

**Brushed** - Molata  
Adouci - Geschliffen - Molida

**Edges** - Bordi  
Bordes - Kanten - Bordes

**Rectified** - Rettificato  
Rectifié - Rektifiziert - Rectificado

ISO 13006 Bla - EN 14411/G  
Fully-resistant flooring  
Pavimenti a resistenza totale  
Sols à résistance totale - Absolut widerständige  
Fußböden - Pavimentos de resistencia total



**c4** Floor tiles recommended for medium traffic areas.  
Piastrille da pavimento consigliate per calpestio medio.  
Carreaux de sol recommandés pour un trafic piétonnier moyen.  
Bodenfliesen, empfohlen für mittlere Beanspruchung.  
Baldosas de suelo recomendadas para el tránsito medio.

**c5** Floor tiles recommended for heavy uses.  
Piastrille da pavimento consigliate per calpestio intenso.  
Carreaux de sol recommandés pour un trafic piétonnier intense.  
Bodenfliesen, empfohlen für intensive Beanspruchung.  
Baldosas de suelo recomendadas para tránsito intenso.

marble effect - effetto marmo - effet marbre - marmoreffekt - efecto marmol

## Index

- The Company
- Technology
- Sizes
- Thicknesses
- Surfaces
- Porcelain stoneware
- Ecologycare
- Certifications
- Quality and Safety
- Ceramic of Italy
- Fincibec Group
- Campus
- Engineering
- Pools & Wellness
- Facades
- Raised Flooring
- Technical Specifications

### Contents by collection

- |           |                 |
|-----------|-----------------|
| Archè     | Geobrick        |
| Ashley    | Graphis         |
| Azimuth   | <b>On Stage</b> |
| Blade     | Pietra Castello |
| Charisma  | Pietre Naturali |
| Dicta     | Tradition       |
| Dolomite  | Transalp        |
| Esprit    | Woodtime        |
| Evolution | Yukon           |
| Gamut     | Major           |

### Contents by effect

- WOOD - Legno
- MARBLE - Marmo
- STONE - Pietra
- CONCRETE - Cemento

### Color Index

Color Index Major 20mm

## Boulevard



SUPERFICIE NATURALE / BORDO RETTIFICATO		A+B R10	
▲ 120x120 - 47"x47"	9	133034	127
60x120 - 24"x47"	9	133321	93
80x80 - 31,5"x31,5"	9	133335	93

SUPERFICIE MOLATA / BORDO RETTIFICATO			
▲ 120x120 - 47"x47"	9	133041	163
60x120 - 24"x47"	9	133328	109
80x80 - 31,5"x31,5"	9	133342	109

▲ cm 120x278 pallet surcharge 140 € - stand containing 295 €  
cm 120x278 addebito cassa 140 € - cavalla 295 €  
cm 120x278 surtaxe caisse 140 € - chevalet 295 €  
cm 120x278 Aufpreis Kiste 140 € - Ständer 295 €  
cm 120x278 recargo caja 140 € - soporte 295 €

▲ cm 120x120 split pallet surcharge 40 € each - lightened stand containing 95 €  
cm 120x120 addebito frazione di paletta 40 € - cavalla alleggerita 95 €  
cm 120x120 surtaxe contremarque 40 € - chevalet allégé 95 €  
cm 120x120 Aufpreis Teilpalette 40 € - leichter Ständer 95 €  
cm 120x120 recargo fracción de paleta 40 € - soporte ligero 95 €

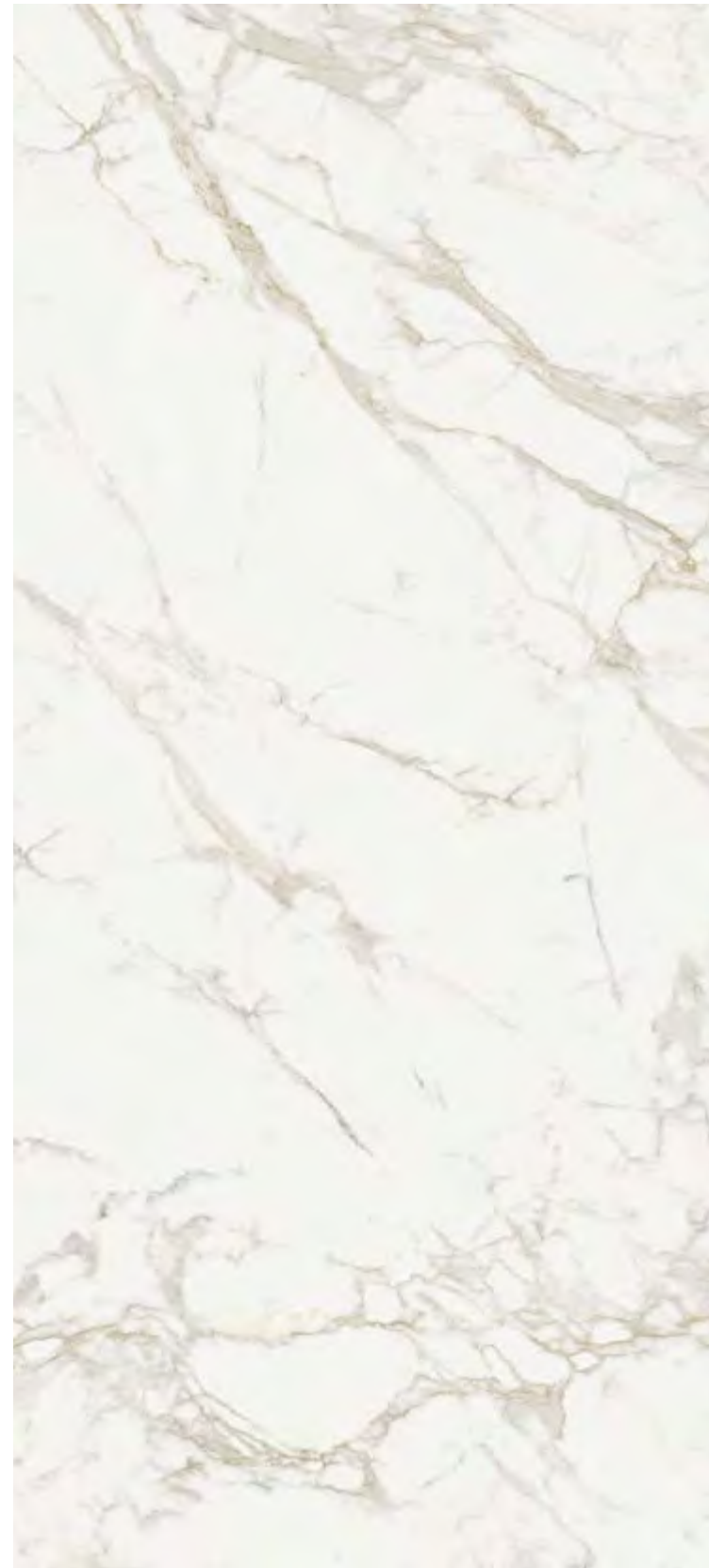

SUPERFICIE MOLATA / BORDO RETTIFICATO			
▲ 120x278 - 47"x109,5"	7	135795	213

## Victoria



SUPERFICIE NATURALE / BORDO RETTIFICATO		A+B R10	
▲ 120x120 - 47"x47"	9	133028	127
60x120 - 24"x47"	9	133316	93
80x80 - 31,5"x31,5"	9	133330	93

SUPERFICIE MOLATA / BORDO RETTIFICATO			
▲ 120x120 - 47"x47"	9	133035	163
60x120 - 24"x47"	9	133323	109
80x80 - 31,5"x31,5"	9	133337	109

▲ cm 120x278 pallet surcharge 140 € - stand containing 295 €  
cm 120x278 addebito cassa 140 € - cavalla 295 €  
cm 120x278 surtaxe caisse 140 € - chevalet 295 €  
cm 120x278 Aufpreis Kiste 140 € - Ständer 295 €  
cm 120x278 recargo caja 140 € - soporte 295 €

▲ cm 120x120 split pallet surcharge 40 € each - lightened stand containing 95 €  
cm 120x120 addebito frazione di paletta 40 € - cavalla alleggerita 95 €  
cm 120x120 surtaxe contremarque 40 € - chevalet allégé 95 €  
cm 120x120 Aufpreis Teilpalette 40 € - leichter Ständer 95 €  
cm 120x120 recargo fracción de paleta 40 € - soporte ligero 95 €



SUPERFICIE MOLATA / BORDO RETTIFICATO			
▲ 120x278 - 47"x109,5"	7	135796	213

# Index

- The Company
- Technology
- Sizes
- Thicknesses
- Surfaces
- Porcelain stoneware
- Ecologycare
- Certifications
- Quality and Safety
- Ceramic of Italy
- Fincibec Group
- Campus
- Engineering
- Pools & Wellness
- Facades
- Raised Flooring
- Technical Specifications

## Contents by collection

- |           |                 |
|-----------|-----------------|
| Archè     | Geobrick        |
| Ashley    | Graphis         |
| Azimuth   | <b>On Stage</b> |
| Blade     | Pietra Castello |
| Charisma  | Pietre Naturali |
| Dicta     | Tradition       |
| Dolomite  | Transalp        |
| Esprit    | Woodtime        |
| Evolution | Yukon           |
| Gamut     | Major           |

## Contents by effect

- WOOD - Legno
- MARBLE - Marmo
- STONE - Pietra
- CONCRETE - Cemento

## Color Index

Color Index Major 20mm

# On Stage

Fine porcelain stoneware - Gres fine porcellanato  
Grès cérame fin - Feinsteinzeug - Gres fine porcelánico

marble effect - effetto marmo - effet marbre - marmoreffekt - efecto marmol

## Adelphi

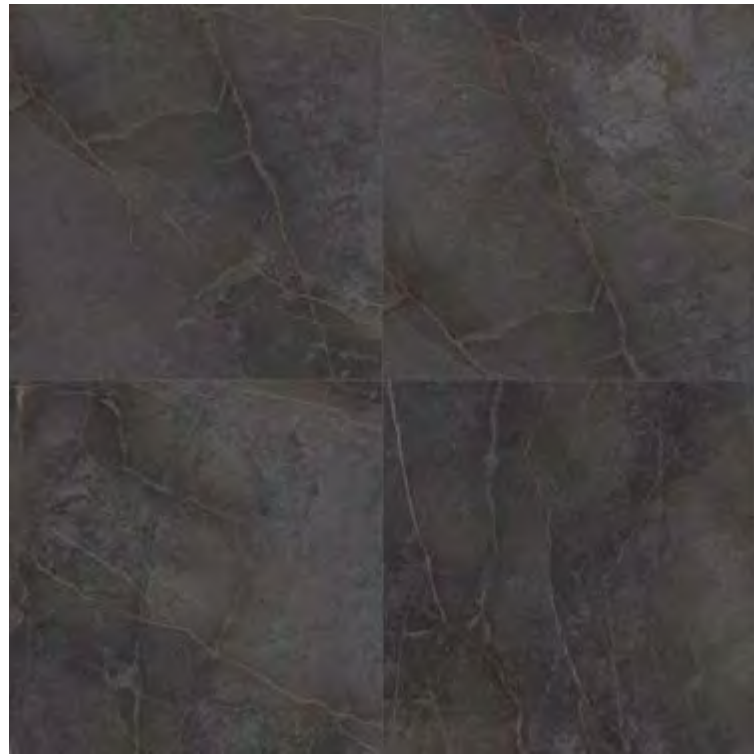

SUPERFICIE NATURALE / BORDO RETTIFICATO		A+B R10	
▲ 120x120 - 47"x47"	9	133032	127
60x120 - 24"x47"	9	133319	93
80x80 - 31,5"x31,5"	9	133333	93

SUPERFICIE MOLATA / BORDO RETTIFICATO			
▲ 120x120 - 47"x47"	9	133039	163
60x120 - 24"x47"	9	133326	109
80x80 - 31,5"x31,5"	9	133340	109

▲ cm 120x278 pallet surcharge 140 € - stand containing 295 €  
cm 120x278 addebito cassa 140 € - cavalla 295 €  
cm 120x278 surtaxe caisse 140 € - chevalet 295 €  
cm 120x278 Aufpreis Kiste 140 € - Ständer 295 €  
cm 120x278 recargo caja 140 € - soporte 295 €

▲ cm 120x120 split pallet surcharge 40 € each - lightened stand containing 95 €  
cm 120x120 addebito frazione di paletta 40 € - cavalla alleggerita 95 €  
cm 120x120 surtaxe contremarque 40 € - chevalet allégé 95 €  
cm 120x120 Aufpreis Teilpalette 40 € - leichter Ständer 95 €  
cm 120x120 recargo fracción de paleta 40 € - soporte ligero 95 €

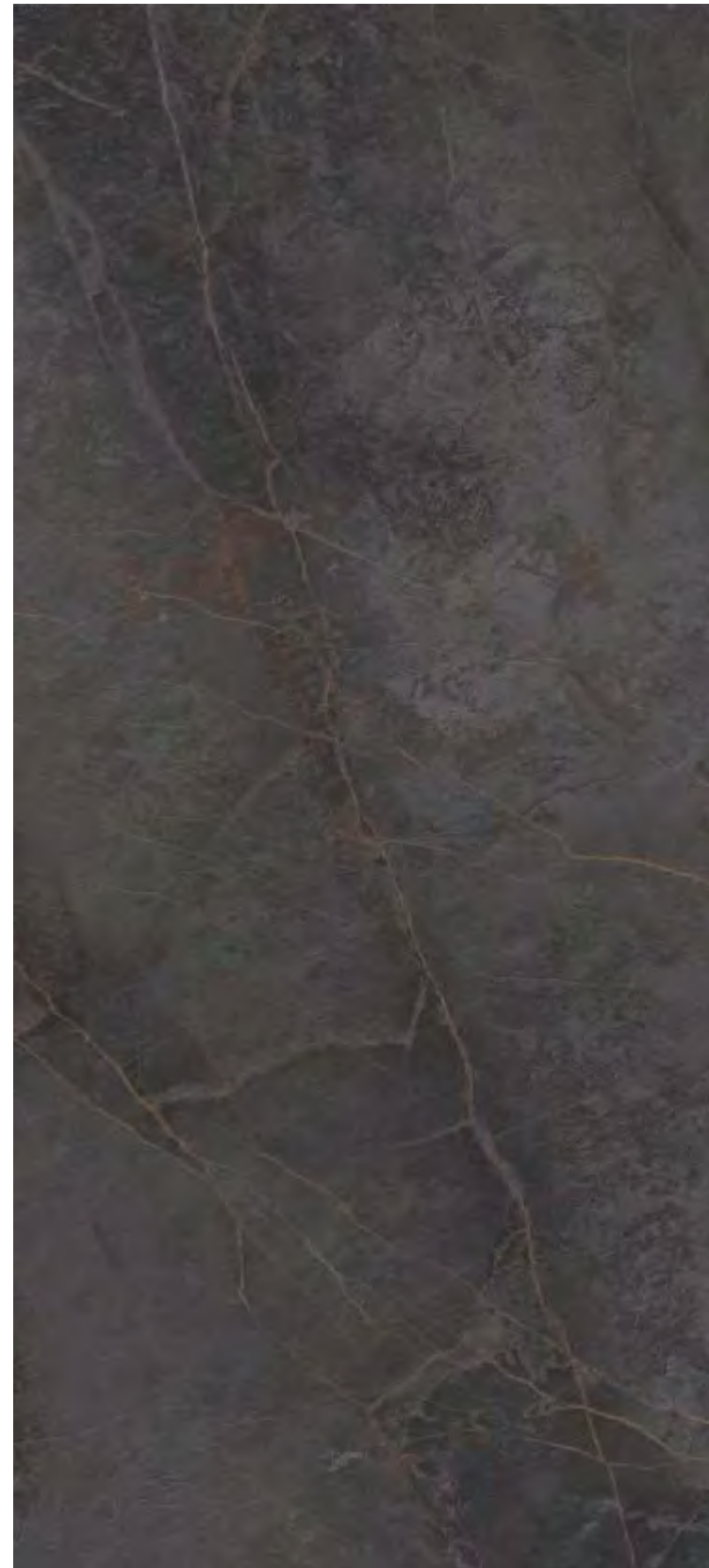

SUPERFICIE MOLATA / BORDO RETTIFICATO			
▲ 120x278 - 47"x109,5"	7	135797	213

## Riverside



SUPERFICIE NATURALE / BORDO RETTIFICATO		A+B R10	
▲ 120x120 - 47"x47"	9	133033	127
60x120 - 24"x47"	9	133317	93
80x80 - 31,5"x31,5"	9	133331	93

SUPERFICIE MOLATA / BORDO RETTIFICATO			
▲ 120x120 - 47"x47"	9	133040	163
60x120 - 24"x47"	9	133324	109
80x80 - 31,5"x31,5"	9	133338	109

## Fortune

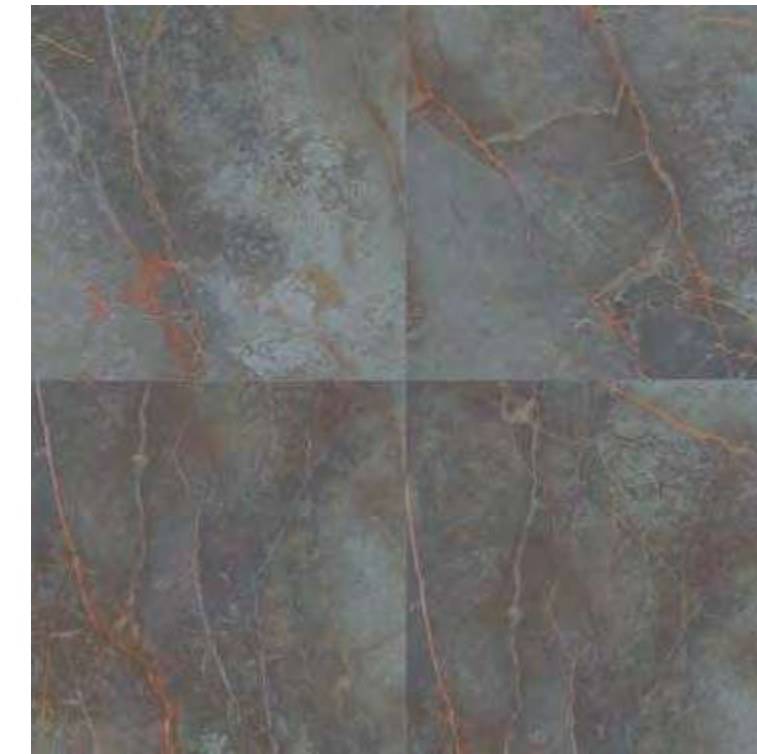

SUPERFICIE NATURALE / BORDO RETTIFICATO		A+B R10	
▲ 120x120 - 47"x47"	9	133030	127
60x120 - 24"x47"	9	133318	93
80x80 - 31,5"x31,5"	9	133332	93

SUPERFICIE MOLATA / BORDO RETTIFICATO			
▲ 120x120 - 47"x47"	9	133037	163
60x120 - 24"x47"	9	133325	109
80x80 - 31,5"x31,5"	9	133339	109

▲ cm 120x120 split pallet surcharge 40 € each - lightened stand containing 95 €  
cm 120x120 addebito frazione di paletta 40 € - cavalla alleggerita 95 €  
cm 120x120 surtaxe contremarque 40 € - chevalet allégé 95 €  
cm 120x120 Aufpreis Teilpalette 40 € - leichter Ständer 95 €  
cm 120x120 recargo fracción de paleta 40 € - soporte ligero 95 €

# Index

- The Company
- Technology
- Sizes
- Thicknesses
- Surfaces
- Porcelain stoneware
- Ecologycare
- Certifications
- Quality and Safety
- Ceramic of Italy
- Fincibec Group
- Campus
- Engineering
- Pools & Wellness
- Facades
- Raised Flooring
- Technical Specifications

## Contents by collection

- |           |                 |
|-----------|-----------------|
| Archè     | Geobrick        |
| Ashley    | Graphis         |
| Azimuth   | <b>On Stage</b> |
| Blade     | Pietra Castello |
| Charisma  | Pietre Naturali |
| Dicta     | Tradition       |
| Dolomite  | Transalp        |
| Esprit    | Woodtime        |
| Evolution | Yukon           |
| Gamut     | Major           |

## Contents by effect

- WOOD - Legno
- MARBLE - Marmo
- STONE - Pietra
- CONCRETE - Cemento

## Color Index

Color Index Major 20mm

# On Stage

Fine porcelain stoneware - Gres fine porcellanato  
Grès cérame fin - Feinsteinzeug - Gres fine porcelánico

## Broadway

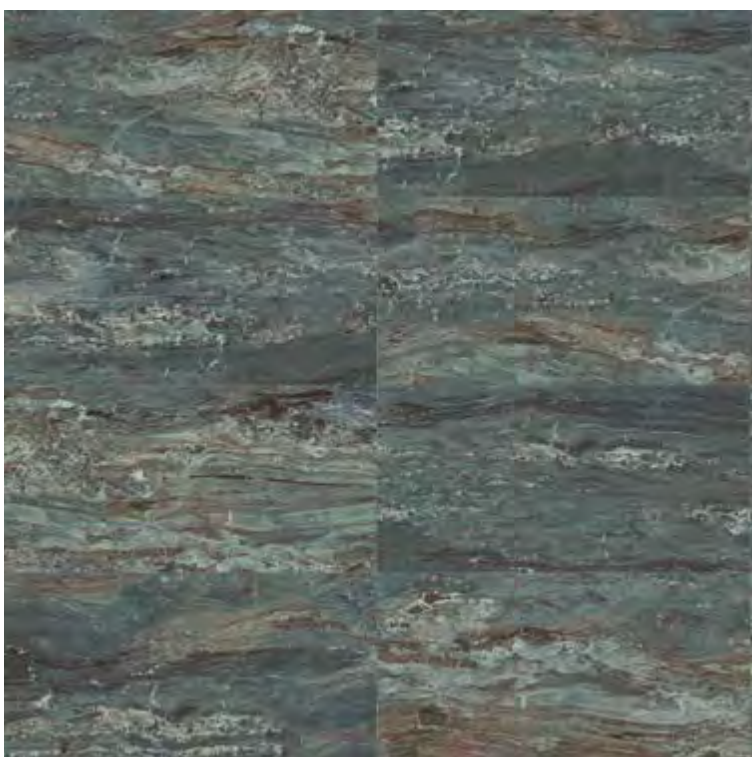

<b>SUPERFICIE NATURALE / BORDO RETTIFICATO</b>	<b>A+B R10</b>
60x120 - 24"x47"	9 133315 ■ 93

<b>SUPERFICIE MOLATA / BORDO RETTIFICATO</b>	
60x120 - 24"x47"	9 133322 ■ 109

## Decors - Decori - Eléments décoratifs - Dekore - Decoraciones



<b>SUPERFICIE NATURALE / BORDO RETTIFICATO</b>	
GROOVE VICTORIA 30x120 - 12"x47"	9 133343 ■ 163



<b>SUPERFICIE NATURALE / BORDO RETTIFICATO</b>	
GROOVE FORTUNE 30x120 - 12"x47"	9 133344 ■ 163



<b>SUPERFICIE MOLATA / BORDO RETTIFICATO</b>	
MODULO RECITAL BROADWAY 28x29 - 11"x11"	9 133519 ● 53
MODULO RECITAL ADELPHI 28x29 - 11"x11"	9 133520 ● 53



<b>SUPERFICIE MOLATA / BORDO RETTIFICATO</b>	
MODULO THEATER 32x29 - 13"x11"	9 133517 ● 53

Tiles for walls  
Piastrille per rivestimento pareti  
Carreaux de revêtement  
Wandverkleidung Fliesen  
Azulejos para revestimiento

# On Stage

Fine porcelain stoneware - Gres fine porcellanato  
Grès cérame fin - Feinsteinzeug - Gres fine porcelánico

## Mosaics - Mosaici - Mosaïques - Mosaik - Mosaicos

<b>SUPERFICIE NATURALE</b>	<b>A+B</b>
MOSAICO 4,7x4,7 - 1,8"x1,8" SU RETE 30x30 - 12"x12"	
BOULEVARD	9 133516 ■ 253
RIVERSIDE	9 133515 ■ 253
VICTORIA	9 133512 ■ 253
FORTUNE	9 133513 ■ 253
ADELPHI	9 133514 ■ 253
BROADWAY	9 133510 ■ 253

## Special pieces - Pezzi speciali - Pièces spéciales - Formstücke - Piezas especiales

<b>BATTISCOPA 120x7,1 - 47"x3"</b>	<b>GRADONE COSTA RETTA 120x33 - 47"x13"</b>	<b>GRADONE ANGOLARE COSTA RETTA DX/SX 120x33 - 47"x13"</b>
NATURALE RETT. ● 19	NATURALE RETT. ● 333	NATURALE RETT. ● 345
	MOLATA RETT. ● 337	MOLATA RETT. ● 349

## Packaging - Imballi - Emballages - Verpackung - Embalajes

FLOOR TILES / PAVIMENTI / PAVIMENTS / GRUNDFLIESEN / AZULEJOS									
	sizes formati formats Formate formatos	120x278 47"x109,5"	120x120 47"x47"	60x120 24"x47"	30x120 12"x47"	80x80 31,5"x31,5"	32x29 13"x12" Mod. Teather	28x29 11"x12" Mod. Recital	30x30 4,7x4,7 12"x12" 1,8"x1,8" mosaico
boxes colli boîtes Kartons cajas	pc.	CASSA 20	2	2	3	2	5	5	11
	m <sup>2</sup>	66,7	2,88	1,44	1,08	1,28	0,46	0,41	1
	kg	1250	58	31	23	26,2	9,3	8,7	20,30
pallets palette Paletts paletas	colli	CAVALLA 36	20	35	36	40	-	-	-
	m <sup>2</sup>	120,2	57,6	50,4	38,88	51,2	-	-	-
	kg	2230	1160	1085	828	1048	-	-	-

SPECIAL PIECES / PEZZI SPECIALI / PIÈCES SPÉCIALES / FORMSTÜCKE / PIEZAS ESPECIALES			
sizes formati formats Formate formatos	7,1x120 3"x47" battiscopa	33x120 13"x47" gradone costa retta	33x120 13"x47" gradone angolare costa retta
boxes colli boîtes Kartons cajas	pc.	6	1
	ml	7,2	1,2
	kg	10,2	11,2

## Slip - Scivolosità - Glissance - Rutschwert - Adherencia

	Standard Norma Standard   Norm   Norme   Norme	Natural Surface Superficie Naturale   Surface Naturelle Natur Oberflächen   Superficie Natural	Brushed Surface Superficie Molata   Surface Adouci Geschliffen Oberflächen   Superficie Molida
	B.C.R.A. (D.M.I. n. 236 μ>0,4)	> 0,40	-
	ANSI A 326.3 (DCOF WET >0,42)	> 0,42	> 0,42
	DIN EN 16165 ANNEX B	R10	-
	DIN EN 16165 ANNEX A	A+B / A+B MOSAICO 4,7x4,7	-

# Index

- The Company
- Technology
- Sizes
- Thicknesses
- Surfaces
- Porcelain stoneware
- Ecologycare
- Certifications
- Quality and Safety
- Ceramic of Italy
- Fincibec Group
- Campus
- Engineering
- Pools & Wellness
- Facades
- Raised Flooring
- Technical Specifications

## Contents by collection

- |           |                 |
|-----------|-----------------|
| Archè     | Geobrick        |
| Ashley    | Graphis         |
| Azimuth   | <b>On Stage</b> |
| Blade     | Pietra Castello |
| Charisma  | Pietre Naturali |
| Dicta     | Tradition       |
| Dolomite  | Transalp        |
| Esprit    | Woodtime        |
| Evolution | Yukon           |
| Gamut     | Major           |

## Contents by effect

- WOOD - Legno
- MARBLE - Marmo
- STONE - Pietra
- CONCRETE - Cemento

## Color Index

Color Index Major 20mm

# Transalp

Fine porcelain stoneware - Gres fine porcellanato  
Grès cérame fin - Feinsteinzeug - Gres fine porcelánico



Colours - Colori  
Couleurs - Farben - Cores

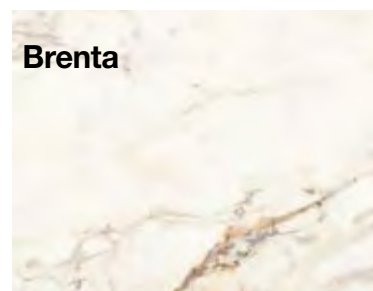

Brenta

Sizes - Formati  
Formats - Formaten - Formatos

120x278 cm  
(\*120x260 cm)  
120x120 cm

Thicknesses - Spessori  
Épaisseurs - Dicken - Espesores

7 mm  
9 mm

Surfaces - Superfici  
Surfaces - Oberflächen - Superficies

Polished - Levigata  
Polie - Polierte - Pulida

Edges - Bordi  
Bordes - Kanten - Bordes

Rectified - Rettificato  
Rectifié - Rektifiziert - Rectificado

ISO 13006 B1a - EN 14411/G  
Fully-resistant flooring  
Pavimenti a resistenza totale  
Sols à résistance totale - Absolut widerständige  
Fußböden - Pavimentos de resistencia total



**c4** Floor tiles recommended for medium traffic areas.  
Piastrille da pavimento consigliate per calpestio medio.  
Carreaux de sol recommandés pour un trafic piétonnier moyen.  
Bodenfliesen, empfohlen für mittlere Beanspruchung.  
Baldosas de suelo recomendadas para el tránsito medio.

**V2** Light variation - Lieve variazione  
Variation légère  
Gerinde Farbunterschied  
Variación escasa

\* cm 120x260  
after after out of stock  
fino ad esaurimento scorte  
jusqu'à épuisement des stocks  
hasta agotar el stock  
solange der Vorrat reicht

marble effect - effetto marmo - effet marbre - marmoreffekt - efecto marmol

## Index

The Company  
Technology  
Sizes  
Thicknesses  
Surfaces  
Porcelain stoneware  
Ecologycare  
Certifications  
Quality and Safety  
Ceramic of Italy  
Fincibec Group  
Campus  
Engineering  
Pools & Wellness  
Facades  
Raised Flooring  
Technical Specifications

### > Contents by collection

Archè	Geobrick
Ashley	Graphis
Azimuth	On Stage
Blade	Pietra Castello
Charisma	Pietre Naturali
Dicta	Tradition
Dolomite	<b>Transalp</b>
Esprit	Woodtime
Evolution	Yukon
Gamut	Major

### > Contents by effect

WOOD - Legno  
MARBLE - Marmo  
STONE - Pietra  
CONCRETE - Cemento

### > Color Index

Color Index Major 20mm

## Brenta



### SUPERFICIE LEVIGATA / BORDO RETTIFICATO

▲ 120x120 - 47"x47" 9 106223 ■ 203



### SUPERFICIE LEVIGATA / BORDO RETTIFICATO

▲ 120x260 - 47"x102" 7 115255 ■ 253  
▲ 120x278 - 47"x109" 7 138446 ■ 253

\* cm 120x260  
after after out of stock  
fino ad esaurimento scorte  
jusqu'à épuisement des stocks  
hasta agotar el stock  
solange der Vorrat reicht

▲ cm 120x278/120x260 pallet surcharge 140 € - stand containing 295 €  
cm 120x278/120x260 addebito cassa 140 € - cavalla 295 €  
cm 120x278/120x260 surtaxe caisse 140 € - chevalet 295 €  
cm 120x278/120x260 Aufpreis Kiste 140 € - Ständer 295 €  
cm 120x278/120x260 recargo caja 140 € - soporte 295 €

▲ cm 120x120 split pallet surcharge 40 € each - lightened stand containing 95 €  
cm 120x120 addebito frazione di paletta 40 € - cavalla alleggerita 95 €  
cm 120x120 surtaxe contremarque 40 € - chevalet allégé 95 €  
cm 120x120 Aufpreis Teilpalette 40 € - leichter Ständer 95 €  
cm 120x120 recargo fracción de paleta 40 € - soporte ligero 95 €

## Special pieces - Pezzi speciali - Pièces spéciales - Formstücke - Piezas especiales

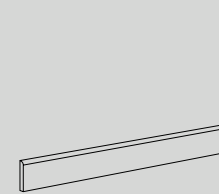

BATTISCOPIA 7,1x120 - 3"x47"  
LEVIGATA RETT. ● 32

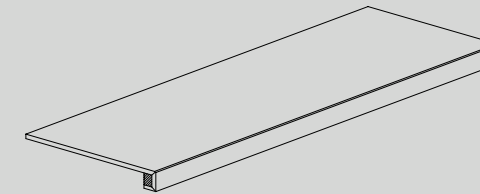

GRADONE COSTA RETTA 120x33 - 47"x13"  
LEVIGATA RETT. ● 341

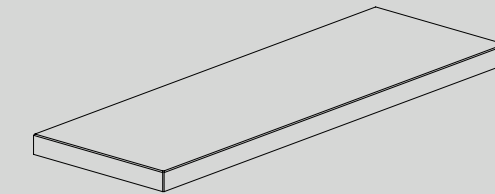

GRADONE ANGOLARE COSTA RETTA DX/SX 120x33 - 47"x13"  
LEVIGATA RETT. ● 357

## Packaging - Imballi - Emballages - Verpackung - Embalajes

### FLOOR TILES / PAVIMENTI / PAVIMENTS / GRUNDFLIESEN / AZULEJOS

	sizes formati formats Formate formatos	120x278 47"x109,5"	120x260 47"x102"	120x120 47"x47"
boxes colli boîtes Kartons cajas	pc.	CASSA 20	CASSA 20	2
	m <sup>2</sup>	66,7	62,4	2,88
	kg	1130	1060	58
pallets pallet paletts paletas	colli	CAVALLA 36	CAVALLA 36	20
	m <sup>2</sup>	120,2	112,3	57,6
	kg	2230	1908	1160

### SPECIAL PIECES / PEZZI SPECIALI / PIÈCES SPÉCIALES / FORMSTÜCKE / PIEZAS ESPECIALES

	sizes formati formats Formate formatos	7,1x120 3"x47" battiscopa	33x120 13"x47" gradone costa retta	33x120 13"x47" gradone angolare costa retta
boxes colli boîtes Kartons cajas	pc.	6	1	1
	ml	7,2	1,2	1,2
	kg	10,2	11,2	11,7

## Slip - Scivolosità - Glissance - Rutschwert - Adherencia

	Standard Norma Standard   Norm   Norme   Norme	Polished Surface Superficie Levigata   Surface Polie Polierte Oberflächen   Superficie Pulida
	B.C.R.A. (D.M.I. n. 236 μ>0,4)	-
	ANSI A 326.3 (DCOF WET >0,42)	-
	DIN EN 16165 ANNEX B	-
	DIN EN 16165 ANNEX A	-

# Index

- The Company
- Technology
- Sizes
- Thicknesses
- Surfaces
- Porcelain stoneware
- Ecologycare
- Certifications
- Quality and Safety
- Ceramic of Italy
- Fincibec Group
- Campus
- Engineering
- Pools & Wellness
- Facades
- Raised Flooring
- Technical Specifications

## Contents by collection

- Archè
- Ashley
- Azimuth
- Blade
- Charisma
- Dicta
- Dolomite
- Esprit
- Evolution
- Gamut
- Geobrick
- Graphis
- On Stage
- Pietra Castello
- Pietre Naturali
- Tradition
- Transalp**
- Woodtime
- Yukon
- Major

## Contents by effect

- WOOD - Legno
- MARBLE - Marmo
- STONE - Pietra
- CONCRETE - Cemento

## Color Index

Color Index Major 20mm



Fine porcelain stoneware - Gres fine porcellanato  
Grès cérame fin - Feinsteinzeug - Gres fine porcelánico

## STONE EFFECT - EFFETTO PIETRA

effet pierre - Steineffekt - efecto piedra

<i>pag. 78</i>	<b>Dicta</b>
<i>pag. 86</i>	<b>Arché</b>
<i>pag. 92</i>	<b>Azimuth</b>
<i>pag. 102</i>	<b>Pietra Castello</b>
<i>pag. 108</i>	<b>Charisma</b>
<i>pag. 116</i>	<b>Evolution</b>
<i>pag. 120</i>	<b>Dolomite</b>
<i>pag. 126</i>	<b>Geobrick</b>
<i>pag. 132</i>	<b>Pietre Naturali</b>
<i>pag. 136</i>	<b>Tradition</b>

# Index

The Company  
Technology  
Sizes  
Thicknesses  
Surfaces  
Porcelain stoneware  
Ecologycare  
Certifications  
Quality and Safety  
Ceramic of Italy  
Fincibec Group  
Campus  
Engineering  
Pools & Wellness  
Facades  
Raised Flooring  
Technical Specifications

## > Contents by collection

Archè	Geobrick
Ashley	Graphis
Azimuth	On Stage
Blade	Pietra Castello
Charisma	Pietre Naturali
Dicta	Tradition
Dolomite	Transalp
Esprit	Woodtime
Evolution	Yukon
Gamut	Major

## > Contents by effect

WOOD - Legno  
MARBLE - Marmo  
**STONE - Pietra**  
CONCRETE - Cemento

## > Color Index

Color Index Major 20mm



# Dicta

Fine porcelain stoneware - Gres fine porcellanato  
Grès cérame fin - Feinsteinzeug - Gres fine porcelánico

download  
catalogue



watch  
the video



Colours - Colori  
Couleurs - Farben - Colores

Metis

Ceres

Ariel

Eris

Thebe

Rhea

**V2** Light variation - Lieve variazione  
Variation légère  
Gerinde Farbunterschied  
Variación escasa

Sizes - Formati  
Formats - Formaten - Formatos

60x120 cm  
60x60 cm

Thicknesses - Spessori  
Epaisseurs - Dicken - Espesores

9 mm

Surfaces - Superfici  
Surfaces - Oberflächen - Superficies

Natural - Naturale  
Naturelle - Natur - Natural

Grip

Edges - Bordi  
Bordes - Kanten - Bordes

Rectified - Rettificato  
Rectifié - Rektifiziert - Rectificado

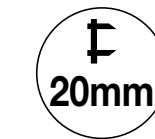

**MAJOR**  
50x100 cm

PAG. 182

ISO 13006 Bla - EN 14411/G  
Fully-resistant flooring  
Pavimenti a resistenza totale  
Sols à résistance totale - Absolut widerständige  
Fußböden - Pavimentos de resistencia total



**c5**

NATURALE

Floor tiles recommended for heavy uses.  
Piastrille da pavimento consigliate per calpestio intenso.  
Carreaux de sol recommandés pour un trafic piétonnier intense.  
Bodenfliesen, empfohlen für intensive Beanspruchung.  
Baldosas de suelo recomendadas para tránsito intenso.

stone effect - effetto pietra - effet pierre - Steineffekt - efecto piedra

## Index

The Company  
Technology  
Sizes  
Thicknesses  
Surfaces  
Porcelain stoneware  
Ecologycare  
Certifications  
Quality and Safety  
Ceramic of Italy  
Fincibec Group  
Campus  
Engineering  
Pools & Wellness  
Facades  
Raised Flooring  
Technical Specifications

### > Contents by collection

Archè	Geobrick
Ashley	Graphis
Azimuth	On Stage
Blade	Pietra Castello
Charisma	Pietre Naturali
<b>Dicta</b>	Tradition
Dolomite	Transalp
Esprit	Woodtime
Evolution	Yukon
Gamut	Major

### > Contents by effect

WOOD - Legno  
MARBLE - Marmo  
STONE - Pietra  
CONCRETE - Cemento

### > Color Index

Color Index Major 20mm

## Metis

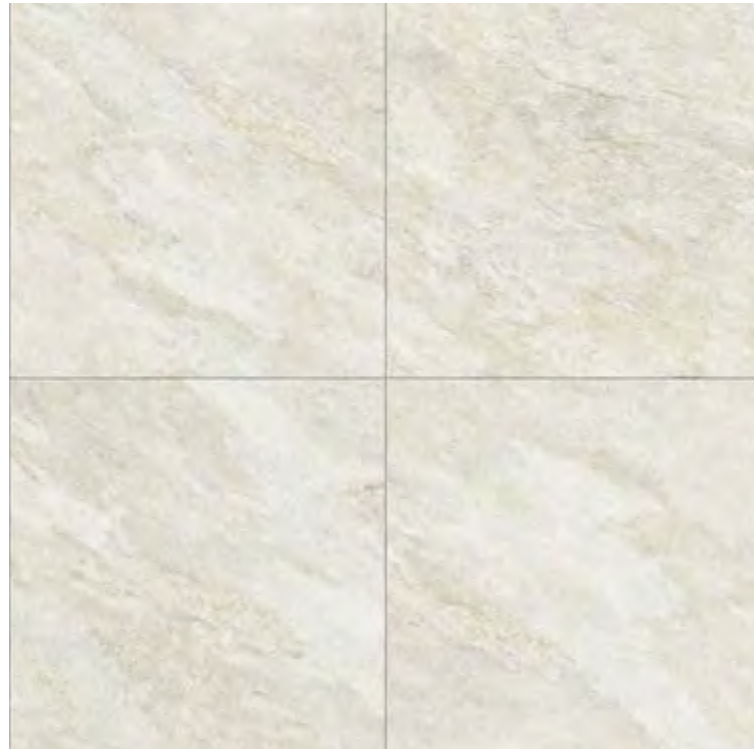

SUPERFICIE NATURALE / BORDO RETTIFICATO		A+B R10	
60x120 - 24"x47"	9	136588	93
60x60 - 24"x24"	9	137180	69

SUPERFICIE GRIP / BORDO NATURALE		A+B+C R11	
60x120 - 24"x47"	9	137888	93

## Ceres

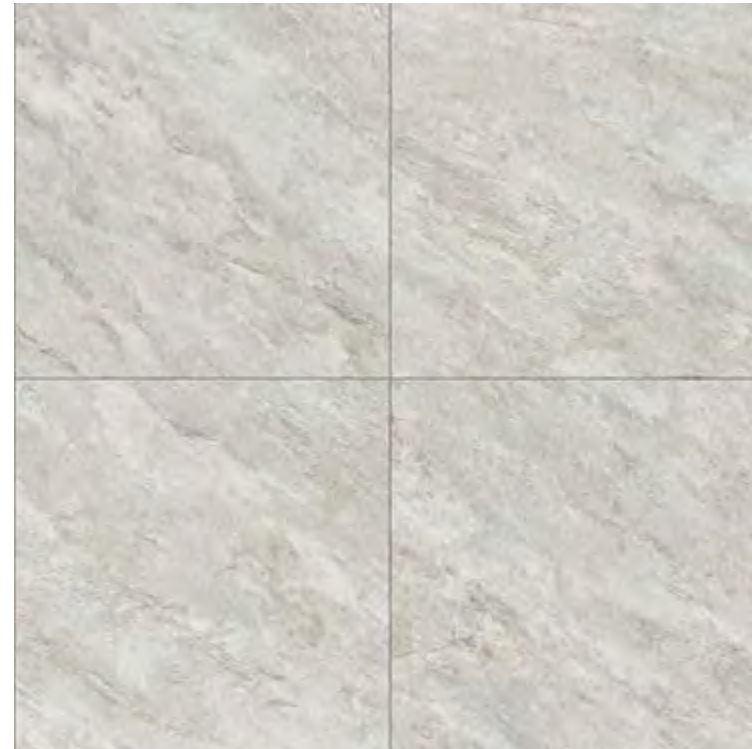

SUPERFICIE NATURALE / BORDO RETTIFICATO		A+B R10	
60x120 - 24"x47"	9	136587	93
60x60 - 24"x24"	9	137179	69

SUPERFICIE GRIP / BORDO NATURALE		A+B+C R11	
60x120 - 24"x47"	9	137890	93

## Ariel

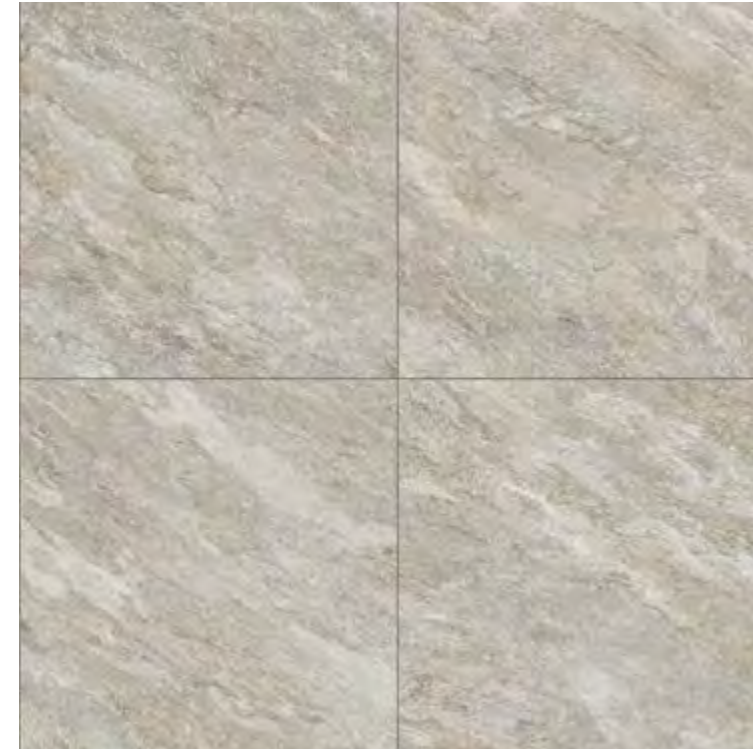

SUPERFICIE NATURALE / BORDO RETTIFICATO		A+B R10	
60x120 - 24"x47"	9	136583	93
60x60 - 24"x24"	9	137175	69

SUPERFICIE GRIP / BORDO NATURALE		A+B+C R11	
60x120 - 24"x47"	9	137887	93

## Eris



SUPERFICIE NATURALE / BORDO RETTIFICATO		A+B R10	
60x120 - 24"x47"	9	136585	93
60x60 - 24"x24"	9	137177	69

SUPERFICIE GRIP / BORDO NATURALE		A+B+C R11	
60x120 - 24"x47"	9	137889	93

# Index

- The Company
- Technology
- Sizes
- Thicknesses
- Surfaces
- Porcelain stoneware
- Ecologycare
- Certifications
- Quality and Safety
- Ceramic of Italy
- Fincibec Group
- Campus
- Engineering
- Pools & Wellness
- Facades
- Raised Flooring
- Technical Specifications

## > Contents by collection

- |              |                 |
|--------------|-----------------|
| Archè        | Geobrick        |
| Ashley       | Graphis         |
| Azimuth      | On Stage        |
| Blade        | Pietra Castello |
| Charisma     | Pietre Naturali |
| <b>Dicta</b> | Tradition       |
| Dolomite     | Transalp        |
| Esprit       | Woodtime        |
| Evolution    | Yukon           |
| Gamut        | Major           |

## > Contents by effect

- WOOD - Legno
- MARBLE - Marmo
- STONE - Pietra
- CONCRETE - Cemento

## > Color Index

Color Index Major 20mm

## Thebe

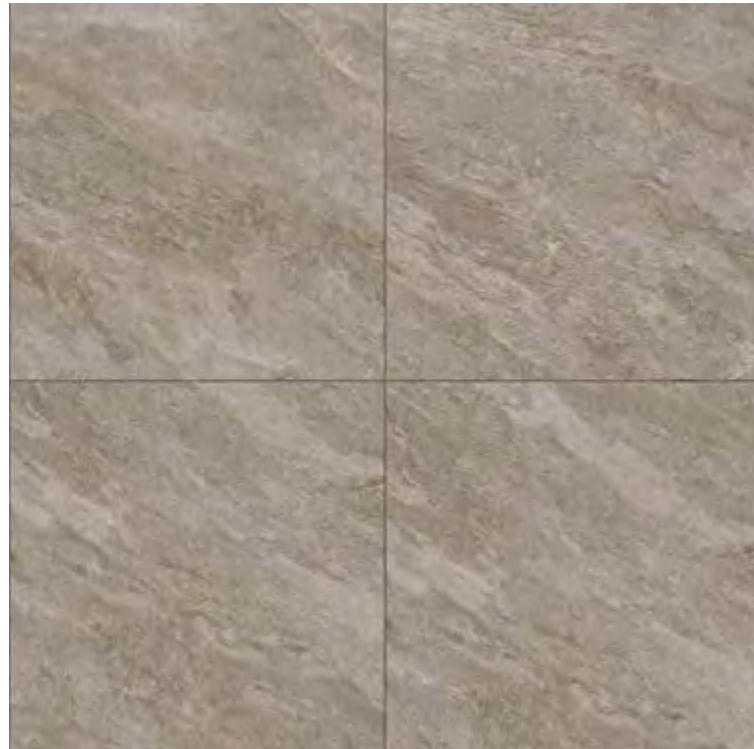

**SUPERFICIE NATURALE / BORDO RETTIFICATO** **A+B R10**

60x120 - 24"x47"	9	136584	93
60x60 - 24"x24"	9	137176	69

## Rhea

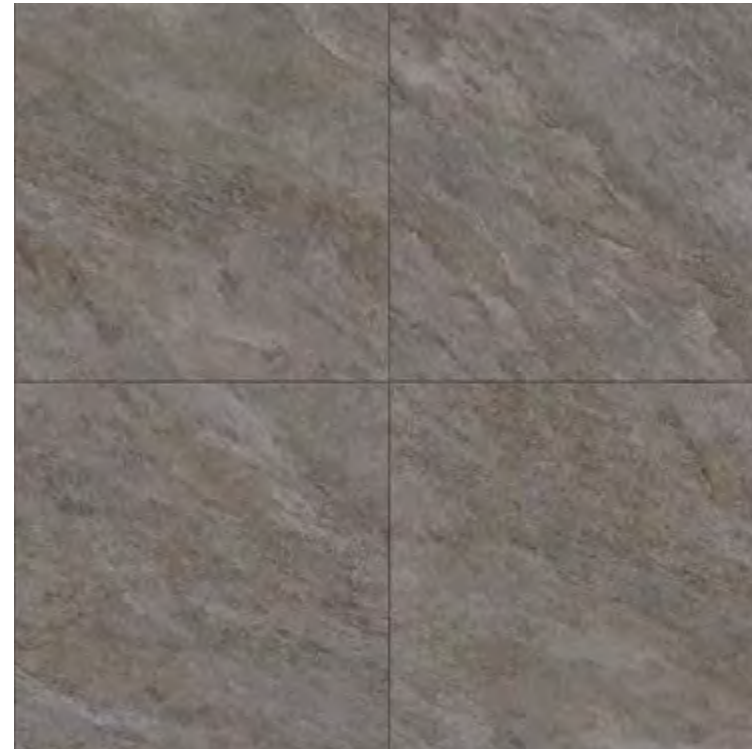

**SUPERFICIE NATURALE / BORDO RETTIFICATO** **A+B R10**

60x120 - 24"x47"	9	136586	93
60x60 - 24"x24"	9	137178	69

## Decors - Decorì - Eléments décoratifs - Dekore - Decoraciones



**SUPERFICIE NATURALE / BORDO RETTIFICATO**

ARIEL SELECT 60x120 - 24"x47"	9	137955	143
-------------------------------	---	--------	-----

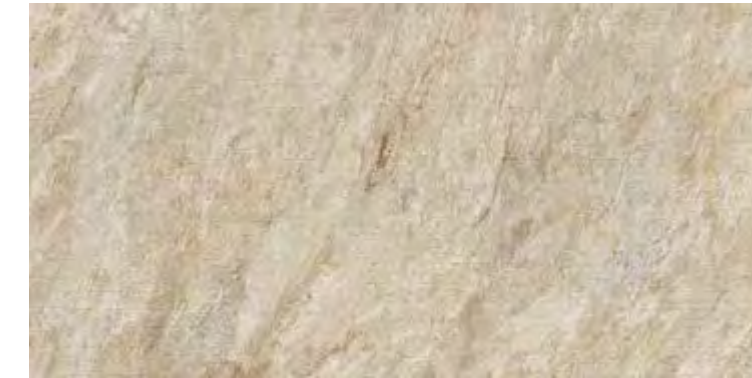

**SUPERFICIE NATURALE / BORDO RETTIFICATO**

ERIS SELECT 60x120 - 24"x47"	9	137958	143
------------------------------	---	--------	-----

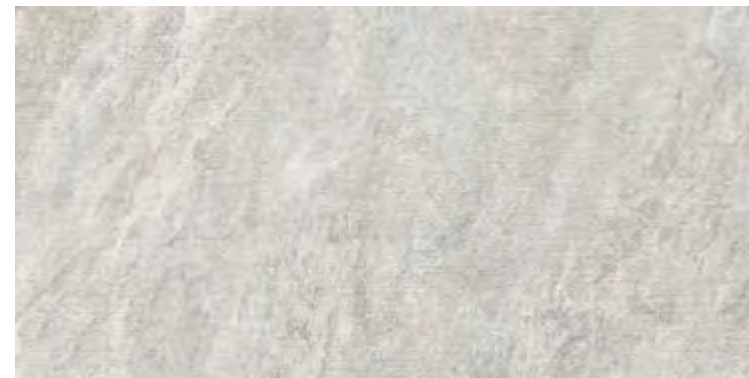

**SUPERFICIE NATURALE / BORDO RETTIFICATO**

CERES SELECT 60x120 - 24"x47"	9	137957	143
-------------------------------	---	--------	-----

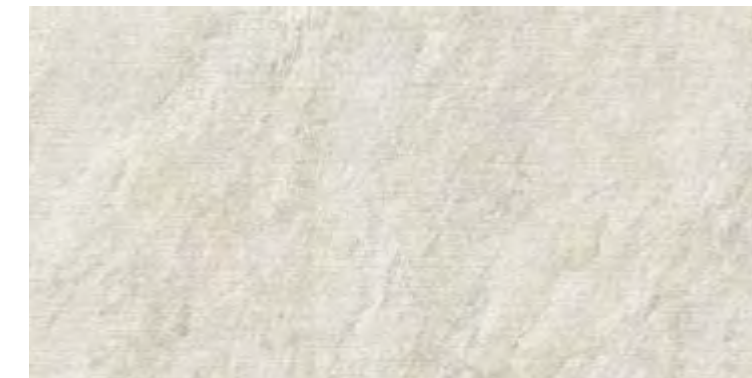

**SUPERFICIE NATURALE / BORDO RETTIFICATO**

METIS SELECT 60x120 - 24"x47"	9	137956	143
-------------------------------	---	--------	-----

 **Tiles for walls**  
Piastrille per rivestimento pareti  
Carreaux de revêtement  
Wandverkleidung Fliesen  
Azulejos para revestimiento

# Index

- The Company
- Technology
- Sizes
- Thicknesses
- Surfaces
- Porcelain stoneware
- Ecologycare
- Certifications
- Quality and Safety
- Ceramic of Italy
- Fincibec Group
- Campus
- Engineering
- Pools & Wellness
- Facades
- Raised Flooring
- Technical Specifications

## > Contents by collection

- |              |                 |
|--------------|-----------------|
| Archè        | Geobrick        |
| Ashley       | Graphis         |
| Azimuth      | On Stage        |
| Blade        | Pietra Castello |
| Charisma     | Pietre Naturali |
| <b>Dicta</b> | Tradition       |
| Dolomite     | Transalp        |
| Esprit       | Woodtime        |
| Evolution    | Yukon           |
| Gamut        | Major           |

## > Contents by effect

- WOOD - Legno
- MARBLE - Marmo
- STONE - Pietra
- CONCRETE - Cemento

## > Color Index

Color Index Major 20mm

## Decors - Decori - Eléments décoratifs - Dekore - Decoraciones

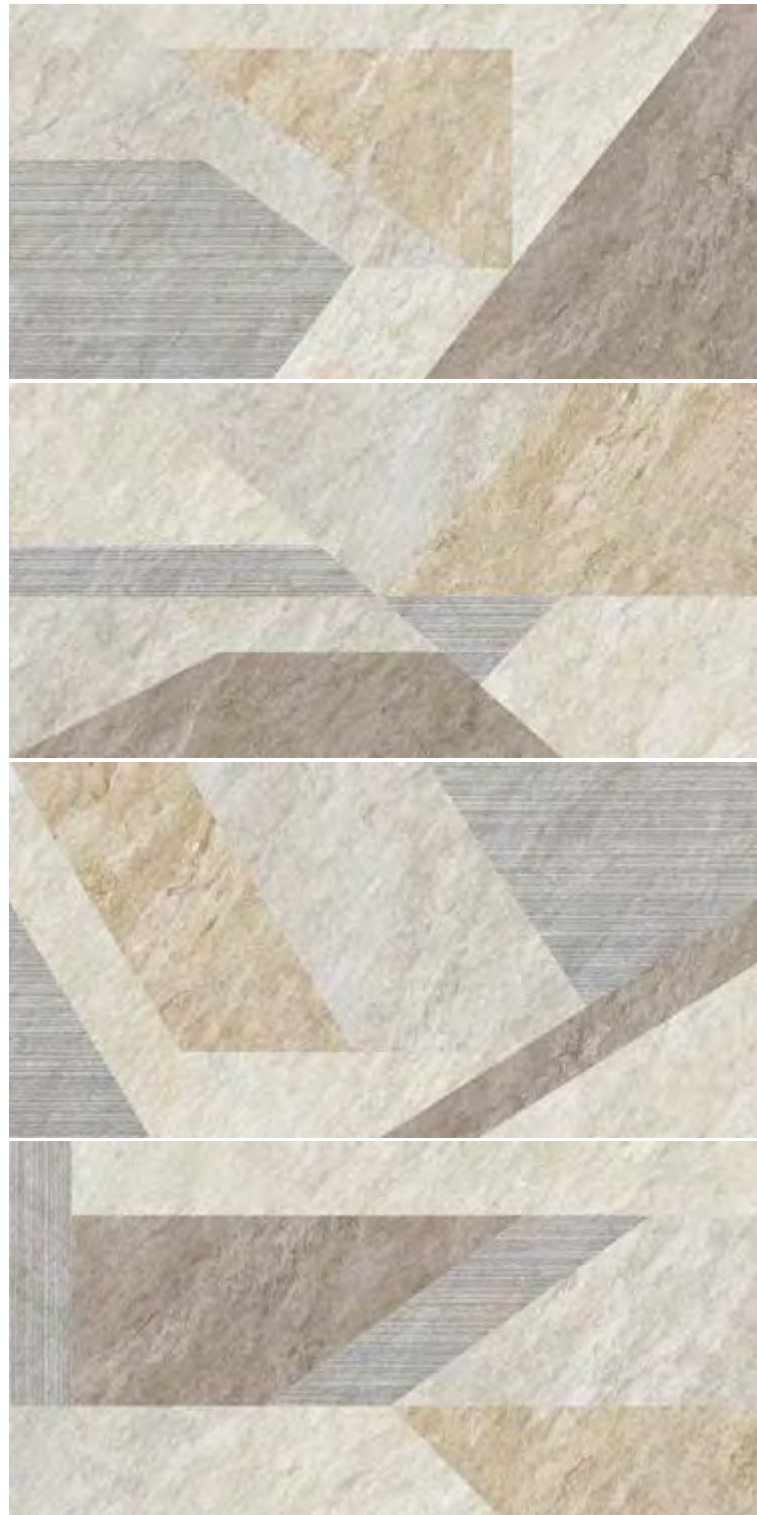

**SUPERFICIE NATURALE / BORDO RETTIFICATO** **A+B R10**  
\* GEOMETRY 60x120 - 24"x47" 9 137886 143

## Mosaics - Mosaici - Mosaïques - Mosaik - Mosaicos

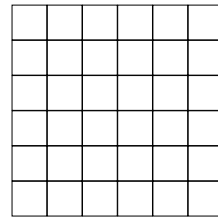

**SUPERFICIE NATURALE** **A+B**

**MOSAICO 4,7x4,7 - 1,8"x1,8" SU RETE 30x30 - 12"x12"**

ARIEL		9	137519		253
ERIS		9	137521		253
RHEA		9	137522		253
THEBE		9	137520		253
METIS		9	137524		253
CERES		9	137523		253

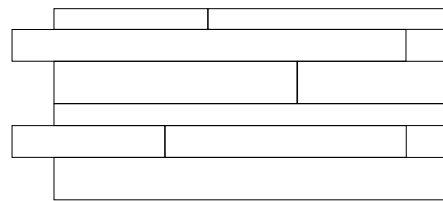

**SUPERFICIE NATURALE** **A+B**

**MURETTO SU RETE 30x60 - 12"x24"**

ARIEL		9	138081		233
ERIS		9	138083		233
RHEA		9	138084		233
THEBE		9	138082		233
METIS		9	138086		233
CERES		9	138085		233

\*Decors version with multiple subjects, packaged randomly (Matchable with all colours)

Versione decoro con più soggetti, confezionati random (Abbinabili a tutti i colori)

Version décoration avec plusieurs motifs, emballés de manière aléatoire (pouvant être assortis à toutes les couleurs)

Dekorierte Ausführung mit mehreren Darstellungen, zufällige Zusammenstellung (kann mit allen Farben kombiniert werden)

Versión decoración con varios temas, empaquetados de modo aleatorio (se puede combinar con todos los colores)

## Special pieces - Pezzi speciali - Pièces spéciales - Formstücke - Piezas especiales

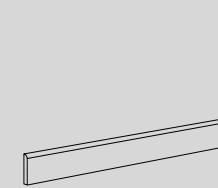

**BATTISCOPA 5,4x60 - 2"x24"**  
NATURALE RETT. 10

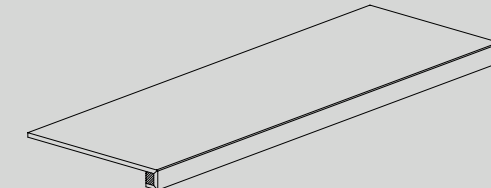

**GRADONE COSTA RETTA 33x120 - 13"x47"**  
NATURALE RETT. 333

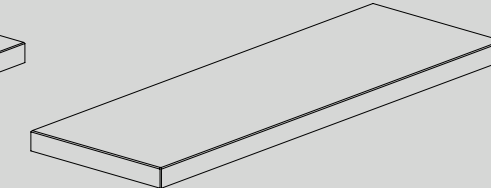

**GRADONE ANGOLARE COSTA RETTA DX/SX 33x120 - 13"x47"**  
NATURALE RETT. 345

## Packaging - Imballi - Emballages - Verpackung - Embalajes

### FLOOR TILES / PAVIMENTI / PAVIMENTS / GRUNDFLESEN / AZULEJOS

	sizes formati formats Formate formatos	60x120 24"x47"	60x60 24"x24"	30x60 12"x24" muretto	30x30 4,7x4,7 12"x12" 1,8"x1,8" mosaico
boxes colli boîtes Kartons cajas	pc.	2	3	6	11
	m <sup>2</sup>	1,44	1,08	1,08	1,0
	kg	31	21,04	23	20,3
pallets palette Paletts paletas	colli	35	40	30	36
	m <sup>2</sup>	50,4	43,2	32,4	36
	kg	1085	841,6	690	730,8

### SPECIAL PIECES / PEZZI SPECIALI / PIÈCES SPÉCIALES / FORMSTÜCKE / PIEZAS ESPECIALES

	sizes formati formats Formate formatos	5,4x60 2"x24" battiscopa	33x120 13"x47" gradone costa retta	33x120 13"x47" gradone angolare costa retta
boxes colli boîtes Kartons cajas	pc.	14	1	1
	ml	8,4	1,2	1,2
	kg	11	11,15	11,7

## Slip - Scivolosità - Glissance - Rutschwert - Adherencia

	Standard Norma Standard   Norm   Norme   Norme	Natural Surface Superficie Natural   Surface Naturelle Natur Oberflächen   Superficie Natural	Grip Surface Superficie Grip   Surface Grip Grip Oberflächen   Superficie Grip
	B.C.R.A. (D.M.I. n. 236 μ>0,4)	> 0,40	> 0,40
	ANSI A 326.3 (DCOF WET >0,42)	> 0,42	> 0,42
	DIN EN 16165 ANNEX B	R10	R11
	DIN EN 16165 ANNEX A	A+B A+B MOSAICO 4,7x4,7	A+B+C

- The Company
- Technology
- Sizes
- Thicknesses
- Surfaces
- Porcelain stoneware
- Ecologycare
- Certifications
- Quality and Safety
- Ceramic of Italy
- Fincibec Group
- Campus
- Engineering
- Pools & Wellness
- Facades
- Raised Flooring
- Technical Specifications

## Contents by collection

- |              |                 |
|--------------|-----------------|
| Archè        | Geobrick        |
| Ashley       | Graphis         |
| Azimuth      | On Stage        |
| Blade        | Pietra Castello |
| Charisma     | Pietre Naturali |
| <b>Dicta</b> | Tradition       |
| Dolomite     | Transalp        |
| Esprit       | Woodtime        |
| Evolution    | Yukon           |
| Gamut        | Major           |

## Contents by effect

- WOOD - Legno
- MARBLE - Marmo
- STONE - Pietra
- CONCRETE - Cemento

## Color Index

Color Index Major 20mm

# Archè

Fine porcelain stoneware - Gres fine porcellanato  
Grès cérame fin - Feinsteinzeug - Gres fine porcelánico

download  
catalogue



watch  
the video



Colours - Colori  
Couleurs - Farben - Colores

Acqua

Logos

Etere

Terra

Apeiron

**V2** Light variation - Lieve variazione  
Variation légère  
Gerinde Farbunterschied  
Variación escasa

Sizes - Formati  
Formats - Formaten - Formatos

120x120 cm  
60x120 cm  
60x60 cm  
50x50 cm  
25x50 cm  
25x25 cm

Thicknesses - Spessori  
Epaisseurs - Dicken - Espesores

7 mm  
10 mm

Surfaces - Superfici  
Surfaces - Oberflächen - Superficies

Natural - Naturale  
Naturelle - Natur - Natural

Grip

Edges - Bordi  
Bordes - Kanten - Bordes

Natural - Naturale  
Naturelle - Natur - Natural

Rectified - Rettificato  
Rectifié - Rektifiziert - Rectificado

**F**  
20mm **MAJOR**  
50x100 cm  
PAG. 183

ISO 13006 Bla - EN 14411/G  
Fully-resistant flooring  
Pavimenti a resistenza totale  
Sols à résistance totale - Absolut widerständige  
Fußböden - Pavimentos de resistencia total



**c4** Floor tiles recommended for medium traffic areas.  
Piastrille da pavimento consigliate per calpestio medio.  
Carreaux de sol recommandés pour un trafic piétonnier moyen.  
Bodenfliesen, empfohlen für mittlere Beanspruchung.  
Baldosas de suelo recomendadas para el tránsito medio.

**c5** Floor tiles recommended for heavy uses.  
Piastrille da pavimento consigliate per calpestio intenso.  
Carreaux de sol recommandés pour un trafic piétonnier intense.  
Bodenfliesen, empfohlen für intensive Beanspruchung.  
Baldosas de suelo recomendadas para tránsito intenso.

stone effect - effetto pietra - effet pierre - Steineffekt - efecto piedra

## Index

- The Company
- Technology
- Sizes
- Thicknesses
- Surfaces
- Porcelain stoneware
- Ecologycare
- Certifications
- Quality and Safety
- Ceramic of Italy
- Fincibec Group
- Campus
- Engineering
- Pools & Wellness
- Facades
- Raised Flooring
- Technical Specifications

### Contents by collection

- |           |                 |
|-----------|-----------------|
| Archè     | Geobrick        |
| Ashley    | Graphis         |
| Azimuth   | On Stage        |
| Blade     | Pietra Castello |
| Charisma  | Pietre Naturali |
| Dicta     | Tradition       |
| Dolomite  | Transalp        |
| Esprit    | Woodtime        |
| Evolution | Yukon           |
| Gamut     | Major           |

### Contents by effect

- WOOD - Legno
- MARBLE - Marmo
- STONE - Pietra
- CONCRETE - Cemento

### Color Index

Color Index Major 20mm

- The Company
- Technology
- Sizes
- Thicknesses
- Surfaces
- Porcelain stoneware
- Ecologycare
- Certifications
- Quality and Safety
- Ceramic of Italy
- Fincibec Group
- Campus
- Engineering
- Pools & Wellness
- Facades
- Raised Flooring
- Technical Specifications

### > Contents by collection

- |           |                 |
|-----------|-----------------|
| Archè     | Geobrick        |
| Ashley    | Graphis         |
| Azimuth   | On Stage        |
| Blade     | Pietra Castello |
| Charisma  | Pietre Naturali |
| Dicta     | Tradition       |
| Dolomite  | Transalp        |
| Esprit    | Woodtime        |
| Evolution | Yukon           |
| Gamut     | Major           |

### > Contents by effect

- WOOD - Legno
- MARBLE - Marmo
- STONE - Pietra
- CONCRETE - Cemento

### > Color Index

Color Index Major 20mm

## Acqua



SUPERFICIE NATURALE / BORDO RETTIFICATO		A+B R10	
▲ 120x120 - 47"x47"	7	133549	127
60x120 - 24"x47"	7	133351	93
60x60 - 24"x24"	7	133357	69

## Logos



SUPERFICIE NATURALE / BORDO RETTIFICATO		A+B R10	
▲ 120x120 - 47"x47"	7	133552	127
60x120 - 24"x47"	7	133354	93
60x60 - 24"x24"	7	133360	69

SUPERFICIE GRIP / BORDO NATURALE		A+B+C R11	
50x50 - 20"x20"	10	133837	63
25x50 - 10"x20"	10	133839	63
25x25 - 10"x10"	10	133843	63

## Etere



SUPERFICIE NATURALE / BORDO RETTIFICATO		A+B R10	
▲ 120x120 - 47"x47"	7	133553	127
60x120 - 24"x47"	7	133355	93
60x60 - 24"x24"	7	133361	69

SUPERFICIE GRIP / BORDO NATURALE		A+B+C R11	
50x50 - 20"x20"	10	133838	63
25x50 - 10"x20"	10	133840	63
25x25 - 10"x10"	10	133844	63

## Terra

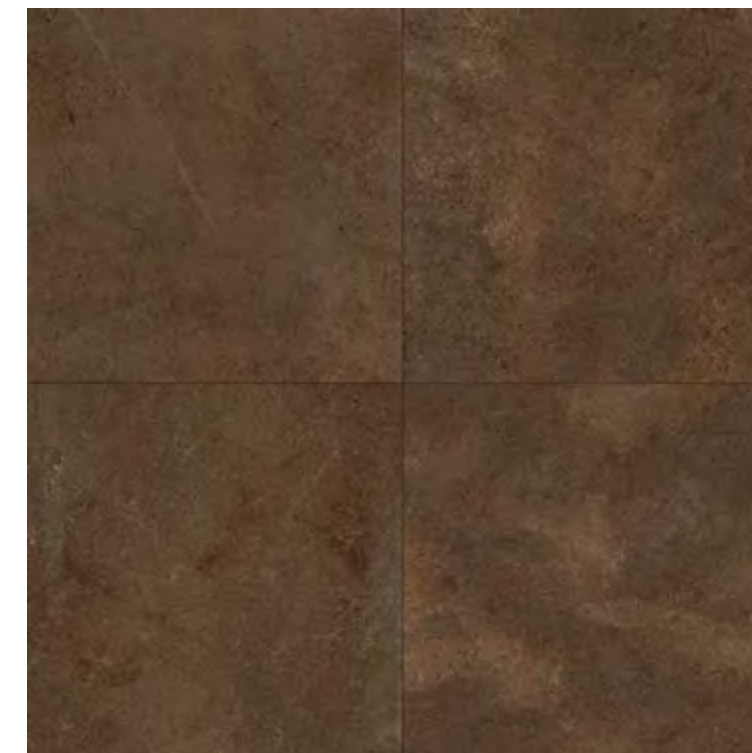

SUPERFICIE NATURALE / BORDO RETTIFICATO		A+B R10	
▲ 120x120 - 47"x47"	7	133551	127
60x120 - 24"x47"	7	133353	93
60x60 - 24"x24"	7	133359	69

▲ cm 120x120 split pallet surcharge 40 € each - lightened stand containing 95 €  
cm 120x120 addebito frazione di paletta 40 € - cavalla alleggerita 95 €  
cm 120x120 surtaxe contremarque 40 € - chevalet allégé 95 €  
cm 120x120 Aufpreis Teilpalette 40 € - leichter Ständer 95 €  
cm 120x120 recargo fracción de paleta 40 € - soporte ligero 95 €

▲ cm 120x120 split pallet surcharge 40 € each - lightened stand containing 95 €  
cm 120x120 addebito frazione di paletta 40 € - cavalla alleggerita 95 €  
cm 120x120 surtaxe contremarque 40 € - chevalet allégé 95 €  
cm 120x120 Aufpreis Teilpalette 40 € - leichter Ständer 95 €  
cm 120x120 recargo fracción de paleta 40 € - soporte ligero 95 €

## Apeiron



SUPERFICIE NATURALE / BORDO RETTIFICATO		A+B R10	
▲ 120x120 - 47"x47"	7	133550	127
60x120 - 24"x47"	7	133352	93
60x60 - 24"x24"	7	133358	69

▲ cm 120x120 split pallet surcharge 40 € each - lightened stand containing 95 €  
 cm 120x120 addebito frazione di paletta 40 € - cavalla alleggerita 95 €  
 cm 120x120 surtaxe contremarque 40 € - chevalet allégé 95 €  
 cm 120x120 Aufpreis Teilpalette 40 € - leichter Ständer 95 €  
 cm 120x120 recargo fracción de paleta 40 € - soporte ligero 95 €

Fine porcelain stoneware - Gres fine porcellanato  
 Grès cérame fin - Feinsteinzeug - Gres fine porcelánico

## Decors - Decori - Eléments décoratifs - Dekore - Decoraciones



SUPERFICIE NATURALE / BORDO RETTIFICATO		A+B R10	
* FABULA 60x120 - 24"x47"	7	133356	143

\*Decors version with multiple subjects, packaged randomly  
 (Matchable with all colours)

Versione decoro con più soggetti, confezionati random  
 (Abbinabili a tutti i colori)

Version décoration avec plusieurs motifs, emballés de manière  
 aléatoire (pouvant être assortis à toutes les couleurs)

Dekorierter Ausführung mit mehreren Darstellungen, zufällige  
 Zusammenstellung (kann mit allen Farben kombiniert werden)

Versión decoración con varios temas, empaquetados de modo  
 aleatorio (se puede combinar con todos los colores)

stone effect - effetto pietra - effet pierre - Steineffekt - efecto piedra

## Mosaics - Mosaici - Mosaïques - Mosaik - Mosaicos

SUPERFICIE NATURALE		A+B	
MOSAICO 4,7x4,7 - 1,8"x1,8" SU RETE 30x30 - 12"x12"			
ACQUA	7	133541	253
LOGOS	7	133544	253
ETERE	7	133545	253
TERRA	7	133543	253
APEIRON	7	133542	253

## Special pieces - Pezzi speciali - Pièces spéciales - Formstücke - Piezas especiales

<b>BATTISCOPA 5,4x60 - 2"x24"</b> NATURALE RETT. ● 10	<b>BATTISCOPA 8x50 - 3"x20"</b> GRIP ● 8	<b>GRADONE COSTA RETTA 120x33 - 47"x13"</b> NATURALE RETT. ● 333	<b>GRADONE ANGOLARE COSTA RETTA DX/SX 120x33 - 47"x13"</b> NATURALE RETT. ● 345
<b>GRADINO 25x50 - 10"x20"</b> GRIP ● 28	<b>ELEMENTO ELLE MONOLITICO 15x30x4 - 6"x12" x1,5"</b> GRIP ● 22		

Minimum order 5 pieces / Ordine minimo 5 pz / Commande minimum 5 pièces / Mindestbestellmenge 5 Stück / Pedido mínimo 5 piezas

## Packaging - Imballi - Emballages - Verpackung - Embalajes

FLOOR TILES / PAVIMENTI / PAVIMENTS / GRUNDFLIESEN / AZULEJOS		120x120 47"x47"	60x120 24"x47"	60x60 24"x24"	50x50 20"x20"	25x50 10"x20"	25x25 10"x10"	30x30 4,7x4,7 12"x12" 1,8"x1,8" mosaico
	boxes colli boîtes Kartons cajas	2	3	4	4	9	17	11
	pc.	2,88	2,16	1,44	1,00	1,13	1,06	1,0
	m <sup>2</sup>	50,2	35,67	23	21,5	23,5	22,8	16,3
	kg							
	pallets pallet palette Paletts paletas	26	30	40	36	54	57	-
	colli	74,88	64,8	57,6	36	60,75	60,591	-
	m <sup>2</sup>	1305,2	1070	920	774	1269	1299,6	-
	kg							

SPECIAL PIECES / PEZZI SPECIALI / PIÈCES SPÉCIALES / FORMSTÜCKE / PIEZAS ESPECIALES		5,4x60 2"x24" battiscopa	8x50 3"x20" battiscopa	15x30x4 6"x12" x1,5" elemento elle monolitico	25x50 10"x20" gradino	33x120 13"x47" gradone costa retta	33x120 13"x47" gradone angolare costa retta
	boxes colli boîtes Kartons cajas	14	20	6	6	1	1
	pc.	8,4	10	1,8	3	1,2	1,2
	ml	11,0	22,5	8,1	15,6	11,2	11,7
	kg						

## Slip - Scivolosità - Glisance - Rutschwert - Adherencia

	Standard Norma Standard   Norm   Norme   Norme	Natural Surface Superficie Natural   Surface Naturelle Natur Oberflächen   Superficie Natural	Grip Surface Superficie Grip   Surface Grip Grip Oberflächen   Superficie Grip
	B.C.R.A. (D.M.I. n. 236 μ>0,4)	> 0,40	> 0,40
	ANSI A 326.3 (DCOF WET >0,42)	> 0,42	> 0,42
	DIN EN 16165 ANNEX B	R10	R11
	DIN EN 16165 ANNEX A	A+B A+B MOSAICO 4,7x4,7	A+B+C
	BS EN 16165 ANNEX C	-	≥ 36 Dry / ≥ 36 Wet
	AS 4586	-	Class P4

- The Company
- Technology
- Sizes
- Thicknesses
- Surfaces
- Porcelain stoneware
- Ecologycare
- Certifications
- Quality and Safety
- Ceramic of Italy
- Fincibec Group
- Campus
- Engineering
- Pools & Wellness
- Facades
- Raised Flooring
- Technical Specifications

## Contents by collection

- Archè
- Ashley
- Azimuth
- Blade
- Charisma
- Dicta
- Dolomite
- Esprit
- Evolution
- Gamut
- Geobrick
- Graphis
- On Stage
- Pietra Castello
- Pietre Naturali
- Tradition
- Transalp
- Woodtime
- Yukon
- Major

## Contents by effect

- WOOD - Legno
- MARBLE - Marmo
- STONE - Pietra
- CONCRETE - Cemento

## Color Index

Color Index Major 20mm

# Azimuth

Fine porcelain stoneware - Gres fine porcellanato  
Grès cérame fin - Feinsteinzeug - Gres fine porcelánico

download  
catalogue

watch  
the video



Colours - Colori  
Couleurs - Farben - Cores

Gravity

Meridian

Time

Vector

Alpha

V2 Light variation - Lieve variazione  
Variation légère  
Gerinde Farbunterschied  
Variación escasa

Sizes - Formati  
Formats - Formaten - Formatos

120x278 cm  
120x120 cm  
60x120 cm  
60x60 cm

Thicknesses - Spessori  
Epaisseurs - Dicken - Espesores

7 mm  
9 mm

Surfaces - Superfici  
Surfaces - Oberflächen - Superficies

Natural - Naturale  
Naturelle - Natur - Natural

Brushed - Molata  
Adouci - Geschliffen - Molida

Grip

Edges - Bordi  
Bordes - Kanten - Bordes

Rectified - Rettificato  
Rectifié - Rektifiziert - Rectificado

ISO 13006 Bla - EN 14411/G  
Fully-resistant flooring  
Pavimenti a resistenza totale  
Sols à résistance totale - Absolut widerständige  
Fußböden - Pavimentos de resistencia total



c4 Floor tiles recommended for medium traffic areas.  
Piastrille da pavimento consigliate per calpestio medio.  
Carreaux de sol recommandés pour un trafic piétonnier moyen.  
Bodenfliesen, empfohlen für mittlere Beanspruchung.  
Baldosas de suelo recomendadas para el tránsito medio.

c5 Floor tiles recommended for heavy uses.  
Piastrille da pavimento consigliate per calpestio intenso.  
Carreaux de sol recommandés pour un trafic piétonnier intense.  
Bodenfliesen, empfohlen für intensive Beanspruchung.  
Baldosas de suelo recomendadas para tránsito intenso.

stone effect - effetto pietra - effet pierre - Steineffekt - efecto piedra

## Index

The Company  
Technology  
Sizes  
Thicknesses  
Surfaces  
Porcelain stoneware  
Ecologycare  
Certifications  
Quality and Safety  
Ceramic of Italy  
Fincibec Group  
Campus  
Engineering  
Pools & Wellness  
Facades  
Raised Flooring  
Technical Specifications

### Contents by collection

Archè	Geobrick
Ashley	Graphis
<b>Azimuth</b>	On Stage
Blade	Pietra Castello
Charisma	Pietre Naturali
Dicta	Tradition
Dolomite	Transalp
Esprit	Woodtime
Evolution	Yukon
Gamut	Major

### Contents by effect

WOOD - Legno  
MARBLE - Marmo  
STONE - Pietra  
CONCRETE - Cemento

### Color Index

Color Index Major 20mm



- The Company
- Technology
- Sizes
- Thicknesses
- Surfaces
- Porcelain stoneware
- Ecologycare
- Certifications
- Quality and Safety
- Ceramic of Italy
- Fincibec Group
- Campus
- Engineering
- Pools & Wellness
- Facades
- Raised Flooring
- Technical Specifications

## ➤ Contents by collection

- |                |                 |
|----------------|-----------------|
| Archè          | Geobrick        |
| Ashley         | Graphis         |
| <b>Azimuth</b> | On Stage        |
| Blade          | Pietra Castello |
| Charisma       | Pietre Naturali |
| Dicta          | Tradition       |
| Dolomite       | Transalp        |
| Esprit         | Woodtime        |
| Evolution      | Yukon           |
| Gamut          | Major           |

## ➤ Contents by effect

- WOOD - Legno
- MARBLE - Marmo
- STONE - Pietra
- CONCRETE - Cemento

## ➤ Color Index

Color Index Major 20mm

## Gravity

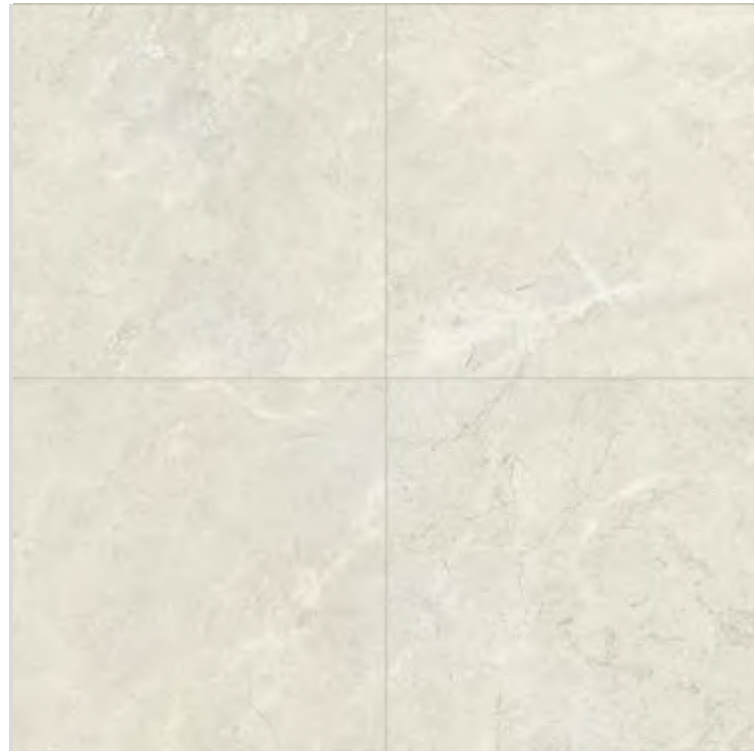

SUPERFICIE NATURALE / BORDO RETTIFICATO		A+B R10	
▲ 120x120 - 47"x47"	I 9	133015	■ 127
60x120 - 24"x47"	I 9	133274	■ 93
60x60 - 24"x24"	I 9	133759	■ 69

SUPERFICIE MOLATA / BORDO RETTIFICATO			
▲ 120x120 - 47"x47"	I 9	133020	■ 163
60x120 - 24"x47"	I 9	133279	■ 109
60x60 - 24"x24"	I 9	133766	■ 83

SUPERFICIE GRIP / BORDO RETTIFICATO		A+B+C R11	
60x120 - 24"x47"	I 9	133754	■ 93

▲ cm 120x278 pallet surcharge 140 € - stand containing 295 €  
cm 120x278 addebito cassa 140 € - cavalla 295 €  
cm 120x278 surtaxe caisse 140 € - chevalet 295 €  
cm 120x278 Aufpreis Kiste 140 € - Ständer 295 €  
cm 120x278 recargo caja 140 € - soporte 295 €

▲ cm 120x120 split pallet surcharge 40 € each - lightened stand containing 95 €  
cm 120x120 addebito frazione di paletta 40 € - cavalla alleggerita 95 €  
cm 120x120 surtaxe contremarque 40 € - chevalet allégé 95 €  
cm 120x120 Aufpreis Teilpalette 40 € - leichter Ständer 95 €  
cm 120x120 recargo fracción de paleta 40 € - soporte ligero 95 €



SUPERFICIE MOLATA / BORDO RETTIFICATO			
▲ 120x278 - 47"x109.5"	I 7	135754	■ 213

## Vector

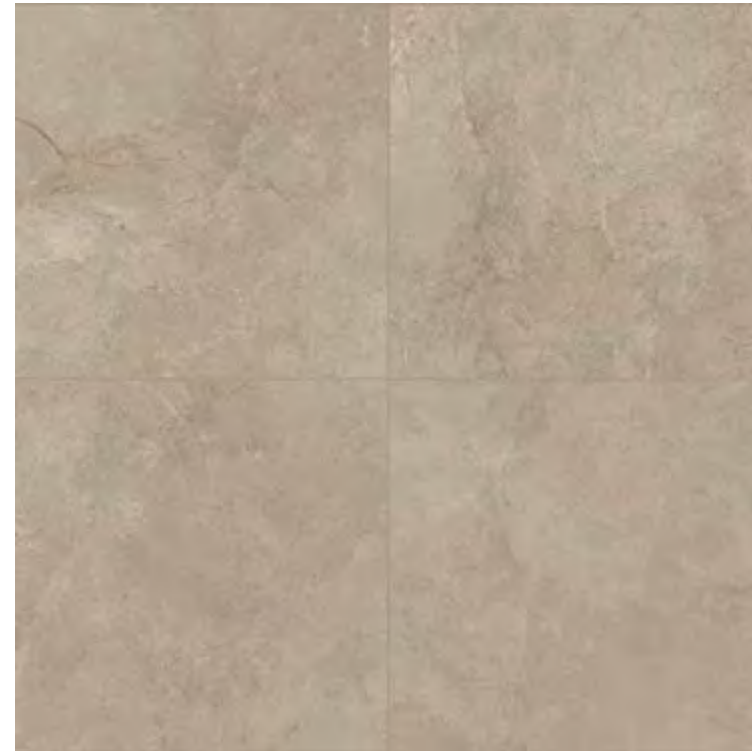

SUPERFICIE NATURALE / BORDO RETTIFICATO		A+B R10	
▲ 120x120 - 47"x47"	I 9	133014	■ 127
60x120 - 24"x47"	I 9	133277	■ 93
60x60 - 24"x24"	I 9	133763	■ 69

SUPERFICIE MOLATA / BORDO RETTIFICATO			
▲ 120x120 - 47"x47"	I 9	133019	■ 163
60x120 - 24"x47"	I 9	133282	■ 109
60x60 - 24"x24"	I 9	133770	■ 83

SUPERFICIE GRIP / BORDO RETTIFICATO		A+B+C R11	
60x120 - 24"x47"	I 9	133757	■ 93

▲ cm 120x278 pallet surcharge 140 € - stand containing 295 €  
cm 120x278 addebito cassa 140 € - cavalla 295 €  
cm 120x278 surtaxe caisse 140 € - chevalet 295 €  
cm 120x278 Aufpreis Kiste 140 € - Ständer 295 €  
cm 120x278 recargo caja 140 € - soporte 295 €

▲ cm 120x120 split pallet surcharge 40 € each - lightened stand containing 95 €  
cm 120x120 addebito frazione di paletta 40 € - cavalla alleggerita 95 €  
cm 120x120 surtaxe contremarque 40 € - chevalet allégé 95 €  
cm 120x120 Aufpreis Teilpalette 40 € - leichter Ständer 95 €  
cm 120x120 recargo fracción de paleta 40 € - soporte ligero 95 €



SUPERFICIE MOLATA / BORDO RETTIFICATO			
▲ 120x278 - 47"x109.5"	I 7	135755	■ 213

- The Company
- Technology
- Sizes
- Thicknesses
- Surfaces
- Porcelain stoneware
- Ecologycare
- Certifications
- Quality and Safety
- Ceramic of Italy
- Fincibec Group
- Campus
- Engineering
- Pools & Wellness
- Facades
- Raised Flooring
- Technical Specifications

## ➤ Contents by collection

- |                |                 |
|----------------|-----------------|
| Archè          | Geobrick        |
| Ashley         | Graphis         |
| <b>Azimuth</b> | On Stage        |
| Blade          | Pietra Castello |
| Charisma       | Pietre Naturali |
| Dicta          | Tradition       |
| Dolomite       | Transalp        |
| Esprit         | Woodtime        |
| Evolution      | Yukon           |
| Gamut          | Major           |

## ➤ Contents by effect

- WOOD - Legno
- MARBLE - Marmo
- STONE - Pietra
- CONCRETE - Cemento

## ➤ Color Index

Color Index Major 20mm

## Alpha



SUPERFICIE NATURALE / BORDO RETTIFICATO		A+B R10	
▲ 120x120 - 47"x47"	I 9	133011	■ 127
60x120 - 24"x47"	I 9	133273	■ 93
60x60 - 24"x24"	I 9	133758	■ 69

SUPERFICIE MOLATA / BORDO RETTIFICATO			
▲ 120x120 - 47"x47"	I 9	133016	■ 163
60x120 - 24"x47"	I 9	133278	■ 109
60x60 - 24"x24"	I 9	133765	■ 83

SUPERFICIE GRIP / BORDO RETTIFICATO		A+B+C R11	
60x120 - 24"x47"	I 9	133753	■ 93

▲ cm 120x278 pallet surcharge 140 € - stand containing 295 €  
 cm 120x278 addebito cassa 140 € - cavalla 295 €  
 cm 120x278 surtaxe caisse 140 € - chevalet 295 €  
 cm 120x278 Aufpreis Kiste 140 € - Ständer 295 €  
 cm 120x278 recargo caja 140 € - soporte 295 €

▲ cm 120x120 split pallet surcharge 40 € each - lightened stand containing 95 €  
 cm 120x120 addebito frazione di paletta 40 € - cavalla alleggerita 95 €  
 cm 120x120 surtaxe contremarque 40 € - chevalet allégé 95 €  
 cm 120x120 Aufpreis Teilpalette 40 € - leichter Ständer 95 €  
 cm 120x120 recargo fracción de paleta 40 € - soporte ligero 95 €

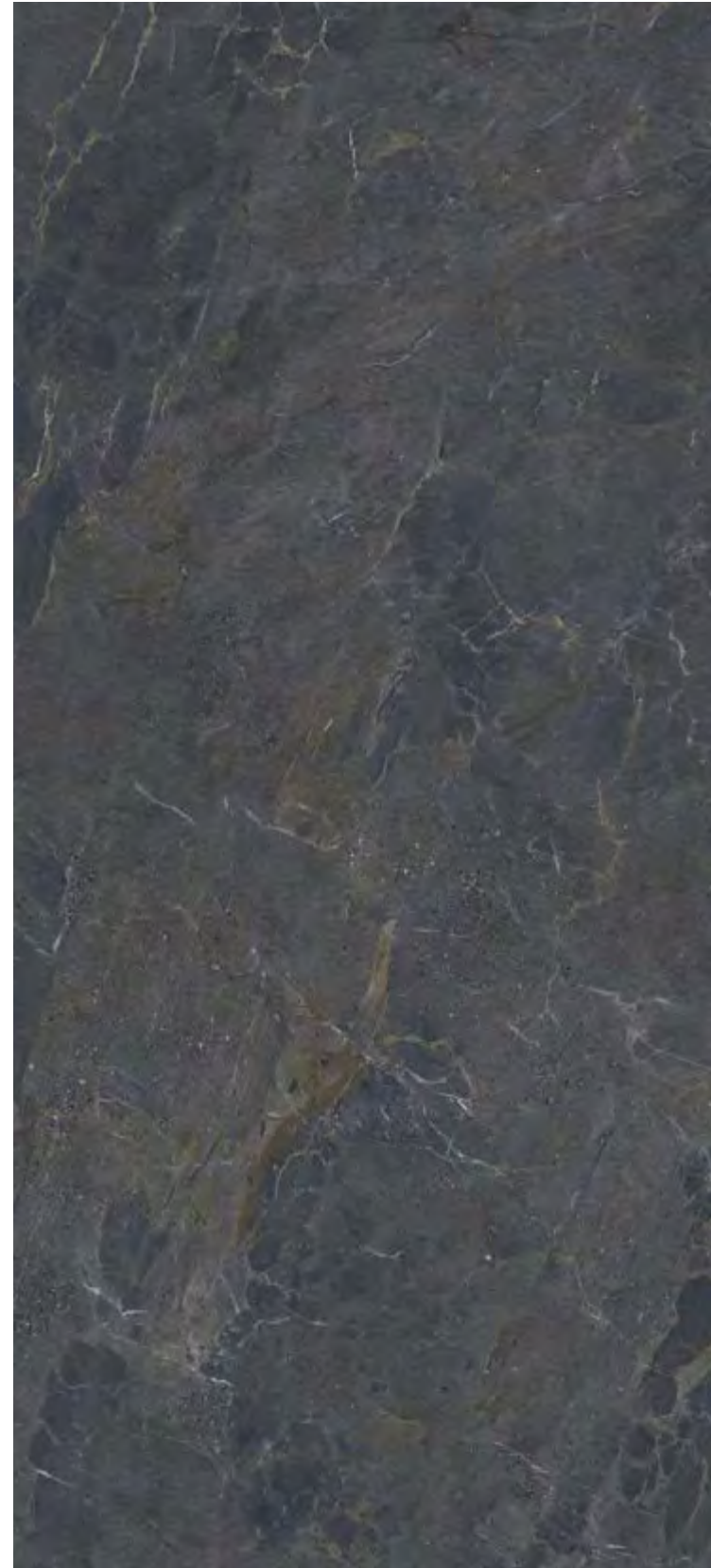

SUPERFICIE MOLATA / BORDO RETTIFICATO			
▲ 120x278 - 47"x109,5"	I 7	135753	■ 213

## Time



SUPERFICIE NATURALE / BORDO RETTIFICATO		A+B R10	
▲ 120x120 - 47"x47"	I 9	133012	■ 127
60x120 - 24"x47"	I 9	133276	■ 93
60x60 - 24"x24"	I 9	133762	■ 69

SUPERFICIE MOLATA / BORDO RETTIFICATO			
▲ 120x120 - 47"x47"	I 9	133017	■ 163
60x120 - 24"x47"	I 9	133281	■ 109
60x60 - 24"x24"	I 9	133768	■ 83

SUPERFICIE GRIP / BORDO RETTIFICATO		A+B+C R11	
60x120 - 24"x47"	I 9	133756	■ 93

## Meridian

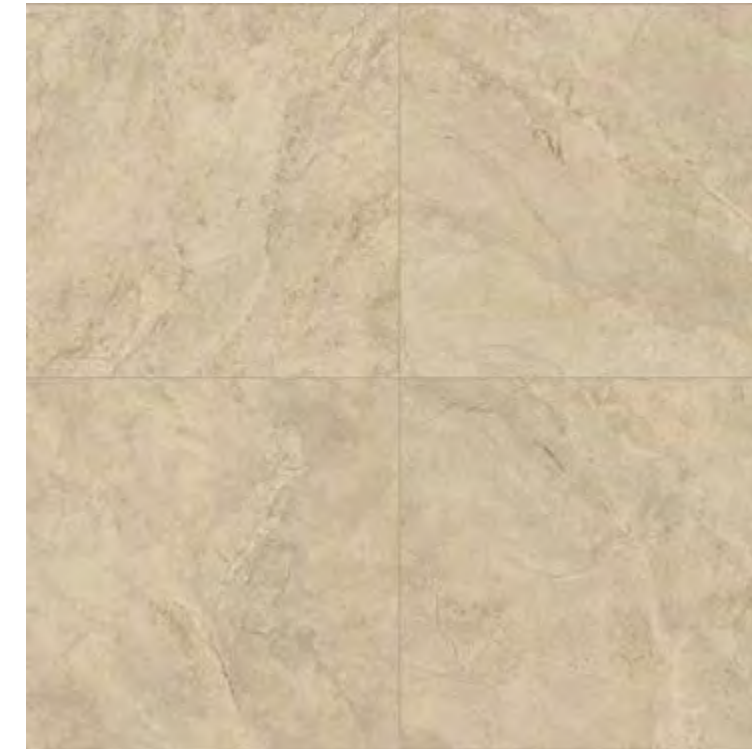

SUPERFICIE NATURALE / BORDO RETTIFICATO		A+B R10	
▲ 120x120 - 47"x47"	I 9	133013	■ 127
60x120 - 24"x47"	I 9	133275	■ 93
60x60 - 24"x24"	I 9	133761	■ 69

SUPERFICIE MOLATA / BORDO RETTIFICATO			
▲ 120x120 - 47"x47"	I 9	133018	■ 163
60x120 - 24"x47"	I 9	133280	■ 109
60x60 - 24"x24"	I 9	133767	■ 83

SUPERFICIE GRIP / BORDO RETTIFICATO		A+B+C R11	
60x120 - 24"x47"	I 9	133755	■ 93

▲ cm 120x120 split pallet surcharge 40 € each - lightened stand containing 95 €  
 cm 120x120 addebito frazione di paletta 40 € - cavalla alleggerita 95 €  
 cm 120x120 surtaxe contremarque 40 € - chevalet allégé 95 €  
 cm 120x120 Aufpreis Teilpalette 40 € - leichter Ständer 95 €  
 cm 120x120 recargo fracción de paleta 40 € - soporte ligero 95 €

Decors - Decori - Eléments décoratifs - Dekore - Decoraciones



**SUPERFICIE NATURALE / BORDO RETTIFICATO**  
GROOVE GRAVITY 30x120 - 12"x47" | 9 | 133764 | 163



**SUPERFICIE NATURALE / BORDO RETTIFICATO**  
GROOVE VECTOR 30x120 - 12"x47" | 9 | 133303 | 163



**SUPERFICIE NATURALE / BORDO RETTIFICATO**  
GROOVE ALPHA 30x120 - 12"x47" | 9 | 133301 | 163

**SUPERFICIE MOLATA / BORDO RETTIFICATO**  
▲ NATIVE 120x120 - 47"x47" | 9 | 134780 | 183



**SUPERFICIE MOLATA / BORDO RETTIFICATO**  
▲ UNISON 120x120 - 47"x47" | 9 | 134781 | 183

 **Tiles for walls**  
Piastrille per rivestimento pareti  
Carreaux de revêtement  
Wandverkleidung Fliesen  
Azulejos para revestimiento

▲ cm 120x120 split pallet surcharge 40 € each - lightened stand containing 95 €  
cm 120x120 addebito frazione di paletta 40 € - cavalla alleggerita 95 €  
cm 120x120 surtaxe contremarque 40 € - chevalet allégé 95 €  
cm 120x120 Aufpreis Teilpalette 40 € - leichter Ständer 95 €  
cm 120x120 recargo fracción de paleta 40 € - soporte ligero 95 €

Decors - Decori - Eléments décoratifs - Dekore - Decoraciones

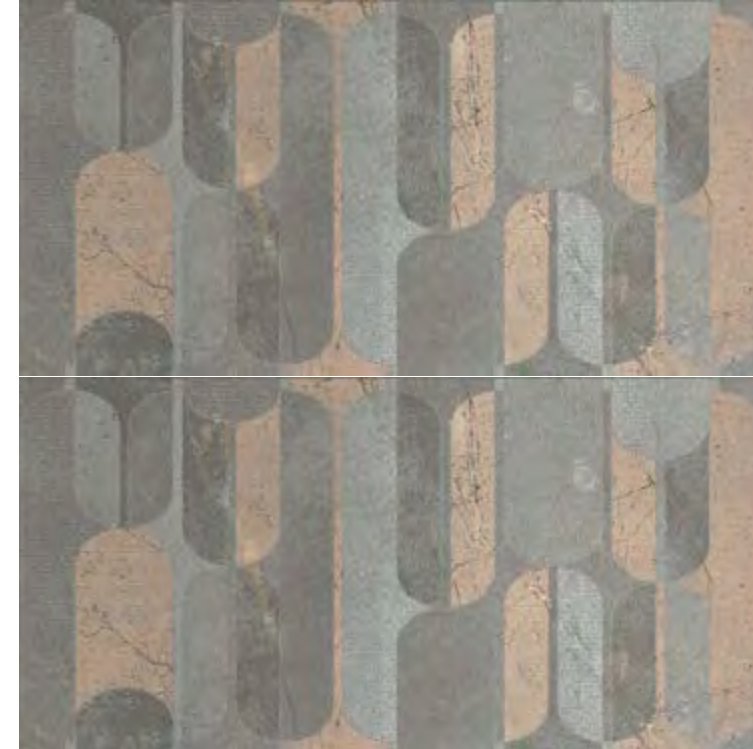

**SUPERFICIE MOLATA / BORDO RETTIFICATO**  
FASCIA ZENITH 60x120 - 24"x47" | 9 | 133503 | 401



**SUPERFICIE MOLATA / BORDO RETTIFICATO**  
COMPOSIZIONE ARCANIE 120x120 - 47"x47" (2 PCS) | 9 | 133504 | 489

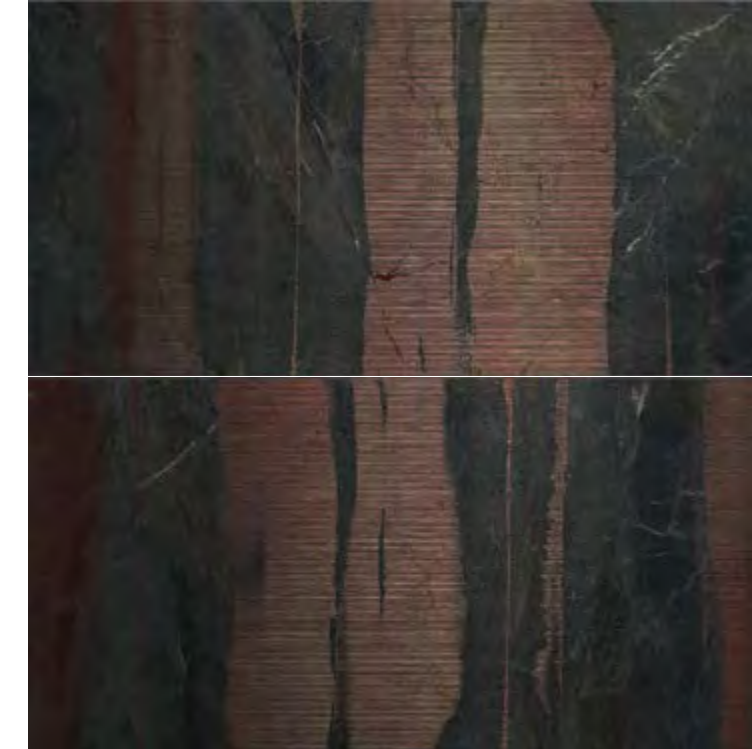

**SUPERFICIE MOLATA / BORDO RETTIFICATO**  
FASCIA OBSIDIAN 60x120 - 24"x47" | 9 | 133502 | 401

## Index

- The Company
- Technology
- Sizes
- Thicknesses
- Surfaces
- Porcelain stoneware
- Ecologycare
- Certifications
- Quality and Safety
- Ceramic of Italy
- Fincibec Group
- Campus
- Engineering
- Pools & Wellness
- Facades
- Raised Flooring
- Technical Specifications

### ➤ Contents by collection

- |                |                 |
|----------------|-----------------|
| Archè          | Geobrick        |
| Ashley         | Graphis         |
| <b>Azimuth</b> | On Stage        |
| Blade          | Pietra Castello |
| Charisma       | Pietre Naturali |
| Dicta          | Tradition       |
| Dolomite       | Transalp        |
| Esprit         | Woodtime        |
| Evolution      | Yukon           |
| Gamut          | Major           |

### ➤ Contents by effect

- WOOD - Legno
- MARBLE - Marmo
- STONE - Pietra
- CONCRETE - Cemento

### ➤ Color Index

Color Index Major 20mm

# Azimuth

Fine porcelain stoneware - Gres fine porcellanato  
Grès cérame fin - Feinsteinzeug - Gres fine porcelánico

stone effect - effetto pietra - effet pierre - Steineffekt - efecto piedra

Mosaics - Mosaici - Mosaïques - Mosaik - Mosaicos

SUPERFICIE NATURALE		A+B	
MOSAICO 4,7x4,7 - 1,8"x1,8" SU RETE 30x30 - 12"x12"			
GRAVITY	9	133509	253
TIME	9	133506	253
ALPHA	9	133505	253
MERIDIAN	9	133507	253
VECTOR	9	133508	253

Special pieces - Pezzi speciali - Pièces spéciales - Formstücke - Piezas especiales

*BATTISCOPA 7,1x120 - 3"x47"	BATTISCOPA 5,4x60 - 2,1"x24"	GRADONE COSTA RETTA 120x33 - 47"x13"	GRADONE ANGOLARE COSTA RETTA DX/SX 120x33 - 47"x13"
NATURALE RETT. ● 19	NATURALE RETT. ● 10	NATURALE RETT. ● 333	NATURALE RETT. ● 345
MOLATA RETT. ● 22	MOLATA RETT. ● 12	MOLATA RETT. ● 337	LAPPATA RETT. ● 349

\*Minimum order 210 pieces / Ordine minimo 210 pz / Commande minimum 210 pièces / Mindestbestellmenge 210 Stück / Pedido mínimo 210 piezas

Packaging - Imballi - Emballages - Verpackung - Embalajes

FLOOR TILES / PAVIMENTI / PAVIMENTS / GRUNDFLIESEN / AZULEJOS									
	sizes formati formats Formate formatos	120x278 47"x109,5"	120x120 47"x47"	60x120 24"x47"	60x60 24"x24"	30x120 12"x47"	120x120 47"x47" composizione	60x120 24"x47" fascia	30x30 4,7x4,7 12"x12" 1,8"x1,8" mosaico
	pc.	CASSA 20	2	2	3	3	1	2	11
	m <sup>2</sup>	66,7	2,88	1,44	1,08	1,08	1,44	1,44	1,0
	kg	1250	58	31	22,5	23	30,50	30,50	20,3
	colli	CAVALLA 36	20	35	40	36			36
	m <sup>2</sup>	120,2	57,6	50,4	43,2	38,88			36
	kg	2230	1160	1085	900	828			730,8

SPECIAL PIECES / PEZZI SPECIALI / PIÈCES SPÉCIALES / FORMSTÜCKE / PIEZAS ESPECIALES					
	sizes formati formats Formate formatos	5,4x60 2"x24" battiscopa	7,1x120 3"x47" battiscopa	33x120 13"x47" gradone costa retta	33x120 13"x47" gradone angolare costa retta
	pc.	14	6	1	1
	ml	8,4	7,2	1,2	1,2
	kg	11	9,4	11,2	11,7

Slip - Scivolosità - Glisance - Rutschwert - Adherencia

	Standard Norma Standard   Norm   Norme   Norme	Natural Surface Superficie Natural   Surface Naturelle Natur Oberflächen   Superficie Natural	Grip Surface Superficie Grip   Surface Grip Grip Oberflächen   Superficie Grip	Brushed Surface Superficie Molata   Surface Adouci Geschliffen Oberflächen   Superficie Molida
	B.C.R.A. (D.M.I. n. 236 μ>0,4)	> 0,40	> 0,40	-
	ANSI A 326.3 (DCOF WET >0,42)	> 0,42	> 0,42	-
	DIN EN 16165 Annex B	R10	R11	-
	DIN EN 16165 Annex A	A+B MOSAICO 4,7x4,7	A+B+C	-
	BS EN 16165 ANNEX C	-	≥ 36 DRY ≥ 36 WET	-
	AS 4586	-	Class P4	-



# Index

- The Company
- Technology
- Sizes
- Thicknesses
- Surfaces
- Porcelain stoneware
- Ecologycare
- Certifications
- Quality and Safety
- Ceramic of Italy
- Fincibec Group
- Campus
- Engineering
- Pools & Wellness
- Facades
- Raised Flooring
- Technical Specifications

## Contents by collection

- Archè
- Ashley
- Azimuth**
- Blade
- Charisma
- Dicta
- Dolomite
- Esprit
- Evolution
- Gamut
- Geobrick
- Graphis
- On Stage
- Pietra Castello
- Pietre Naturali
- Tradition
- Transalp
- Woodtime
- Yukon
- Major

## Contents by effect

- WOOD - Legno
- MARBLE - Marmo
- STONE - Pietra
- CONCRETE - Cemento

## Color Index

Color Index Major 20mm

# Pietra Castello

Fine porcelain stoneware - Gres fine porcellanato  
Grès cérame fin - Feinsteinzeug - Gres fine porcelánico

download  
catalogue



watch  
the video



Colours - Colori  
Couleurs - Farben - Colores

Miramare

60x120 cm  
60x60 cm  
30x60 cm  
50x50 cm  
25x50 cm  
25x25 cm

Torrechiara

Thicknesses - Spessori  
Epaisseurs - Dicken - Espesores

9 mm  
10 mm

Burgos

Fenis

Bard

**V3** Medium variation - Media variazione  
Moyenne variation  
Mittlerer Farbunterschied  
Media Variación

Sizes - Formati  
Formats - Formaten - Formatos

Surfaces - Superfici  
Surfaces - Oberflächen - Superficies

Natural - Naturale  
Naturelle - Natur - Natural

Grip

Edges - Bordi  
Bordes - Kanten - Bordes

Natural - Naturale  
Naturelle - Natur - Natural

Rectified - Rettificato  
Rectifié - Rektifiziert - Rectificado

ISO 13006 Bla - EN 14411/G  
Fully-resistant flooring  
Pavimenti a resistenza totale  
Sols à résistance totale - Absolut widerständige  
Fußböden - Pavimentos de resistencia total



**c5** Floor tiles recommended for heavy uses.  
Piastrille da pavimento consigliate per calpestio intenso.  
Carreaux de sol recommandés pour un trafic piétonnier intense.  
Bodenfliesen, empfohlen für intensive Beanspruchung.  
Baldosas de suelo recomendadas para tránsito intenso.

stone effect - effetto pietra - effet pierre - Steineffekt - efecto piedra

## Index

The Company  
Technology  
Sizes  
Thicknesses  
Surfaces  
Porcelain stoneware  
Ecologycare  
Certifications  
Quality and Safety  
Ceramic of Italy  
Fincibec Group  
Campus  
Engineering  
Pools & Wellness  
Facades  
Raised Flooring  
Technical Specifications

### > Contents by collection

Archè	Geobrick
Ashley	Graphis
Azimuth	On Stage
Blade	<b>Pietra Castello</b>
Charisma	Pietre Naturali
Dicta	Tradition
Dolomite	Transalp
Esprit	Woodtime
Evolution	Yukon
Gamut	Major

### > Contents by effect

WOOD - Legno  
MARBLE - Marmo  
STONE - Pietra  
CONCRETE - Cemento

### > Color Index

Color Index Major 20mm

# Pietra Castello

Fine porcelain stoneware - Gres fine porcellanato  
Grès cérame fin - Feinsteinzeug - Gres fine porcelánico

stone effect - effetto pietra - effet pierre - Steineffekt - efecto piedra

## Miramare



SUPERFICIE NATURALE / BORDO RETTIFICATO		R9	
60x120 - 24"x47"	9	124818	93
60x60 - 24"x24"	9	124823	69
30x60 - 12"x24"	9	124826	63

SUPERFICIE GRIP / BORDO NATURALE		A+B+C R11	
50x50 - 20"x20"	10	124786	63
25x50 - 10"x20"	10	124778	63
25x25 - 10"x10"	10	124830	63

## Torrechiara



SUPERFICIE NATURALE / BORDO RETTIFICATO		R9	
60x120 - 24"x47"	9	124820	93
60x60 - 24"x24"	9	124825	69
30x60 - 12"x24"	9	124828	63

SUPERFICIE GRIP / BORDO NATURALE		A+B+C R11	
50x50 - 20"x20"	10	124787	63
25x50 - 10"x20"	10	124779	63
25x25 - 10"x10"	10	124831	63

## Burgos



SUPERFICIE GRIP / BORDO NATURALE		A+B+C R11	
50x50 - 20"x20"	10	124791	63
25x50 - 10"x20"	10	124781	63
25x25 - 10"x10"	10	124833	63

## Fenis

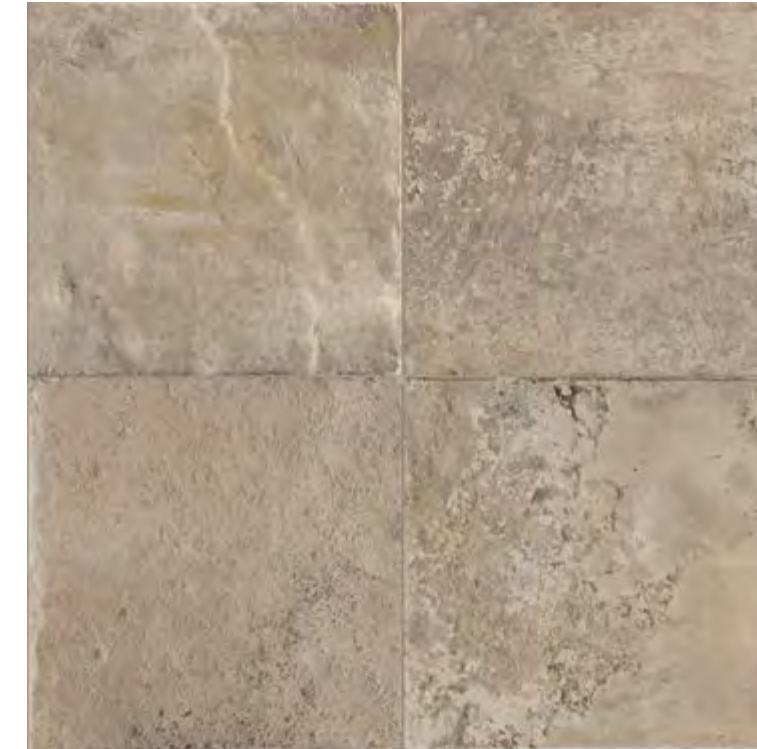

SUPERFICIE GRIP / BORDO NATURALE		A+B+C R11	
50x50 - 20"x20"	10	124789	63
25x50 - 10"x20"	10	124780	63
25x25 - 10"x10"	10	124832	63

# Index

- The Company
- Technology
- Sizes
- Thicknesses
- Surfaces
- Porcelain stoneware
- Ecologycare
- Certifications
- Quality and Safety
- Ceramic of Italy
- Fincibec Group
- Campus
- Engineering
- Pools & Wellness
- Facades
- Raised Flooring
- Technical Specifications

## > Contents by collection

- |           |                        |
|-----------|------------------------|
| Archè     | Geobrick               |
| Ashley    | Graphis                |
| Azimuth   | On Stage               |
| Blade     | <b>Pietra Castello</b> |
| Charisma  | Pietre Naturali        |
| Dicta     | Tradition              |
| Dolomite  | Transalp               |
| Esprit    | Woodtime               |
| Evolution | Yukon                  |
| Gamut     | Major                  |

## > Contents by effect

- WOOD - Legno
- MARBLE - Marmo
- STONE - Pietra
- CONCRETE - Cemento

## > Color Index

Color Index Major 20mm

# Pietra Castello

Fine porcelain stoneware - Gres fine porcellanato  
Grès cérame fin - Feinsteinzeug - Gres fine porcelánico

## Bard



SUPERFICIE NATURALE / BORDO RETTIFICATO		R9	
60x120 - 24"x47"	9	124819	93
60x60 - 24"x24"	9	124824	69
30x60 - 12"x24"	9	124827	63

## Decors - Decori - Eléments décoratifs - Dekore - Decoraciones



SUPERFICIE NATURALE / BORDO RETTIFICATO			
* ESTENSE 60x120 - 24"x47"	9	124835	143



SUPERFICIE NATURALE / BORDO RETTIFICATO			
* RIVOLI 30x120 - 12"x47"	9	124834	143

\*Decors version with multiple subjects, packaged randomly  
(Matchable with all colours)

Versione decoro con più soggetti, confezionati random  
(Abbinabili a tutti i colori)

Version décoration avec plusieurs motifs, emballés de manière  
aléatoire (pouvant être assortis à toutes les couleurs)

Dekorierter Ausführung mit mehreren Darstellungen, zufällige  
Zusammenstellung (kann mit allen Farben kombiniert werden)

Versión decoración con varios temas, empaquetados de modo  
aleatorio (se puede combinar con todos los colores)

stone effect - effetto pietra - effet pierre - Steineffekt - efecto piedra

## Mosaics - Mosaici - Mosaïques - Mosaik - Mosaicos

SUPERFICIE NATURALE		A+B		SUPERFICIE NATURALE			
MOSAICO 4,7x4,7 - 1,8"x1,8" SU RETE 30x30 - 12"x12"				MOSAICO 10x3 - 4"x1" SU RETE 30x30 - 12"x12"			
MIRAMARE	9	125182	253	MIRAMARE	9	125439	329
TORRECHIARA	9	125184	253	TORRECHIARA	9	125440	329
BARD	9	125183	253	BARD	9	125438	329

## Special pieces - Pezzi speciali - Pièces spéciales - Formstücke - Piezas especiales

BATTISCOPA 5,4x60 - 2,1"x24"	10	BATTISCOPA 8x50 - 3"x20"	8
NATURALE RETT.		GRIP	
GRADINO 30x60 - 12"x24"	55	ELEMENTO ELLE MONOLITICO 15x30x4 - 6"x12" x1,5"	22
NATURALE RETT.		GRIP	
GRADONE COSTA RETTA 120x33 - 47"x13"	333	GRADONE ANGOLARE COSTA RETTA DX/SX 120x33 - 47"x13"	345
NATURALE RETT.		NATURALE RETT.	

Minimum order 5 pieces /  
Ordine minimo 5 pz /  
Commande minimum 5 pièces /  
Mindestbestellmenge 5 Stück /  
Pedido mínimo 5 piezas

## Packaging - Imballi - Emballages - Verpackung - Embalajes

FLOOR TILES / PAVIMENTI / PAVIMENTS / GRUNDFLIESEN / AZULEJOS										
	sizes formati formats Formate formatos	60x120 24"x47"	30x120 12"x47"	60x60 24"x24"	30x60 12"x24"	50x50 20"x20"	25x50 10"x20"	25x25 10"x10"	30x30 4,7x4,7 12"x12" 1,8"x1,8" mosaico	30x30 10x3 12"x12" 4"x1" mosaico
boxes colli boîtes Kartons cajas	pc.	2	3	3	6	4	9	17	11 fogli	5
	m <sup>2</sup>	1,44	1,08	1,08	1,08	1	1,125	1,06	1	0,45
	kg	31,00	23,00	22,50	22,4	21,5	22,7	22,8	20,30	9
pallets pallet palette Paletts paletas	colli	35	36	40	48	36	54	57	-	-
	m <sup>2</sup>	50,4	38,88	43,2	51,84	36	60,75	60,59	-	-
	kg	1085	828	900	1075,2	774	1230	1299	-	-

SPECIAL PIECES / PEZZI SPECIALI / PIÈCES SPÉCIALES / FORMSTÜCKE / PIEZAS ESPECIALES							
	sizes formati formats Formate formatos	5,4x60 2,1"x24" battiscopa	8x50 3"x20" battiscopa	15x30x4 6"x12" x1,5" elemento elle monolitico	30x60 12"x24" gradino	33x120 13"x47" gradone costa retta	33x120 13"x47" gradone angolare costa retta
boxes colli boîtes Kartons cajas	pc.	14	20	6	1	1	1
	ml	8,4	10	1,8	0,6	1,2	1,2
	kg	11,0	22,5	8,1	3,5	11,2	11,7

## Slip - Scivolosità - Glissance - Rutschwert - Adherencia

	Standard Norma Standard   Norm   Norme   Norme	Natural Surface Superficie Natural   Surface Naturelle Natur Oberflächen   Superficie Natural	Grip Surface Superficie Grip   Surface Grip Grip Oberflächen   Superficie Grip
	B.C.R.A. (D.M.I. n. 236 μ>0,4)	> 0,40	> 0,40
	ANSI A 326.3 (DCOF WET >0,42)	> 0,42	> 0,42
	DIN EN 16165 ANNEX B	R9	R11
	DIN EN 16165 ANNEX A	A+B MOSAICO 4,7x4,7	A+B+C
	BS EN 16165 ANNEX C	-	≥ 36 Dry / ≥ 36 Wet
	AS 4586	-	Class P4

# Index

- The Company
- Technology
- Sizes
- Thicknesses
- Surfaces
- Porcelain stoneware
- Ecologycare
- Certifications
- Quality and Safety
- Ceramic of Italy
- Fincibec Group
- Campus
- Engineering
- Pools & Wellness
- Facades
- Raised Flooring
- Technical Specifications

## Contents by collection

- Archè
- Ashley
- Azimuth
- Blade
- Charisma
- Dicta
- Dolomite
- Esprit
- Evolution
- Gamut
- Geobrick
- Graphis
- On Stage
- Pietra Castello**
- Pietre Naturali
- Tradition
- Transalp
- Woodtime
- Yukon
- Major

## Contents by effect

- WOOD - Legno
- MARBLE - Marmo
- STONE - Pietra
- CONCRETE - Cemento

## Color Index

Color Index Major 20mm

# Charisma

Fine porcelain stoneware - Gres fine porcellanato  
Grès cérame fin - Feinsteinzeug - Gres fine porcelánico

download  
catalogue



Colours - Colori  
Couleurs - Farben - Colores

Dakota

Luxor

Trend

Imperial

Sizes - Formati  
Formats - Formaten - Formatos

120x278 cm  
(\*120x260 cm)  
120x120 cm  
60x120 cm  
80x80 cm  
60x60 cm  
30x60 cm

Thicknesses - Spessori  
Epaisseurs - Dicken - Espesores

7 mm  
9 mm

Surfaces - Superfici  
Surfaces - Oberflächen - Superficies

Natural - Naturale  
Naturelle - Natur - Natural

Lapped - Lappata  
Rodée - Geläpft - Bruñida

Grip

Edges - Bordi  
Bordes - Kanten - Bordes

Rectified - Rettificato  
Rectifié - Rektifiziert - Rectificado

ISO 13006 Bla - EN 14411/G  
Fully-resistant flooring  
Pavimenti a resistenza totale  
Sols à résistance totale - Absolut widerständige  
Fußböden - Pavimentos de resistencia total



**c4** Floor tiles recommended for medium traffic areas.  
Piastrelle da pavimento consigliate per calpestio medio.  
Carreaux de sol recommandés pour un trafic piétonnier moyen.  
Bodenfliesen, empfohlen für mittlere Beanspruchung.  
Baldosas de suelo recomendadas para el tránsito medio.

**c5** Floor tiles recommended for heavy uses.  
Piastrelle da pavimento consigliate per calpestio intenso.  
Carreaux de sol recommandés pour un trafic piétonnier intense.  
Bodenfliesen, empfohlen für intensive Beanspruchung.  
Baldosas de suelo recomendadas para tránsito intenso.

\* cm 120x260  
after after out of stock  
fino ad esaurimento scorte  
jusqu'à épuisement des stocks  
hasta agotar el stock  
solange der Vorrat reicht

**v2** Light variation - Lieve variazione  
Variation légère  
Gerinde Farbunterschied  
Variación escasa

stone effect - effetto pietra - effet pierre - Steineffekt - efecto piedra

## Index

The Company  
Technology  
Sizes  
Thicknesses  
Surfaces  
Porcelain stoneware  
Ecologycare  
Certifications  
Quality and Safety  
Ceramic of Italy  
Fincibec Group  
Campus  
Engineering  
Pools & Wellness  
Facades  
Raised Flooring  
Technical Specifications

### Contents by collection

Archè	Geobrick
Ashley	Graphis
Azimuth	On Stage
Blade	Pietra Castello
<b>Charisma</b>	Pietre Naturali
Dicta	Tradition
Dolomite	Transalp
Esprit	Woodtime
Evolution	Yukon
Gamut	Major

### Contents by effect

WOOD - Legno  
MARBLE - Marmo  
STONE - Pietra  
CONCRETE - Cemento

### Color Index

Color Index Major 20mm



## Trend

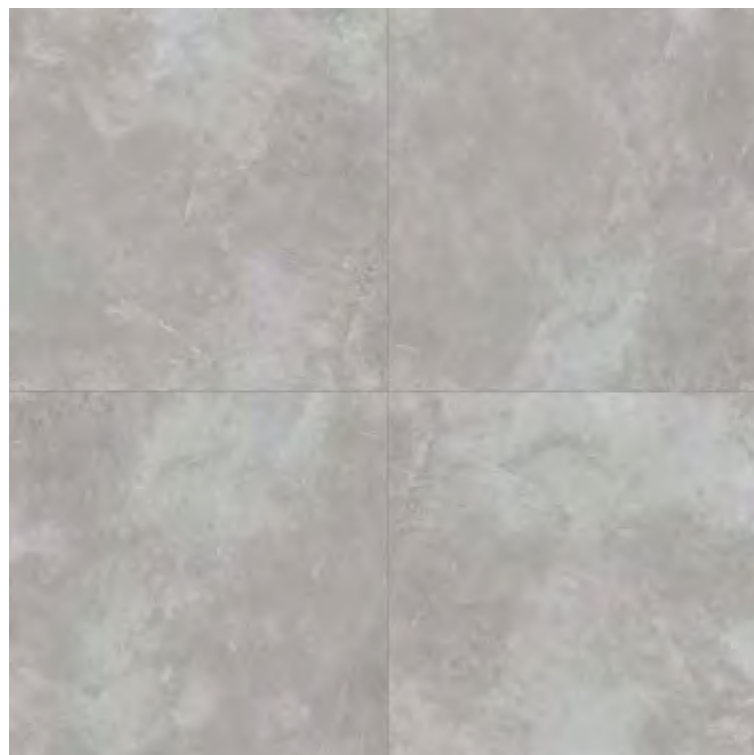

### SUPERFICIE NATURALE / BORDO RETTIFICATO **R9**

▲ 120x120 - 47"x47"	9	107694	127
60x120 - 24"x47"	9	107717	93
80x80 - 31,5"x31,5"	9	107727	93
60x60 - 24"x24"	9	107738	69
30x60 - 12"x24"	9	107748	63

### SUPERFICIE LAPPATA / BORDO RETTIFICATO

▲ 120x120 - 47"x47"	9	107698	163
60x120 - 24"x47"	9	107722	109
80x80 - 31,5"x31,5"	9	107733	109
60x60 - 24"x24"	9	107743	83

### SUPERFICIE GRIP / BORDO RETTIFICATO **A+B+C R11**

60x120 - 24"x47"	9	112853	93
------------------	---	--------	----

\* cm 120x260  
after after out of stock  
fino ad esaurimento scorte  
jusqu'à épuisement des stocks  
hasta agotar el stock  
solange der Vorrat reicht

▲ cm 120x278/120x260 pallet surcharge 140 € - stand containing 295 €  
cm 120x278/120x260 addebito cassa 140 € - cavalla 295 €  
cm 120x278/120x260 surtaxe caisse 140 € - chevalet 295 €  
cm 120x278/120x260 Aufpreis Kiste 140 € - Ständer 295 €  
cm 120x278/120x260 recargo caja 140 € - soporte 295 €

▲ cm 120x120 split pallet surcharge 40 € each - lightened stand containing 95 €  
cm 120x120 addebito frazione di paletta 40 € - cavalla alleggerita 95 €  
cm 120x120 surtaxe contremarque 40 € - chevalet allégé 95 €  
cm 120x120 Aufpreis Teilpalette 40 € - leichter Ständer 95 €  
cm 120x120 recargo fracción de paleta 40 € - soporte ligero 95 €

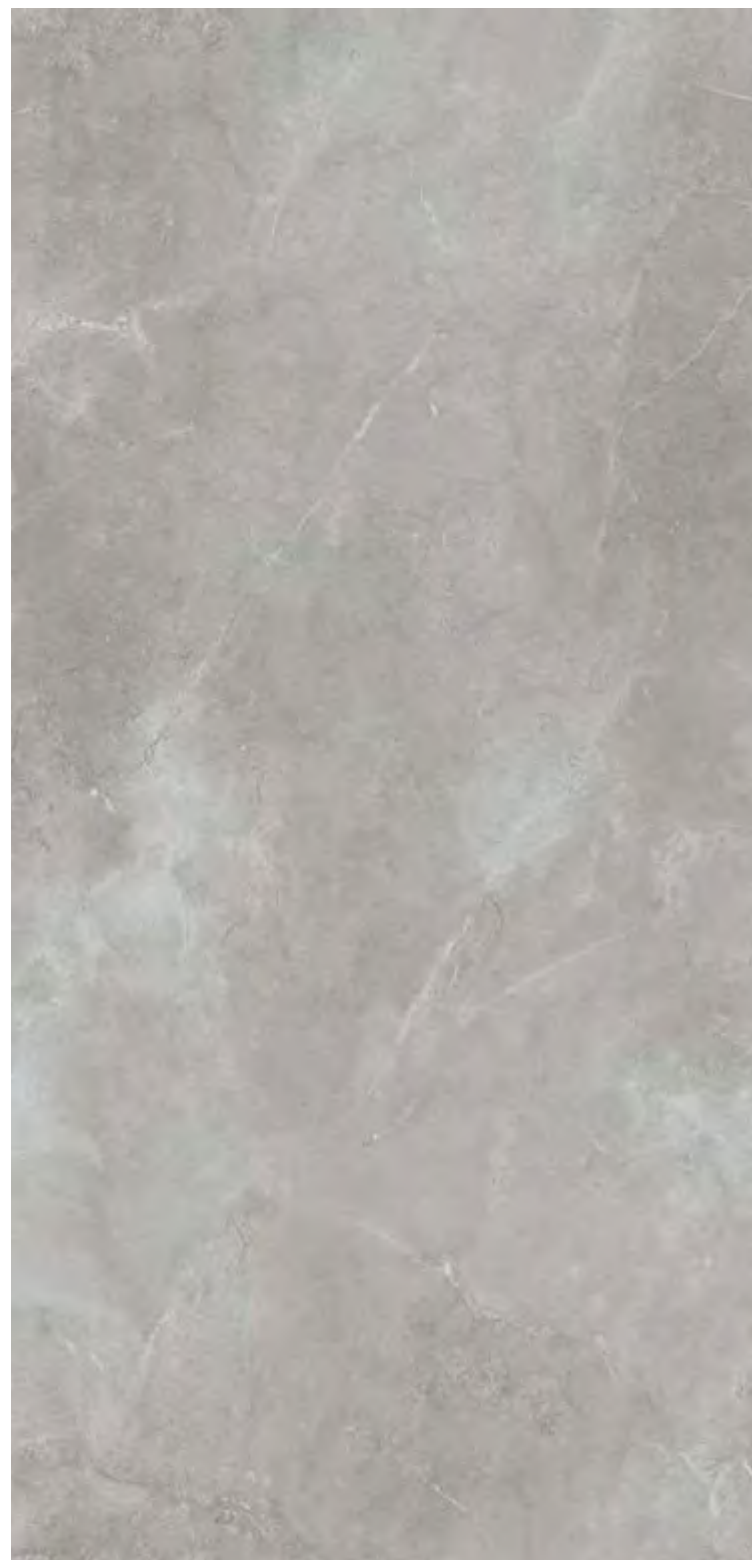

### SUPERFICIE LAPPATA / BORDO RETTIFICATO

*▲ 120x260 - 47"x102"	7	107705	213
▲ 120x278 - 47"x109"	7	137878	213

## Imperial

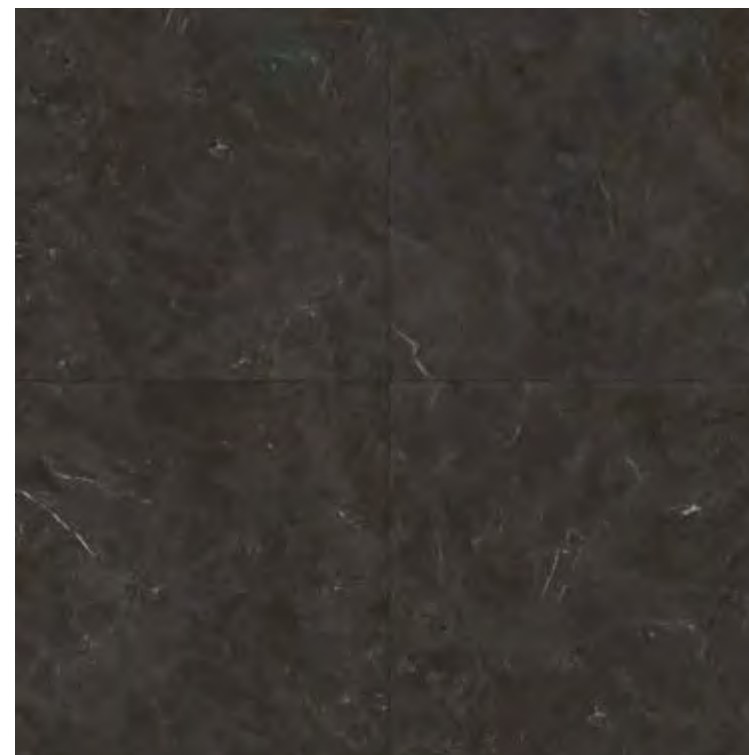

### SUPERFICIE NATURALE / BORDO RETTIFICATO **R9**

▲ 120x120 - 47"x47"	9	107693	127
60x120 - 24"x47"	9	107716	93
60x60 - 24"x24"	9	107737	69
30x60 - 12"x24"	9	107747	63

\* cm 120x260  
after after out of stock  
fino ad esaurimento scorte  
jusqu'à épuisement des stocks  
hasta agotar el stock  
solange der Vorrat reicht

▲ cm 120x278/120x260 pallet surcharge 140 € - stand containing 295 €  
cm 120x278/120x260 addebito cassa 140 € - cavalla 295 €  
cm 120x278/120x260 surtaxe caisse 140 € - chevalet 295 €  
cm 120x278/120x260 Aufpreis Kiste 140 € - Ständer 295 €  
cm 120x278/120x260 recargo caja 140 € - soporte 295 €

▲ cm 120x120 split pallet surcharge 40 € each - lightened stand containing 95 €  
cm 120x120 addebito frazione di paletta 40 € - cavalla alleggerita 95 €  
cm 120x120 surtaxe contremarque 40 € - chevalet allégé 95 €  
cm 120x120 Aufpreis Teilpalette 40 € - leichter Ständer 95 €  
cm 120x120 recargo fracción de paleta 40 € - soporte ligero 95 €



### SUPERFICIE LAPPATA / BORDO RETTIFICATO

*▲ 120x260 - 47"x102"	7	109752	213
▲ 120x278 - 47"x109"	7	138441	213

# Index

- The Company
- Technology
- Sizes
- Thicknesses
- Surfaces
- Porcelain stoneware
- Ecologycare
- Certifications
- Quality and Safety
- Ceramic of Italy
- Fincibec Group
- Campus
- Engineering
- Pools & Wellness
- Facades
- Raised Flooring
- Technical Specifications

## Contents by collection

- |                 |                 |
|-----------------|-----------------|
| Archè           | Geobrick        |
| Ashley          | Graphis         |
| Azimuth         | On Stage        |
| Blade           | Pietra Castello |
| <b>Charisma</b> | Pietre Naturali |
| Dicta           | Tradition       |
| Dolomite        | Transalp        |
| Esprit          | Woodtime        |
| Evolution       | Yukon           |
| Gamut           | Major           |

## Contents by effect

- WOOD - Legno
- MARBLE - Marmo
- STONE - Pietra
- CONCRETE - Cemento

## Color Index

Color Index Major 20mm

## Luxor



### SUPERFICIE NATURALE / BORDO RETTIFICATO **R9**

▲ 120x120 - 47"x47"	9	107695	127
60x120 - 24"x47"	9	107719	93
80x80 - 31,5"x31,5"	9	107729	93
60x60 - 24"x24"	9	107740	69
30x60 - 12"x24"	9	107750	63

### SUPERFICIE LAPPATA / BORDO RETTIFICATO

▲ 120x120 - 47"x47"	9	107699	163
60x120 - 24"x47"	9	107724	109
80x80 - 31,5"x31,5"	9	107735	109
60x60 - 24"x24"	9	107745	83

### SUPERFICIE GRIP / BORDO RETTIFICATO **A+B+C R11**

60x120 - 24"x47"	9	112852	93
------------------	---	--------	----

\* cm 120x260  
after after out of stock  
fino ad esaurimento scorte  
jusqu'à épuisement des stocks  
hasta agotar el stock  
solange der Vorrat reicht

▲ cm 120x278/120x260 pallet surcharge 140 € - stand containing 295 €  
cm 120x278/120x260 addebito cassa 140 € - cavalla 295 €  
cm 120x278/120x260 surtaxe caisse 140 € - chevalet 295 €  
cm 120x278/120x260 Aufpreis Kiste 140 € - Ständer 295 €  
cm 120x278/120x260 recargo caja 140 € - soporte 295 €

### SUPERFICIE LAPPATA / BORDO RETTIFICATO

▲ 120x260 - 47"x102"	7	107704	213
▲ 120x278 - 47"x109"	7	138442	213

## Dakota



### SUPERFICIE NATURALE / BORDO RETTIFICATO **R9**

▲ 120x120 - 47"x47"	9	107696	127
60x120 - 24"x47"	9	107720	93
80x80 - 31,5"x31,5"	9	107730	93
60x60 - 24"x24"	9	107741	69
30x60 - 12"x24"	9	107751	63

### SUPERFICIE LAPPATA / BORDO RETTIFICATO

▲ 120x120 - 47"x47"	9	107700	163
60x120 - 24"x47"	9	107725	109
80x80 - 31,5"x31,5"	9	107736	109
60x60 - 24"x24"	9	107746	83

### SUPERFICIE GRIP / BORDO RETTIFICATO **A+B+C R11**

60x120 - 24"x47"	9	112851	93
------------------	---	--------	----

▲ cm 120x120 split pallet surcharge 40 € each - lightened stand containing 95 €  
cm 120x120 addebito frazione di paletta 40 € - cavalla alleggerita 95 €  
cm 120x120 surtaxe contremarque 40 € - chevalet allégé 95 €  
cm 120x120 Aufpreis Teilpalette 40 € - leichter Ständer 95 €  
cm 120x120 recargo fracción de paleta 40 € - soporte ligero 95 €

## Decors - Decori - Eléments décoratifs - Dekore - Decoraciones



### SUPERFICIE NATURALE / BORDO RETTIFICATO

* DECORO CHARISMA MIX 60x60 - 24"x24"	9	106834	103
---------------------------------------	---	--------	-----

\*Decors version with multiple subjects, packaged randomly  
(Matchable with all colours)

Versione decoro con più soggetti, confezionati random  
(Abbinabili a tutti i colori)

Version décoration avec plusieurs motifs, emballés de manière  
aléatoire (pouvant être assortis à toutes les couleurs)

Dekorierter Ausführung mit mehreren Darstellungen, zufällige  
Zusammenstellung (kann mit allen Farben kombiniert werden)

Versión decoración con varios temas, empaquetados de modo  
aleatorio (se puede combinar con todos los colores)

# Index

- The Company
- Technology
- Sizes
- Thicknesses
- Surfaces
- Porcelain stoneware
- Ecologycare
- Certifications
- Quality and Safety
- Ceramic of Italy
- Fincibec Group
- Campus
- Engineering
- Pools & Wellness
- Facades
- Raised Flooring
- Technical Specifications

## Contents by collection

- |                 |                 |
|-----------------|-----------------|
| Archè           | Geobrick        |
| Ashley          | Graphis         |
| Azimuth         | On Stage        |
| Blade           | Pietra Castello |
| <b>Charisma</b> | Pietre Naturali |
| Dicta           | Tradition       |
| Dolomite        | Transalp        |
| Esprit          | Woodtime        |
| Evolution       | Yukon           |
| Gamut           | Major           |

## Contents by effect

- WOOD - Legno
- MARBLE - Marmo
- STONE - Pietra
- CONCRETE - Cemento

## Color Index

Color Index Major 20mm



# Charisma

Fine porcelain stoneware - Gres fine porcellanato  
Grès cérame fin - Feinsteinzeug - Gres fine porcelánico



Mosaics - Mosaici - Mosaïques - Mosaik - Mosaicos

SUPERFICIE NATURALE		A+B
MOSAICO 4,7x4,7 - 1,8"x1,8" SU RETE 30x30 - 12"x12"		
IMPERIAL	9	107752 ■ 253
TREND	9	107753 ■ 253
LUXOR	9	107755 ■ 253
DAKOTA	9	107756 ■ 253

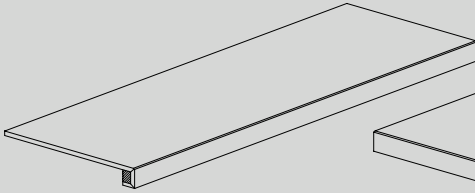
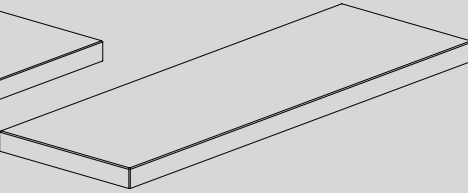
Special pieces - Pezzi speciali - Pièces spéciales - Formstücke - Piezas especiales

			
<b>BATTISCOPA 5,4x60 - 2,1"x24"</b>	<b>GRADINO 30x60 - 12"x24"</b>	<b>GRADONE COSTA RETTA 120x33 - 47"x13"</b>	<b>GRADONE ANGOLARE COSTA RETTA DX/SX 120x33 - 47"x13"</b>
NATURALE RETT. ● 10	NATURALE RETT. ● 55	NATURALE RETT. ● 333	NATURALE RETT. ● 345
LAPPATA RETT. ● 12	<b>Minimum order 5 pieces /</b> Ordine minimo 5 pz / Commande minimum 5 pièces / Mindestbestellmenge 5 Stück / Pedido mínimo 5 piezas	LAPPATA RETT. ● 337	LAPPATA RETT. ● 349

Packaging - Imballi - Emballages - Verpackung - Embalajes

FLOOR TILES / PAVIMENTI / PAVIMENTS / GRUNDFLIESEN / AZULEJOS										
	sizes formati formats Formate formatos	120x278 47"x109,5"	120x260 47"x102"	120x120 47"x47"	60x120 24"x47"	80x80 31,5"x31,5"	60x60 24"x24"	30x60 12"x24"	30x30 4,7x4,7 12"x12" 1,8"x1,8" mosaico	60x60 24"x24" decoro
 boxes colli boîtes Kartons cajas	pc.	CASSA 20	CASSA 20	2	2	2	3	6	11 fogli	3
	m <sup>2</sup>	66,7	62,4	2,88	1,44	1,28	1,08	1,08	1	1,08
	kg	1130	1060	58	31	26,20	22,50	22,4	20,30	23
 pallets pallet palette Paletts paletas	colli	CAVALLA 36	CAVALLA 36	20	35	40	40	48		
	m <sup>2</sup>	120,2	112,3	57,6	50,4	51,2	43,2	51,84		
	kg	2230	1908	1160	1085	1048	900	1075		

SPECIAL PIECES / PEZZI SPECIALI / PIÈCES SPÉCIALES / FORMSTÜCKE / PIEZAS ESPECIALES					
	sizes formati formats Formate formatos	5,4x60 2,1"x24" battiscopa	30x60 12"x24" gradino	33x120 13"x47" gradone costa retta	33x120 13"x47" gradone angolare costa retta
 boxes colli boîtes Kartons cajas	pc.	14	1	1	1
	ml	8,4	0,6	1,2	1,2
	kg	11	3,5	11,2	11,7

Slip - Scivolosità - Glisance - Rutschwert - Adherencia

	Standard Norma Standard   Norm   Norme   Norme	Natural Surface Superficie Natural   Surface Naturelle Natur Oberflächen   Superficie Natural	Grip Surface Superficie Grip   Surface Grip Grip Oberflächen   Superficie Grip	Lapped Surface Superficie Lappata   Surface Rodée Geläpft Oberflächen   Superficie Bruñida
	B.C.R.A. (D.M.I. n. 236 μ>0,4)	> 0,40	> 0,40	-
	ANSI A 326.3 (DCOF WET >0,42)	> 0,42	> 0,42	> 0,42
	DIN EN 16165 ANNEX B	R9	R11	-
	DIN EN 16165 ANNEX A	A+B MOSAICO 4,7x4,7	A+B+C	-



## Index

The Company  
Technology  
Sizes  
Thicknesses  
Surfaces  
Porcelain stoneware  
Ecologycare  
Certifications  
Quality and Safety  
Ceramic of Italy  
Fincibec Group  
Campus  
Engineering  
Pools & Wellness  
Facades  
Raised Flooring  
Technical Specifications

### Contents by collection

Archè  
Ashley  
Azimuth  
Blade  
**Charisma**  
Dicta  
Dolomite  
Esprit  
Evolution  
Gamut  
Geobrick  
Graphis  
On Stage  
Pietra Castello  
Pietre Naturali  
Tradition  
Transalp  
Woodtime  
Yukon  
Major

### Contents by effect

WOOD - Legno  
MARBLE - Marmo  
STONE - Pietra  
CONCRETE - Cemento

### Color Index

Color Index Major 20mm

# Evolution

Fine porcelain stoneware - Gres fine porcellanato  
Grès cérame fin - Feinsteinzeug - Gres fine porcelánico

download  
catalogue

watch  
the video

Colours - Colori  
Couleurs - Farben - Colores

Sizes - Formati  
Formats - Formaten - Formatos

Surfaces - Superfici  
Surfaces - Oberflächen - Superficies

Planet

Galaxy

120x120 cm

Thicknesses - Spessori  
Epaisseurs - Dicken - Espesores

9 mm

Natural - Naturale  
Naturelle - Natur - Natural

Lapped - Lappata  
Rodée - Geläpft - Bruñida

Edges - Bordi  
Bordes - Kanten - Bordes

Natural - Naturale  
Naturel - Natur - Natural

Rectified - Rettificato  
Rectifié - Rektifiziert - Rectificado

**V2** Light variation - Lieve variazione  
Variation légère  
Gerinde Farbunterschied  
Variación escasa

ISO 13006 Bla - EN 14411/G  
Fully-resistant flooring  
Pavimenti a resistenza totale  
Sols à résistance totale - Absolut widerständige  
Fußböden - Pavimentos de resistencia total



**c4** Floor tiles recommended for medium traffic areas.  
Piastrelle da pavimento consigliate per calpestio medio.  
Carreaux de sol recommandés pour un trafic piétonnier moyen.  
Bodenfliesen, empfohlen für mittlere Beanspruchung.  
Baldosas de suelo recomendadas para el tránsito medio.

**c5** Floor tiles recommended for heavy uses.  
Piastrelle da pavimento consigliate per calpestio intenso.  
Carreaux de sol recommandés pour un trafic piétonnier intense.  
Bodenfliesen, empfohlen für intensive Beanspruchung.  
Baldosas de suelo recomendadas para tránsito intenso.

stone effect - effetto pietra - effet pierre - Steineffekt - efecto piedra

## Index

The Company  
Technology  
Sizes  
Thicknesses  
Surfaces  
Porcelain stoneware  
Ecologycare  
Certifications  
Quality and Safety  
Ceramic of Italy  
Fincibec Group  
Campus  
Engineering  
Pools & Wellness  
Facades  
Raised Flooring  
Technical Specifications

### Contents by collection

Archè	Geobrick
Ashley	Graphis
Azimuth	On Stage
Blade	Pietra Castello
Charisma	Pietre Naturali
Dicta	Tradition
Dolomite	Transalp
Esprit	Woodtime
<b>Evolution</b>	Yukon
Gamut	Major

### Contents by effect

WOOD - Legno  
MARBLE - Marmo  
STONE - Pietra  
CONCRETE - Cemento

### Color Index

Color Index Major 20mm

# Evolution

Fine porcelain stoneware - Gres fine porcellanato  
Grès cérame fin - Feinsteinzeug - Gres fine porcelánico

## Planet

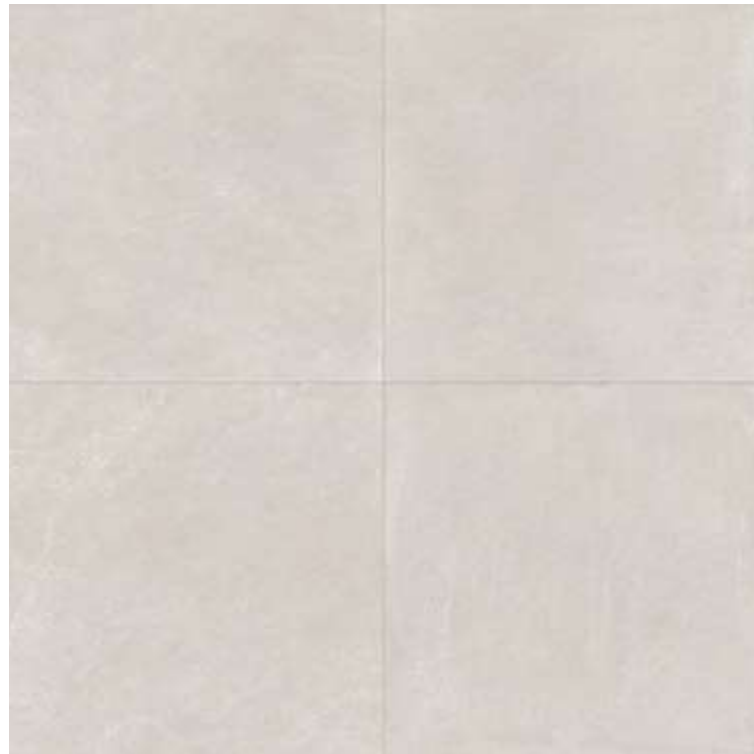

### SUPERFICIE NATURALE / BORDO RETTIFICATO **R10**

▲ 120x120 - 47"x47" 

9	113546	127
---	--------	-----

### SUPERFICIE LAPPATA / BORDO RETTIFICATO

▲ 120x120 - 47"x47" 

9	113551	163
---	--------	-----

## Galaxy



### SUPERFICIE NATURALE / BORDO RETTIFICATO **R10**

▲ 120x120 - 47"x47" 

9	113545	127
---	--------	-----

### SUPERFICIE LAPPATA / BORDO RETTIFICATO

▲ 120x120 - 47"x47" 

9	113550	163
---	--------	-----

▲ cm 120x120 split pallet surcharge 40 € each - lightened stand containing 95 €  
cm 120x120 addebito frazione di paletta 40 € - cavalla alleggerita 95 €  
cm 120x120 surtaxe contremarque 40 € - chevalet allégé 95 €  
cm 120x120 Aufpreis Teilpalette 40 € - leichter Ständer 95 €  
cm 120x120 recargo fracción de paleta 40 € - soporte ligero 95 €

# Evolution

Fine porcelain stoneware - Gres fine porcellanato  
Grès cérame fin - Feinsteinzeug - Gres fine porcelánico

## Special pieces - Pezzi speciali - Pièces spéciales - Formstücke - Piezas especiales

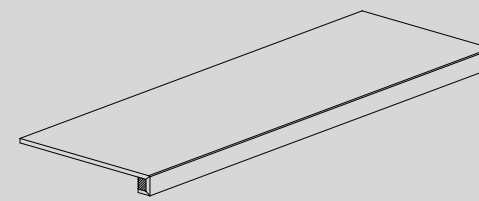

### GRADONE COSTA RETTA 120x33 - 47"x13"

NATURALE RETT. ● 333  
LAPPATA RETT. ● 337

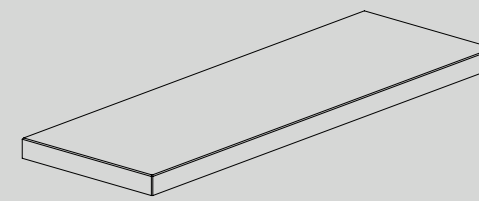

### GRADONE ANGOLARE COSTA RETTA DX/SX 120x33 - 47"x13"

NATURALE RETT. ● 345  
LAPPATA RETT. ● 349

## Packaging - Imballi - Emballages - Verpackung - Embalajes

### FLOOR TILES / PAVIMENTI / PAVIMENTS / GRUNDFLIESEN / AZULEJOS

	sizes formati formats Formate formatos	120x120 47"x47"
boxes colli boîtes Kartons cajas	pc.	2
	m <sup>2</sup>	2,88
	kg	58
pallets palet palette Paletts paletas	colli	20
	m <sup>2</sup>	57,6
	kg	1160

### SPECIAL PIECES / PEZZI SPECIALI / PIÈCES SPÉCIALES / FORMSTÜCKE / PIEZAS ESPECIALES

	sizes formati formats Formate formatos	33x120 13"x47" gradone costa retta	33x120 13"x47" gradone angolare costa retta
boxes colli boîtes Kartons cajas	pc.	1	1
	ml	1,2	1,2
	kg	11,2	11,7

## Slip - Scivolosità - Glisance - Rutschwert - Adherencia

	Standard Norma Standard   Norm   Norme   Norme	Natural Surface Superficie Natural   Surface Naturelle Natur Oberflächen   Superficie Natural	Lapped Surface Superficie Lappata   Surface Rodée Geläpft Oberflächen   Superficie Bruñida
	B.C.R.A. (D.M.I. n. 236 μ>0,4)	> 0,40	-
	ANSI A 326.3 (DCOF WET >0,42)	> 0,42	> 0,42
	DIN EN 16165 ANNEX B	R10	-

# Index

The Company  
Technology  
Sizes  
Thicknesses  
Surfaces  
Porcelain stoneware  
Ecologycare  
Certifications  
Quality and Safety  
Ceramic of Italy  
Fincibec Group  
Campus  
Engineering  
Pools & Wellness  
Facades  
Raised Flooring  
Technical Specifications

## Contents by collection

Archè  
Ashley  
Azimuth  
Blade  
Charisma  
Dicta  
Dolomite  
Esprit  
Evolution  
Gamut  
Geobrick  
Graphis  
On Stage  
Pietra Castello  
Pietre Naturali  
Tradition  
Transalp  
Woodtime  
Yukon  
Major

## Contents by effect

WOOD - Legno  
MARBLE - Marmo  
STONE - Pietra  
CONCRETE - Cemento

## Color Index

Color Index Major 20mm

# Dolomite

Fine porcelain stoneware - Gres fine porcellanato  
Gres cérame fin - Feinsteinzeug - Gres fine porcelánico

download  
catalogue



Colours - Colori  
Couleurs - Farben - Colores

White

Dust

Moon

Taupe

Grey

Dark

**V2** Light variation - Lieve variazione  
Variation légère  
Gerinde Farbunterschied  
Variación escasa

Sizes - Formati  
Formats - Formaten - Formatos

60x120 cm  
60x60 cm  
30x60 cm  
30x30 cm  
15x15 cm

Thicknesses - Spessori  
Epaisseurs - Dicken - Espesores

9 mm

Surfaces - Superfici  
Surfaces - Oberflächen - Superficies

Natural - Naturale  
Naturelle - Natur - Natural

Edges - Bordi  
Bordes - Kanten - Bordes

Rectified - Rettificato  
Rectifié - Rektifiziert - Rectificado

**F**  
20mm **MAJOR**  
50x100 cm  
PAG. 184

ISO 13006 Bla - EN 14411/G  
Fully-resistant flooring  
Pavimenti a resistenza totale  
Sols à résistance totale - Absolut widerständige  
Fußböden - Pavimentos de resistencia total



**c5** Floor tiles recommended for heavy uses.  
Piastrelle da pavimento consigliate per calpestio intenso.  
Carreaux de sol recommandés pour un trafic piétonnier intense.  
Bodenfliesen, empfohlen für intensive Beanspruchung.  
Baldosas de suelo recomendadas para tránsito intenso.

stone effect - effetto pietra - effet pierre - Steineffekt - efecto piedra

## Index

The Company  
Technology  
Sizes  
Thicknesses  
Surfaces  
Porcelain stoneware  
Ecologycare  
Certifications  
Quality and Safety  
Ceramic of Italy  
Fincibec Group  
Campus  
Engineering  
Pools & Wellness  
Facades  
Raised Flooring  
Technical Specifications

### Contents by collection

Archè	Geobrick
Ashley	Graphis
Azimuth	On Stage
Blade	Pietra Castello
Charisma	Pietre Naturali
Dicta	Tradition
<b>Dolomite</b>	Transalp
Esprit	Woodtime
Evolution	Yukon
Gamut	Major

### Contents by effect

WOOD - Legno  
MARBLE - Marmo  
STONE - Pietra  
CONCRETE - Cemento

### Color Index

Color Index Major 20mm

# Dolomite

Fine porcelain stoneware - Gres fine porcellanato  
Grès cérame fin - Feinsteinzeug - Gres fine porcelánico

stone effect - effetto pietra - effet pierre - Steineffekt - efecto piedra

## White

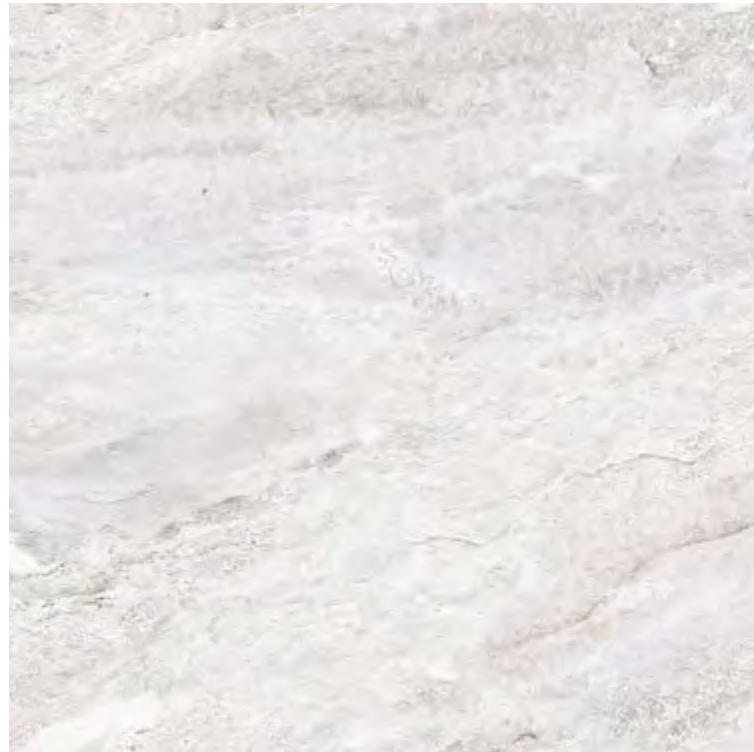

SUPERFICIE NATURALE / BORDO RETTIFICATO	A+B R10	
60x120 - 24"x47"	I 9	92909 ■ 93
60x60 - 24"x24"	I 9	92897 ■ 69
30x60 - 12"x24"	I 9	92891 ■ 63
30x30 - 12"x12" on demand ≥ 1 pl	I 9	94636 ■ 73
15x15 - 6"x6" on demand ≥ 1 pl	I 9	94642 ■ 163

## Dust

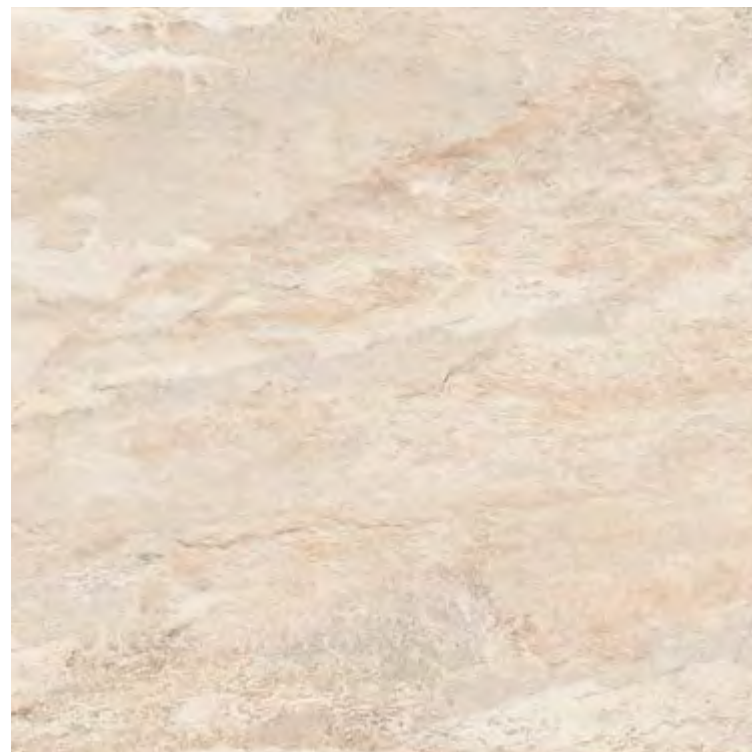

SUPERFICIE NATURALE / BORDO RETTIFICATO	A+B R10	
60x120 - 24"x47"	I 9	92906 ■ 93
60x60 - 24"x24"	I 9	92894 ■ 69
30x60 - 12"x24"	I 9	92888 ■ 63
30x30 - 12"x12" on demand ≥ 1 pl	I 9	94633 ■ 73
15x15 - 6"x6" on demand ≥ 1 pl	I 9	94639 ■ 163

## Moon

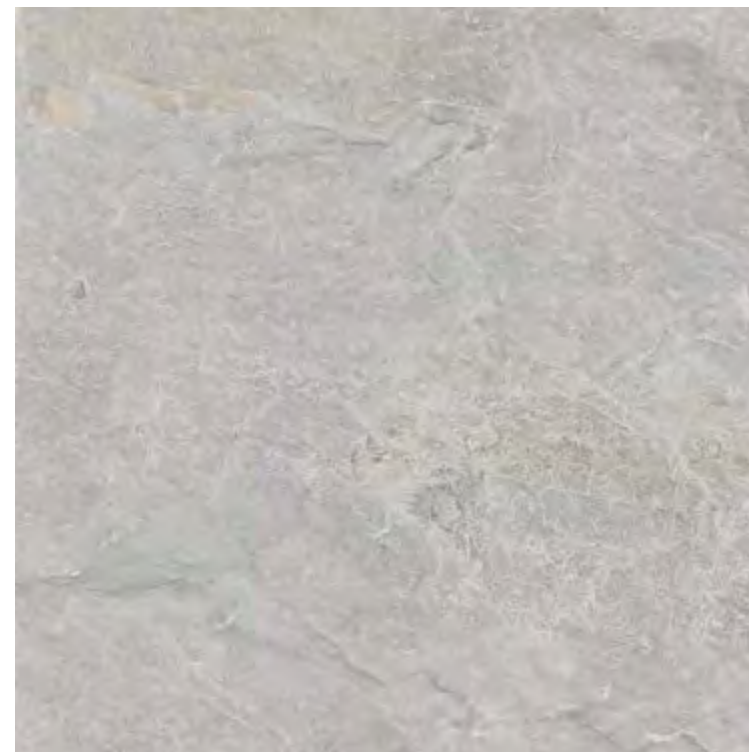

SUPERFICIE NATURALE / BORDO RETTIFICATO	A+B R10	
60x120 - 24"x47"	I 9	92905 ■ 93
60x60 - 24"x24"	I 9	92893 ■ 69
30x60 - 12"x24"	I 9	92887 ■ 63
30x30 - 12"x12" on demand ≥ 1 pl	I 9	94632 ■ 73
15x15 - 6"x6" on demand ≥ 1 pl	I 9	94638 ■ 163

## Taupe



SUPERFICIE NATURALE / BORDO RETTIFICATO	A+B R10	
60x120 - 24"x47"	I 9	99347 ■ 93
30x60 - 12"x24"	I 9	99349 ■ 63

# Index

- The Company
- Technology
- Sizes
- Thicknesses
- Surfaces
- Porcelain stoneware
- Ecologycare
- Certifications
- Quality and Safety
- Ceramic of Italy
- Fincibec Group
- Campus
- Engineering
- Pools & Wellness
- Facades
- Raised Flooring
- Technical Specifications

## > Contents by collection

- |                 |                 |
|-----------------|-----------------|
| Archè           | Geobrick        |
| Ashley          | Graphis         |
| Azimuth         | On Stage        |
| Blade           | Pietra Castello |
| Charisma        | Pietre Naturali |
| Dicta           | Tradition       |
| <b>Dolomite</b> | Transalp        |
| Esprit          | Woodtime        |
| Evolution       | Yukon           |
| Gamut           | Major           |

## > Contents by effect

- WOOD - Legno
- MARBLE - Marmo
- STONE - Pietra
- CONCRETE - Cemento

## > Color Index

Color Index Major 20mm

# Dolomite

Fine porcelain stoneware - Gres fine porcellanato  
Grès cérame fin - Feinsteinzeug - Gres fine porcelánico

## Grey



SUPERFICIE NATURALE / BORDO RETTIFICATO		A+B R10	
60x120 - 24"x47"	9 92904	■	93
60x60 - 24"x24"	9 92892	■	69
30x60 - 12"x24"	9 92886	■	63
30x30 - 12"x12" on demand ≥ 1 pl	9 94631	■	73
15x15 - 6"x6" on demand ≥ 1 pl	9 94637	■	163

## Dark



SUPERFICIE NATURALE / BORDO RETTIFICATO		A+B R10	
60x120 - 24"x47"	9 92908	■	93
60x60 - 24"x24"	9 92896	■	69
30x60 - 12"x24"	9 92890	■	63
30x30 - 12"x12" on demand ≥ 1 pl	9 94634	■	73
15x15 - 6"x6" on demand ≥ 1 pl	9 94640	■	163

## Mosaics - Mosaici - Mosaïques - Mosaik - Mosaicos

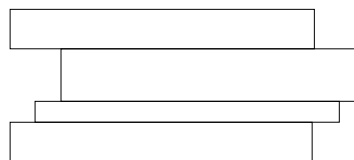

SUPERFICIE NATURALE	
Muretto 30x60 - 12"x24"	
WHITE	9 92922 ■ 233
DUST	9 92918 ■ 233
MOON	9 92917 ■ 233
TAUPE	9 102580 ■ 233
GREY	9 92916 ■ 233
DARK	9 92920 ■ 233

stone effect - effetto pietra - effet pierre - Steineffekt - efecto piedra

## Mosaics - Mosaici - Mosaïques - Mosaik - Mosaicos

SUPERFICIE NATURALE		A+B		SUPERFICIE NATURALE		A+B+C	
MOSAICO 4,7x4,7 - 1,8"x1,8" SU RETE 30x30 - 12"x12"				MOSAICO 2,5x2,5 - 1"x1" SU FOGLIO 30x30 - 12"x12"			
WHITE	9 92927	■	253	WHITE	9 95620	■	297
DUST	9 92925	■	253	DUST	9 95617	■	297
MOON	9 92924	■	253	MOON	9 95616	■	297
TAUPE	9 102582	■	253	TAUPE	9 102581	■	297
GREY	9 92923	■	253	GREY	9 95615	■	297
DARK	9 92926	■	253	DARK	9 95619	■	297

## Special pieces - Pezzi speciali - Pièces spéciales - Formstücke - Piezas especiales

<b>BATTISCOPIA 5,4x60 - 2,1"x24"</b> NATURALE RETT. ● 10	<b>GRADINO 30x60 - 12"x24"</b> NATURALE RETT. ● 55	<b>GRADONE COSTA RETTA 120x33 - 47"x13"</b> NATURALE RETT. ● 333	<b>GRADONE ANGOLARE COSTA RETTA DX/SX 120x33 - 47"x13"</b> NATURALE RETT. ● 345
<b>LISTELLO ALLUMINIO 1,5x100 - 0,6"x40"</b> 33399 ● 22	<b>Minimum order 5 pieces /</b> Ordine minimo 5 pz / Commande minimum 5 pièces / Mindestbestellmenge 5 Stück / Pedido mínimo 5 piezas		

## Packaging - Imballi - Emballages - Verpackung - Embalajes

FLOOR TILES / PAVIMENTI / PAVIMENTS / GRUNDFLIESEN / AZULEJOS									
sizes formats Formats formatos	60x120 24"x47"	60x60 24"x24"	30x60 12"x24"	30x30 12"x12"	15x15 6"x6"	30x60 12"x24" muretto	30x30 4,7x4,7 12"x12" 1,8"x1,8" mosaico	30x30 2,5x2,5 12"x12" 1"x1" mosaico	
	2	3	6	11	44	6	11 fogli	11 fogli	
<b>boxes colli boîtes Kartons cajas</b>	pc.								
	m <sup>2</sup>	1,44	1,08	1,08	1,0	0,99	1,08	1	1
	kg	31,00	22,50	22,0	23,0	17,9	23,0	18,0	18,0
	<b>pallets pallet palette Paletts paletas</b>	35	40	48	50	48			
	m <sup>2</sup>	50,4	43,2	51,8	50	47,5			
	kg	1085	900	1056	1150	860			

SPECIAL PIECES / PEZZI SPECIALI / PIÈCES SPÉCIALES / FORMSTÜCKE / PIEZAS ESPECIALES						
sizes formats Formate formatos	5,4x60 2,1"x24" battiscopa	1,5x100 0,6"x40" listello alluminio	30x60 12"x24" gradino	33x120 13"x47" gradone costa retta	33x120 13"x47" gradone angolare costa retta	
	14	6	1	1	1	
<b>boxes colli boîtes Kartons cajas</b>	pc.					
	ml	8,4	0,6	1,2	1,2	
	kg	11,0	0,6	3,5	11,2	11,7

## Slip - Scivolosità - Glissance - Rutschwert - Adherencia

	Standard Norma Standard   Norm   Norme   Norme	Natural Surface Superficie Natural   Surface Naturelle Natur Oberflächen   Superficie Natural
	B.C.R.A. (D.M.I. n. 236 μ>0,4)	> 0,40
	ANSI A 326.3 (DCOF WET >0,42)	> 0,42
	DIN EN 16165 ANNEX B	R10
	DIN EN 16165 ANNEX A	A+B MOSAICO 4,7x4,7 A+B A+B+C MOSAICO 2,5x2,5

# Index

- The Company
- Technology
- Sizes
- Thicknesses
- Surfaces
- Porcelain stoneware
- Ecologycare
- Certifications
- Quality and Safety
- Ceramic of Italy
- Fincibec Group
- Campus
- Engineering
- Pools & Wellness
- Facades
- Raised Flooring
- Technical Specifications

## Contents by collection

- Archè
- Ashley
- Azimuth
- Blade
- Charisma
- Dicta
- Dolomite**
- Esprit
- Evolution
- Gamut
- Geobrick
- Graphis
- On Stage
- Pietra Castello
- Pietre Naturali
- Tradition
- Transalp
- Woodtime
- Yukon
- Major

## Contents by effect

- WOOD - Legno
- MARBLE - Marmo
- STONE - Pietra
- CONCRETE - Cemento

## Color Index

Color Index Major 20mm



# Geobrick

Fine porcelain stoneware - Gres fine porcellanato  
Grès cérame fin - Feinsteinzeug - Gres fine porcelánico

download  
catalogue



Colours - Colori  
Couleurs - Farben - Colores

Volterra

Bruges

Siena

Canossa

**V3** Medium variation - Media variazione  
Moyenne variation  
Mittlerer Farbunterschied  
Media Variación

Sizes - Formati  
Formats - Formaten - Formatos

60x60 cm  
30x60 cm  
30x30 cm  
50x50 cm  
25x50 cm  
25x25 cm  
6,2x25 cm

Thicknesses - Spessori  
Epaisseurs - Dicken - Espesores

9 mm  
10 mm

Surfaces - Superfici  
Surfaces - Oberflächen - Superficies

Natural - Naturale  
Naturelle - Natur - Natural

Grip

Edges - Bordi  
Bordes - Kanten - Bordes

Rectified - Rettificato  
Rectifié - Rektifiziert - Rectificado

Natural - Naturale  
Naturel - Natur - Natural

**F**  
20mm  
**MAJOR**  
80x80 cm  
60x60 cm  
PAG. 187

ISO 13006 B1a - EN 14411/G  
Fully-resistant flooring  
Pavimenti a resistenza totale  
Sols à résistance totale - Absolut widerständige  
Fußböden - Pavimentos de resistencia total



**c5** Floor tiles recommended for heavy uses.  
Piastrille da pavimento consigliate per calpestio intenso.  
Carreaux de sol recommandés pour un trafic piétonnier intense.  
Bodenfliesen, empfohlen für intensive Beanspruchung.  
Baldosas de suelo recomendadas para tránsito intenso.

stone effect - effetto pietra - effet pierre - Steineffekt - efecto piedra

## Index

The Company  
Technology  
Sizes  
Thicknesses  
Surfaces  
Porcelain stoneware  
Ecologycare  
Certifications  
Quality and Safety  
Ceramic of Italy  
Fincibec Group  
Campus  
Engineering  
Pools & Wellness  
Facades  
Raised Flooring  
Technical Specifications

### Contents by collection

Archè	Geobrick
Ashley	Graphis
Azimuth	On Stage
Blade	Pietra Castello
Charisma	Pietre Naturali
Dicta	Tradition
Dolomite	Transalp
Esprit	Woodtime
Evolution	Yukon
Gamut	Major

### Contents by effect

WOOD - Legno  
MARBLE - Marmo  
STONE - Pietra  
CONCRETE - Cemento

### Color Index

Color Index Major 20mm

## Volterra



SUPERFICIE NATURALE / BORDO RETTIFICATO		R10	
60x60 - 24"x24"	9	100690	69
30x60 - 12"x24"	9	100695	63
30x30 - 12"x12"	9	100700	73

SUPERFICIE GRIP / BORDO NATURALE		A+B+C R11	
50x50 - 20"x20"	10	94845	63
25x50 - 10"x20"	10	94849	63
25x25 - 10"x10"	10	94853	63
6,5x25 - 2,4"x10"	10	96151	163

## Bruges

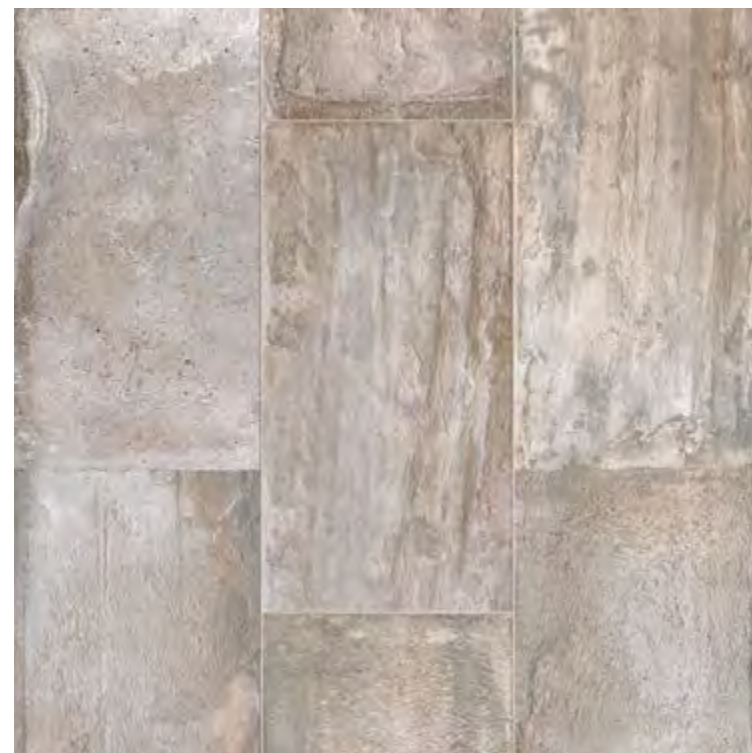

SUPERFICIE GRIP / BORDO NATURALE		A+B+C R11	
50x50 - 20"x20"	10	94846	63
25x50 - 10"x20"	10	94850	63
25x25 - 10"x10"	10	94854	63
6,5x25 - 2,4"x10"	10	96148	163

## Siena



SUPERFICIE GRIP / BORDO NATURALE		A+B+C R11	
50x50 - 20"x20"	10	94844	63
25x50 - 10"x20"	10	94848	63
25x25 - 10"x10"	10	94852	63
6,5x25 - 2,4"x10"	10	96150	163

## Canossa



SUPERFICIE GRIP / BORDO NATURALE		A+B+C R11	
50x50 - 20"x20"	10	94843	63
25x50 - 10"x20"	10	94847	63
25x25 - 10"x10"	10	94851	63
6,5x25 - 2,4"x10"	10	96149	163

# Index

- The Company
- Technology
- Sizes
- Thicknesses
- Surfaces
- Porcelain stoneware
- Ecologycare
- Certifications
- Quality and Safety
- Ceramic of Italy
- Fincibec Group
- Campus
- Engineering
- Pools & Wellness
- Facades
- Raised Flooring
- Technical Specifications

## > Contents by collection

- |           |                 |
|-----------|-----------------|
| Archè     | <b>Geobrick</b> |
| Ashley    | Graphis         |
| Azimuth   | On Stage        |
| Blade     | Pietra Castello |
| Charisma  | Pietre Naturali |
| Dicta     | Tradition       |
| Dolomite  | Transalp        |
| Esprit    | Woodtime        |
| Evolution | Yukon           |
| Gamut     | Major           |

## > Contents by effect

- WOOD - Legno
- MARBLE - Marmo
- STONE - Pietra
- CONCRETE - Cemento

## > Color Index

Color Index Major 20mm

## Special pieces - Pezzi speciali - Pièces spéciales - Formstücke - Piezas especiales



**BATTISCOPA 5,4x60** - 2,1"x24"  
NATURALE RETT. ● 10

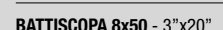

**BATTISCOPA 8x50** - 3"x20"  
GRIP ● 8



**GRADINO 30x60** - 12"x24"  
NATURALE RETT. ● 55

Minimum order 5 pieces /  
Ordine minimo 5 pz /  
Commande minimum 5 pièces /  
Mindestbestellmenge 5 Stück /  
Pedido mínimo 5 piezas

**GRADINO 25x50** - 10"x20"

GRIP ● 28

Minimum order 5 pieces /  
Ordine minimo 5 pz /  
Commande minimum 5 pièces /  
Mindestbestellmenge 5 Stück /  
Pedido mínimo 5 piezas



**ELEMENTO ELLE MONOLITICO 15x30x4** - 6"x12" x1,5"  
GRIP ● 22

## Packaging - Imballi - Emballages - Verpackung - Embalajes

### FLOOR TILES / PAVIMENTI / PAVIMENTS / GRUNDFLIESEN / AZULEJOS

	sizes formati formats Formate formatos	60x60 24"x24"	30x60 12"x24"	50x50 20"x20"	25x50 10"x20"	30x30 12"x12"	25x25 10"x10"	6,5x25 2,4"x10"
boxes colli boîtes Kartons cajas	pc.	3	6	4	9	13	17	66
	m <sup>2</sup>	1,08	1,08	1,00	1,13	1,17	1,06	1,02
	kg	22,50	22,0	21,0	23,0	22,00	22,8	22,5
pallets pallet palette Paletts paletas	colli	40	48	39	54	48	57	36
	m <sup>2</sup>	43,2	51,8	39	60,8	56,16	60,59	36,8
	kg	900	1056	819	1242	1056	1299	810

### SPECIAL PIECES / PEZZI SPECIALI / PIÈCES SPÉCIALES / FORMSTÜCKE / PIEZAS ESPECIALES

	sizes formati formats Formate formatos	5,4x60 2,1"x24" battiscopa	8x50 3"x20" battiscopa	30x60 12"x24" gradino	25x50 10"x20" gradino	15x30x4 6"x12" x1,5" elemento elle monolitico
boxes colli boîtes Kartons cajas	pc.	14	20	1	6	6
	ml	8,4	10	0,6	3	1,8
	kg	11,0	23,0	3,5	15,6	8,1

## Slip - Scivolosità - Glisance - Rutschwert - Adherencia

	Standard Norma Standard   Norm   Norme   Norme	Natural Surface Superficie Natural   Surface Naturelle Natur Oberflächen   Superficie Natural	Grip Surface Superficie Grip   Surface Grip Grip Oberflächen   Superficie Grip
	B.C.R.A. (D.M.I. n. 236 μ>0,4)	> 0,40	> 0,40
	ANSI A 326.3 (DCOF WET >0,42)	> 0,42	> 0,42
	DIN EN 16165 ANNEX B	R10	R11
	DIN EN 16165 ANNEX A	-	A+B+C
	BS EN 16165 ANNEX C	-	≥ 36 Dry / ≥ 36 Wet
	AS 4586	-	Class P4



# Index

- The Company
- Technology
- Sizes
- Thicknesses
- Surfaces
- Porcelain stoneware
- Ecologycare
- Certifications
- Quality and Safety
- Ceramic of Italy
- Fincibec Group
- Campus
- Engineering
- Pools & Wellness
- Facades
- Raised Flooring
- Technical Specifications

## Contents by collection

- Archè
- Ashley
- Azimuth
- Blade
- Charisma
- Dicta
- Dolomite
- Esprit
- Evolution
- Gamut
- Geobrick**
- Graphis
- On Stage
- Pietra Castello
- Pietre Naturali
- Tradition
- Transalp
- Woodtime
- Yukon
- Major

## Contents by effect

- WOOD - Legno
- MARBLE - Marmo
- STONE - Pietra
- CONCRETE - Cemento

## Color Index

Color Index Major 20mm

# Pietre Naturali

Fine porcelain stoneware - Gres fine porcellanato  
Grès cérame fin - Feinsteinzeug - Gres fine porcelánico

download catalogue



Colours - Colori  
Couleurs - Farben - Colores

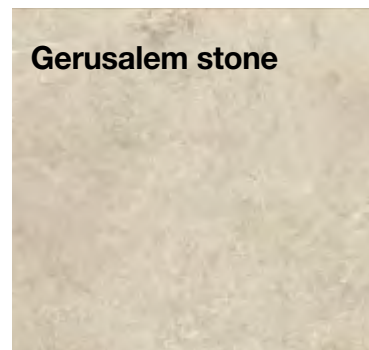

Gerusalem stone

Sizes - Formati  
Formats - Formaten - Formatos

60x120 cm  
60x60 cm  
30x60 cm  
15x60 cm

Thicknesses - Spessori  
Epaisseurs - Dicken - Espesores

9 mm

Surfaces - Superfici  
Surfaces - Oberflächen - Superficies

Natural - Naturale  
Naturelle - Natur - Natural

Grip

Edges - Bordi  
Bordes - Kanten - Bordes

Rectified - Rettificato  
Rectifié - Rektifiziert - Rectificado



**MAJOR**  
50x100 cm  
80x80 cm  
60x60 cm

PAG. 189

ISO 13006 Bla - EN 14411/G  
Fully-resistant flooring  
Pavimenti a resistenza totale  
Sols à résistance totale - Absolut widerständige  
Fußböden - Pavimentos de resistencia total



**c5** Floor tiles recommended for heavy uses.  
Piastrille da pavimento consigliate per calpestio intenso.  
Carreaux de sol recommandés pour un trafic piétonnier intense.  
Bodenfliesen, empfohlen für intensive Beanspruchung.  
Baldosas de suelo recomendadas para tránsito intenso.

**V2** Light variation - Lieve variazione  
Variation légère  
Gerinde Farbunterschied  
Variación escasa

stone effect - effetto pietra - effet pierre - Steineffekt - efecto piedra

## Index

- The Company
- Technology
- Sizes
- Thicknesses
- Surfaces
- Porcelain stoneware
- Ecologycare
- Certifications
- Quality and Safety
- Ceramic of Italy
- Fincibec Group
- Campus
- Engineering
- Pools & Wellness
- Facades
- Raised Flooring
- Technical Specifications

### Contents by collection

- |           |                        |
|-----------|------------------------|
| Archè     | Geobrick               |
| Ashley    | Graphis                |
| Azimuth   | On Stage               |
| Blade     | Pietra Castello        |
| Charisma  | <b>Pietre Naturali</b> |
| Dicta     | Tradition              |
| Dolomite  | Transalp               |
| Esprit    | Woodtime               |
| Evolution | Yukon                  |
| Gamut     | Major                  |

### Contents by effect

- WOOD - Legno
- MARBLE - Marmo
- STONE - Pietra
- CONCRETE - Cemento

### Color Index

Color Index Major 20mm

# Pietre Naturali

Fine porcelain stoneware - Gres fine porcellanato  
Grès cérame fin - Feinsteinzeug - Gres fine porcelánico

## Gerusalem Stone

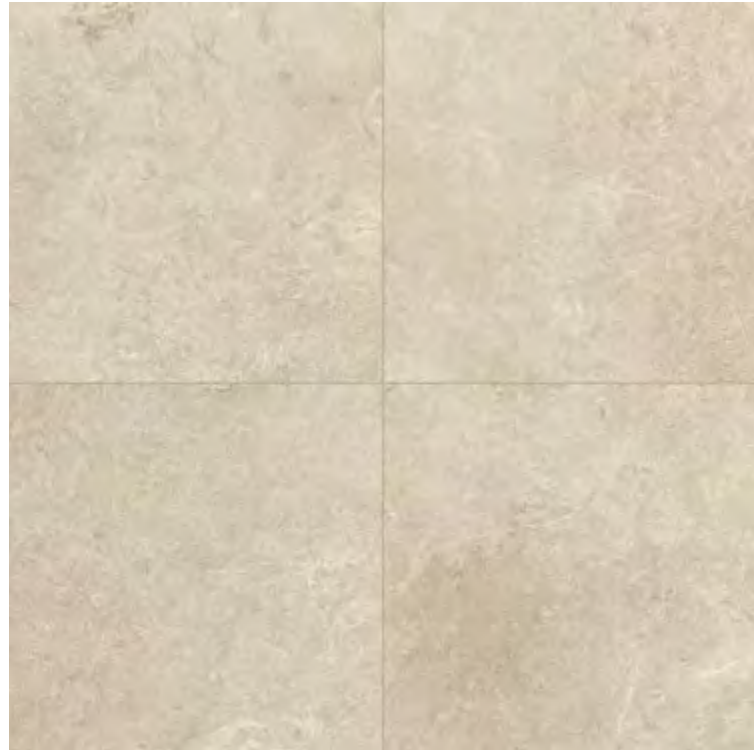

SUPERFICIE NATURALE / BORDO RETTIFICATO		A+B R10	
60x120 - 24"x47"	9	995563	93
60x60 - 24"x24"	9	100551	69
30x60 - 12"x24"	9	100561	63
15x60 - 6"x24" on demand ≥ 1 pl	9	100571	163

SUPERFICIE GRIP / BORDO RETTIFICATO		A+B+C R11	
30x60 - 12"x24"	9	100566	63

stone effect - effetto pietra - effet pierre - Steineffekt - efecto piedra

Mosaics - Mosaici - Mosaïques - Mosaik - Mosaicos

SUPERFICIE NATURALE		A+B	
MOSAICO 4,7x4,7 - 1,8"x1,8" SU RETE 30x30 - 12"x12"			
GERUSALEM STONE	9	100661	253

SUPERFICIE NATURALE		A+B+C	
MOSAICO 2,5x2,5 - 1"x1" SU FOGLIO 30x30 - 12"x12"			
GERUSALEM STONE	9	100667	297

Special pieces - Pezzi speciali - Pièces spéciales - Formstücke - Piezas especiales

<b>BATTISCOPA 5,4x60 - 2,1"x24"</b>	<b>GRADONE COSTA RETTA 120x33 - 47"x13"</b>	<b>GRADONE ANGOLARE COSTA RETTA DX/SX 120x33 - 47"x13"</b>
NATT. RETT. ● 10	NATURALE RETT. ● 333	NATURALE RETT. ● 345
<b>GRADINO 30x60 - 12"x24"</b>	<b>ELEMENTO ELLE MONOLITICO 15x30x4 - 6"x12" x1,5" *</b>	<b>LISTELLO ALLUMINIO 1,5x100 - 0,6"x40"</b>
NATT. RETT. ● 55	GRIP ● 22	33399 ● 22

Minimum order 5 pieces /  
Ordine minimo 5 pz /  
Commande minimum 5 pièces /  
Mindestbestellmenge 5 Stück /  
Pedido mínimo 5 piezas

Packaging - Imballi - Emballages - Verpackung - Embalajes

FLOOR TILES / PAVIMENTI / PAVIMENTS / GRUNDFLEISEN / AZULEJOS							
	sizes formati formats Formate formatos	60x120 24"x47"	60x60 24"x24"	30x60 12"x24"	15x60 6"x24"	30x30 4,7x4,7 12"x12" 1,8"x1,8" mosaico	30x30 2,5x2,5 12"x12" 1"x1" mosaico
	boxes colli boîtes Kartons cajas	pc.	2	3	6	14	11 fogli
		m <sup>2</sup>	1,44	1,08	1,08	1,26	1
		kg	31,0	22,5	22,4	23,5	20,30
	pallets pallet palette Paletts paletas	colli	35	40	48	50	
		m <sup>2</sup>	50,4	43,2	51,8	63	
		kg	1085	900	1075	1175	

SPECIAL PIECES / PEZZI SPECIALI / PIÈCES SPÉCIALES / FORMSTÜCKE / PIEZAS ESPECIALES							
	sizes formati formats Formate formatos	5,4x60 2,1"x24" battiscopa	30x60 12"x24" gradino	33x120 13"x47" gradone costa retta	33x120 13"x47" gradone angolare costa retta	15x30x4 6"x12" x1,5" elemento elle monolitico	1,5x100 0,6"x40" listello alluminio
	boxes colli boîtes Kartons cajas	pc.	14	1	1	1	6
		ml	8,4	0,6	1,2	1,2	1,8
		kg	11,0	3,5	11,2	11,7	8,1

Slip - Scivolosità - Glissance - Rutschwert - Adherencia

	Standard Norma Standard   Norm   Norme   Norme	Natural Surface Superficie Natural   Surface Naturelle Natur Oberflächen   Superficie Natural	Grip Surface Superficie Grip   Surface Grip Grip Oberflächen   Superficie Grip	Lapped Surface Superficie Lappata   Surface Rodée Geläpft Oberflächen   Superficie Bruñida
	B.C.R.A. (D.M.I. n. 236 μ>0,4)	> 0,40	> 0,40	-
	ANSI A 326.3 (DCOF WET >0,42)	> 0,42	> 0,42	-
	DIN EN 16165 ANNEX B	R10	R11	-
	DIN EN 16165 ANNEX A	A+B A+B MOSAICO 4,7x4,7 A+B+C MOSAICO 2,5x2,5	A+B+C	-
	BS EN 16165 ANNEX C	-	≥ 36 Dry / ≥ 36 Wet	-
	AS 4586	-	Class P4	-

# Index

- The Company
- Technology
- Sizes
- Thicknesses
- Surfaces
- Porcelain stoneware
- Ecologycare
- Certifications
- Quality and Safety
- Ceramic of Italy
- Fincibec Group
- Campus
- Engineering
- Pools & Wellness
- Facades
- Raised Flooring
- Technical Specifications

## Contents by collection

- |           |                        |
|-----------|------------------------|
| Archè     | Geobrick               |
| Ashley    | Graphis                |
| Azimuth   | On Stage               |
| Blade     | Pietra Castello        |
| Charisma  | <b>Pietre Naturali</b> |
| Dicta     | Tradition              |
| Dolomite  | Transalp               |
| Esprit    | Woodtime               |
| Evolution | Yukon                  |
| Gamut     | Major                  |

## Contents by effect

- WOOD - Legno
- MARBLE - Marmo
- STONE - Pietra
- CONCRETE - Cemento

## Color Index

Color Index Major 20mm

# Tradition

Fine porcelain stoneware - Gres fine porcellanato  
Grès cérame fin - Feinsteinzeug - Gres fine porcelánico

download  
catalogue



Colours - Colori  
Couleurs - Farben - Colores

Travertin Beige

Culture

Rituel

Sizes - Formati  
Formats - Formaten - Formatos

120x120 cm  
60x120 cm  
80x80 cm  
60x60 cm  
30x60 cm  
30x30 cm  
10x30 cm

Thicknesses - Spessori  
Epaisseurs - Dicken - Espesores

9 mm

Surfaces - Superfici  
Surfaces - Oberflächen - Superficies

Natural - Naturale  
Naturelle - Natur - Natural

Brushed - Molata  
Adouci - Geschliffen - Molida

Grip

Edges - Bordi  
Bordes - Kanten - Bordes

Natural - Naturale  
Naturel - Natur - Natural

Rectified - Rettificato  
Rectifié - Rektifiziert - Rectificado

20mm  
**MAJOR**  
50x100 cm  
PAG. 188

ISO 13006 Bla - EN 14411/G  
Fully-resistant flooring  
Pavimenti a resistenza totale  
Sols à résistance totale - Absolut widerständige  
Fußböden - Pavimentos de resistencia total



**c4**  
MOLATA  
Floor tiles recommended for medium traffic areas.  
Piastrelle da pavimento consigliate per calpestio medio.  
Carreaux de sol recommandés pour un trafic piétonnier moyen.  
Bodenfliesen, empfohlen für mittlere Beanspruchung.  
Baldosas de suelo recomendadas para el tránsito medio.

**c5**  
NATURALE  
GRIP  
Floor tiles recommended for heavy uses.  
Piastrelle da pavimento consigliate per calpestio intenso.  
Carreaux de sol recommandés pour un trafic piétonnier intense.  
Bodenfliesen, empfohlen für intensive Beanspruchung.  
Baldosas de suelo recomendadas para tránsito intenso.

## Index

The Company  
Technology  
Sizes  
Thicknesses  
Surfaces  
Porcelain stoneware  
Ecologycare  
Certifications  
Quality and Safety  
Ceramic of Italy  
Fincibec Group  
Campus  
Engineering  
Pools & Wellness  
Facades  
Raised Flooring  
Technical Specifications

### Contents by collection

Archè	Geobrick
Ashley	Graphis
Azimuth	On Stage
Blade	Pietra Castello
Charisma	Pietre Naturali
Dicta	<b>Tradition</b>
Dolomite	Transalp
Esprit	Woodtime
Evolution	Yukon
Gamut	Major

### Contents by effect

WOOD - Legno  
MARBLE - Marmo  
STONE - Pietra  
CONCRETE - Cemento

### Color Index

Color Index Major 20mm

**V2**  
Light variation - Lieve variazione  
Variation légère  
Gerinde Farbunterschied  
Variación escasa

stone effect - effetto pietra - effet pierre - Steineffekt - efecto piedra

- The Company
- Technology
- Sizes
- Thicknesses
- Surfaces
- Porcelain stoneware
- Ecologycare
- Certifications
- Quality and Safety
- Ceramic of Italy
- Fincibec Group
- Campus
- Engineering
- Pools & Wellness
- Facades
- Raised Flooring
- Technical Specifications

## Contents by collection

- |           |                  |
|-----------|------------------|
| Archè     | Geobrick         |
| Ashley    | Graphis          |
| Azimuth   | On Stage         |
| Blade     | Pietra Castello  |
| Charisma  | Pietre Naturali  |
| Dicta     | <b>Tradition</b> |
| Dolomite  | Transalp         |
| Esprit    | Woodtime         |
| Evolution | Yukon            |
| Gamut     | Major            |

## Contents by effect

- WOOD - Legno
- MARBLE - Marmo
- STONE - Pietra
- CONCRETE - Cemento

## Color Index

Color Index Major 20mm

## Travertin Beige



### SUPERFICIE NATURALE / BORDO RETTIFICATO R10

▲ 120x120 - 47"x47"	9	113064	127
60x120 - 24"x47"	9	113077	93
80x80 - 31,5"x31,5"	9	113173	93
60x60 - 24"x24"	9	113186	69
30x60 - 12"x24"	9	113199	63
30x30 - 12"x12"	9	114783	73

### SUPERFICIE NATURALE / BORDO NATURALE R10

MATTONCINO 10x30 - 4"x12"	9	113863	163
---------------------------	---	--------	-----

### SUPERFICIE GRIP / BORDO RETTIFICATO A+B+C R11

60x60 - 24"x24"	9	113798	69
30x60 - 12"x24"	9	113800	63
30x30 - 12"x12"	9	114188	63

### SUPERFICIE MOLATA / BORDO RETTIFICATO

▲ 120x120 - 47"x47"	9	113072	163
60x120 - 24"x47"	9	113084	109
80x80 - 31,5"x31,5"	9	113178	109
60x60 - 24"x24"	9	113191	83
30x60 - 12"x24"	9	113204	73
30x30 - 12"x12"	9	114992	83

## Culture



### SUPERFICIE NATURALE / BORDO RETTIFICATO R10

▲ 120x120 - 47"x47"	9	113063	127
60x120 - 24"x47"	9	113076	93
80x80 - 31,5"x31,5"	9	113088	93
60x60 - 24"x24"	9	113185	69
30x60 - 12"x24"	9	113198	63
30x30 - 12"x12"	9	114987	73

### SUPERFICIE NATURALE / BORDO NATURALE R10

MATTONCINO 10x30 - 4"x12"	9	113862	163
---------------------------	---	--------	-----

### SUPERFICIE GRIP / BORDO RETTIFICATO A+B+C R11

60x60 - 24"x24"	9	113797	69
30x60 - 12"x24"	9	113799	63
30x30 - 12"x12"	9	114187	63

### SUPERFICIE MOLATA / BORDO RETTIFICATO

▲ 120x120 - 47"x47"	9	113069	163
60x120 - 24"x47"	9	113081	109
80x80 - 31,5"x31,5"	9	113177	109
60x60 - 24"x24"	9	113190	83
30x60 - 12"x24"	9	113203	73
30x30 - 12"x12"	9	114995	83

▲ cm 120x120 split pallet surcharge 40 € each - lightened stand containing 95 €  
cm 120x120 addebito frazione di paletta 40 € - cavalla alleggerita 95 €  
cm 120x120 surtaxe contremarque 40 € - chevalet allégé 95 €  
cm 120x120 Aufpreis Teilpalette 40 € - leichter Ständer 95 €  
cm 120x120 recargo fracción de paleta 40 € - soporte ligero 95 €

## Rituel

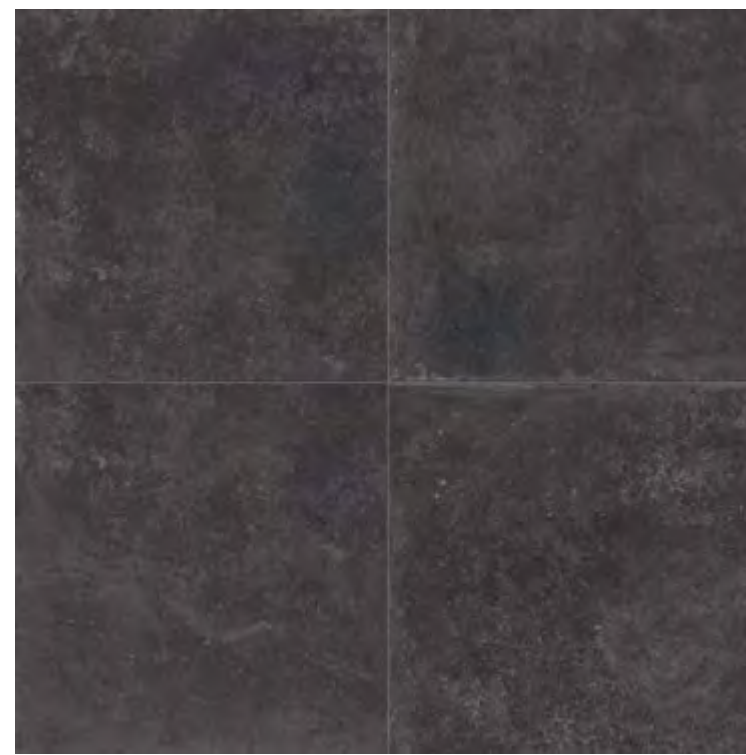

### SUPERFICIE NATURALE / BORDO RETTIFICATO R10

▲ 120x120 - 47"x47"	9	113066	127
60x120 - 24"x47"	9	113079	93
80x80 - 31,5"x31,5"	9	113175	93
60x60 - 24"x24"	9	113188	69
30x60 - 12"x24"	9	113201	63
30x30 - 12"x12"	9	114990	73

### SUPERFICIE NATURALE / BORDO NATURALE R10

MATTONCINO 10x30 - 4"x12"	9	113864	163
---------------------------	---	--------	-----

### SUPERFICIE MOLATA / BORDO RETTIFICATO

▲ 120x120 - 47"x47"	9	113074	163
60x120 - 24"x47"	9	113086	109
80x80 - 31,5"x31,5"	9	113180	109
60x60 - 24"x24"	9	113196	83
30x60 - 12"x24"	9	113208	73
30x30 - 12"x12"	9	114996	83

▲ cm 120x120 split pallet surcharge 40 € each - lightened stand containing 95 €  
cm 120x120 addebito frazione di paletta 40 € - cavalla alleggerita 95 €  
cm 120x120 surtaxe contremarque 40 € - chevalet allégé 95 €  
cm 120x120 Aufpreis Teilpalette 40 € - leichter Ständer 95 €  
cm 120x120 recargo fracción de paleta 40 € - soporte ligero 95 €

SUPERFICIE NATURALE		A+B	
MOSAICO 4,7x4,7 - 1,8"x1,8" SU RETE 30x30 - 12"x12"			
TRAVERTIN BEIGE	9	114107	253
CULTURE	9	114106	253
RITUEL	9	114108	199

SUPERFICIE NATURALE		A+B+C	
MOSAICO 2,5x2,5 - 1"x1" SU FOGLIO 30x30 - 12"x12"			
TRAVERTIN BEIGE	9	115675	297
CULTURE	9	115676	297

Special pieces - Pezzi speciali - Pièces spéciales - Formstücke - Piezas especiales

<b>BATTISCOPA 5,4x60 - 2,1"x24"</b>			
NATURALE RETT.	●	10	
MOLATA RETT.	●	12	
<b>GRADINO 30x60 - 12"x24"</b>			
NATURALE RETT.	●	55	
GRIP RETT.	●	55	
<b>GRADONE COSTA RETTA 120x33 - 47"x13"</b>			
NATURALE RETT.	●	333	
MOLATA RETT.	●	337	
<b>GRADONE ANGOLARE COSTA RETTA DX/SX 120x33 - 47"x13"</b>			
NATURALE RETT.	●	345	
MOLATA RETT.	●	349	
<b>ELEMENTO ELLE MONOLITICO 15x30x4 - 6"x12" x1,5"</b>			
NATURALE RETT.	●	22	
GRIP	●		

Minimum order 5 pieces /  
Ordine minimo 5 pz /  
Commande minimum 5 pièces /  
Mindestbestellmenge 5 Stück /  
Pedido mínimo 5 piezas

Packaging - Imballi - Emballages - Verpackung - Embalajes

FLOOR TILES / PAVIMENTI / PAVIMENTS / GRUNDFLIESEN / AZULEJOS										
	sizes formati formats Formate formatos	120x120 47"x47"	60x120 24"x47"	80x80 31,5"x31,5"	60x60 24"x24"	30x60 12"x24"	30x30 12"x12"	10x30 4"x12" mattoncino	30x30 4,7x4,7 12"x12" 1,8"x1,8" mosaico	30x30 2,5x2,5 12"x12" 1"x1" mosaico
	pc.	2	2	2	3	6	13	30	11 fogli	11 fogli
	m <sup>2</sup>	2,88	1,44	1,28	1,08	1,08	1,17	0,9	1	1
	kg	58,0	31,0	26,2	22,5	22,5	23,0	18,1	20,3	20,3
	colli	20	35	40	40	48	48	48		
	m <sup>2</sup>	57,6	50,4	51,2	43,2	51,8	56,2	43,2		
	kg	1160	1085	1048	900	1080	1104	869		

SPECIAL PIECES / PEZZI SPECIALI / PIÈCES SPÉCIALES / FORMSTÜCKE / PIEZAS ESPECIALES					
sizes formati formats Formate formatos	5,4x60 2,1"x24" battiscopa	30x60 12"x24" gradino	33x120 13"x47" gradone costa retta	33x120 13"x47" gradone angolare costa retta	15x30x4 6"x12" x1,5" elemento elle monolitico
pc.	14	1	1	1	6
ml	8,4	0,6	1,2	1,2	1,8
kg	11,0	3,5	11,2	11,7	8,1

Slip - Scivolosità - Glisance - Rutschwert - Adherencia

	Standard Norma Standard   Norm   Norme   Norme	Natural Surface Superficie Natural   Surface Naturelle Natur Oberflächen   Superficie Natural	Grip Surface Superficie Grip   Surface Grip Grip Oberflächen   Superficie Grip	Brushed Surface Superficie Molata   Surface Adouci Geschliffen Oberflächen   Superficie Molida
	B.C.R.A. (D.M.I. n. 236 μ>0,4)	> 0,40	> 0,40	-
	ANSI A 326.3 (DCOF WET >0,42)	> 0,42	> 0,42	> 0,42
	DIN EN 16165 ANNEX B	R10	R11	-
	DIN EN 16165 ANNEX A	A+B MOSAICO 4,7x4,7 A+B+C MOSAICO 2,5x2,5	A+B+C	-
	BS EN 16165 ANNEX C	-	≥ 36 Dry / ≥ 36 Wet	-
	AS 4586	-	Class P4	-

stone effect - effetto pietra - effet pierre - Steineffekt - efecto piedra



# Index

- The Company
- Technology
- Sizes
- Thicknesses
- Surfaces
- Porcelain stoneware
- Ecologycare
- Certifications
- Quality and Safety
- Ceramic of Italy
- Fincibec Group
- Campus
- Engineering
- Pools & Wellness
- Facades
- Raised Flooring
- Technical Specifications

## Contents by collection

- |           |                  |
|-----------|------------------|
| Archè     | Geobrick         |
| Ashley    | Graphis          |
| Azimuth   | On Stage         |
| Blade     | Pietra Castello  |
| Charisma  | Pietre Naturali  |
| Dicta     | <b>Tradition</b> |
| Dolomite  | Transalp         |
| Esprit    | Woodtime         |
| Evolution | Yukon            |
| Gamut     | Major            |

## Contents by effect

- WOOD - Legno
- MARBLE - Marmo
- STONE - Pietra
- CONCRETE - Cemento

## Color Index

Color Index Major 20mm





Photo by Arran L. for Unsplash

Fine porcelain stoneware - Gres fine porcellanato  
Grès cérame fin - Feinsteinzeug - Gres fine porcelánico

## CONCRETE EFFECT - EFFETTO CEMENTO

effet concret - konkrete Wirkung - efecto concreto

pag. 144 **Gamut**  
pag. 152 **Esprit**  
pag. 160 **Blade**  
pag. 168 **Graphis**

# Index

The Company  
Technology  
Sizes  
Thicknesses  
Surfaces  
Porcelain stoneware  
Ecologycare  
Certifications  
Quality and Safety  
Ceramic of Italy  
Fincibec Group  
Campus  
Engineering  
Pools & Wellness  
Facades  
Raised Flooring  
Technical Specifications

### > Contents by collection

Archè	Geobrick
Ashley	Graphis
Azimuth	On Stage
Blade	Pietra Castello
Charisma	Pietre Naturali
Dicta	Tradition
Dolomite	Transalp
Esprit	Woodtime
Evolution	Yukon
Gamut	Major

### > Contents by effect

WOOD - Legno  
MARBLE - Marmo  
STONE - Pietra  
**CONCRETE - Cemento**

### > Color Index

Color Index Major 20mm

# Gamut

Fine porcelain stoneware - Gres fine porcellanato  
Grès cérame fin - Feinsteinzeug - Gres fine porcelánico

download  
catalogue



watch  
the video



Colours - Colori  
Couleurs - Farben - Coiores

Tune

Sphere

Power

Swing

Intensity

Diapason

**V2** Light variation - Lieve variazione  
Variation légère  
Gerinde Farbunterschied  
Variación escasa

Sizes - Formati  
Formats - Formaten - Formatos

120x120 cm  
60x120 cm  
80x80 cm  
60x60 cm

Thicknesses - Spessori  
Epaisseurs - Dicken - Espesores

9 mm

Surfaces - Superfici  
Surfaces - Oberflächen - Superficies

Natural - Naturale  
Naturelle - Natur - Natural

Soft

Edges - Bordi  
Bordes - Kanten - Bordes

Rectified - Rettificato  
Rectifié - Rektifiziert - Rectificado

ISO 13006 Bla - EN 14411/G  
Fully-resistant flooring  
Pavimenti a resistenza totale  
Sols à résistance totale - Absolut widerständige  
Fußböden - Pavimentos de resistencia total



**c5** Floor tiles recommended for heavy uses.  
Piastrille da pavimento consigliate per calpestio intenso.  
Carreaux de sol recommandés pour un trafic piétonnier intense.  
Bodenfliesen, empfohlen für intensive Beanspruchung.  
Baldosas de suelo recomendadas para tránsito intenso.

concrete effect - effetto cemento - effet concret - effekt beton - konkrete wirkung - efecto concreto

## Index

The Company  
Technology  
Sizes  
Thicknesses  
Surfaces  
Porcelain stoneware  
Ecologycare  
Certifications  
Quality and Safety  
Ceramic of Italy  
Fincibec Group  
Campus  
Engineering  
Pools & Wellness  
Facades  
Raised Flooring  
Technical Specifications

### > Contents by collection

Archè	Geobrick
Ashley	Graphis
Azimuth	On Stage
Blade	Pietra Castello
Charisma	Pietre Naturali
Dicta	Tradition
Dolomite	Transalp
Esprit	Woodtime
Evolution	Yukon
<b>Gamut</b>	Major

### > Contents by effect

WOOD - Legno  
MARBLE - Marmo  
STONE - Pietra  
CONCRETE - Cemento

### > Color Index

Color Index Major 20mm

## Tune

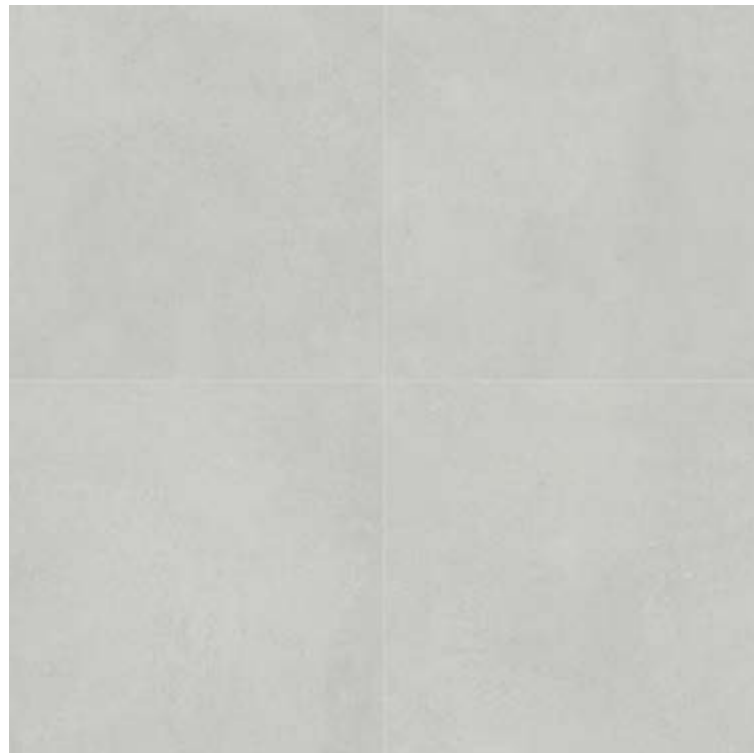

SUPERFICIE NATURALE / BORDO RETTIFICATO		A+B R10	
▲ 120x120 - 47"x47"	9	136575	127
60x120 - 24"x47"	9	136667	93
80x80 - 31,5"x31,5"	9	137320	93
60x60 - 24"x24"	9	137312	69

SUPERFICIE SOFT / BORDO RETTIFICATO		R9	
60x120 - 24"x47"	9	138624	93
80x80 - 31,5"x31,5"	9	138629	93

## Sphere

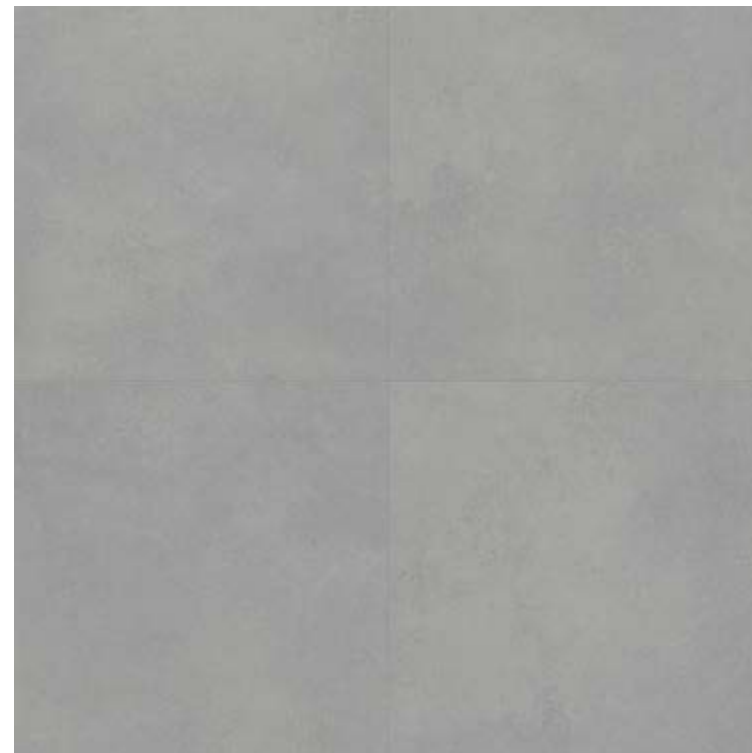

SUPERFICIE NATURALE / BORDO RETTIFICATO		A+B R10	
▲ 120x120 - 47"x47"	9	136570	127
60x120 - 24"x47"	9	136656	93
80x80 - 31,5"x31,5"	9	137315	93
60x60 - 24"x24"	9	137305	69

SUPERFICIE SOFT / BORDO RETTIFICATO		R9	
60x120 - 24"x47"	9	138620	93
80x80 - 31,5"x31,5"	9	138627	93

▲ cm 120x120 split pallet surcharge 40 € each - lightened stand containing 95 €  
cm 120x120 addebito frazione di paletta 40 € - cavalla alleggerita 95 €  
cm 120x120 surtaxe contremarque 40 € - chevalet allégé 95 €  
cm 120x120 Aufpreis Teilpalette 40 € - leichter Ständer 95 €  
cm 120x120 recargo fracción de paleta 40 € - soporte ligero 95 €

## Power



SUPERFICIE NATURALE / BORDO RETTIFICATO		A+B R10	
▲ 120x120 - 47"x47"	9	136572	127
60x120 - 24"x47"	9	136658	93
80x80 - 31,5"x31,5"	9	137317	93
60x60 - 24"x24"	9	137308	69

SUPERFICIE SOFT / BORDO RETTIFICATO		R9	
60x120 - 24"x47"	9	138621	93
80x80 - 31,5"x31,5"	9	138626	93

## Swing



SUPERFICIE NATURALE / BORDO RETTIFICATO		A+B R10	
▲ 120x120 - 47"x47"	9	136574	127
60x120 - 24"x47"	9	136666	93
80x80 - 31,5"x31,5"	9	137319	93
60x60 - 24"x24"	9	137311	69

SUPERFICIE SOFT / BORDO RETTIFICATO		R9	
60x120 - 24"x47"	9	138623	93
80x80 - 31,5"x31,5"	9	138628	93

▲ cm 120x120 split pallet surcharge 40 € each - lightened stand containing 95 €  
cm 120x120 addebito frazione di paletta 40 € - cavalla alleggerita 95 €  
cm 120x120 surtaxe contremarque 40 € - chevalet allégé 95 €  
cm 120x120 Aufpreis Teilpalette 40 € - leichter Ständer 95 €  
cm 120x120 recargo fracción de paleta 40 € - soporte ligero 95 €

# Index

- The Company
- Technology
- Sizes
- Thicknesses
- Surfaces
- Porcelain stoneware
- Ecologycare
- Certifications
- Quality and Safety
- Ceramic of Italy
- Fincibec Group
- Campus
- Engineering
- Pools & Wellness
- Facades
- Raised Flooring
- Technical Specifications

## Contents by collection

- |              |                 |
|--------------|-----------------|
| Archè        | Geobrick        |
| Ashley       | Graphis         |
| Azimuth      | On Stage        |
| Blade        | Pietra Castello |
| Charisma     | Pietre Naturali |
| Dicta        | Tradition       |
| Dolomite     | Transalp        |
| Esprit       | Woodtime        |
| Evolution    | Yukon           |
| <b>Gamut</b> | Major           |

## Contents by effect

- WOOD - Legno
- MARBLE - Marmo
- STONE - Pietra
- CONCRETE - Cemento

## Color Index

Color Index Major 20mm

## Intensity



SUPERFICIE NATURALE / BORDO RETTIFICATO		A+B R10	
60x120 - 24"x47"	9	136665	93
60x60 - 24"x24"	9	137310	69

SUPERFICIE SOFT / BORDO RETTIFICATO		R9	
60x120 - 24"x47"	9	138622	93

## Diapason

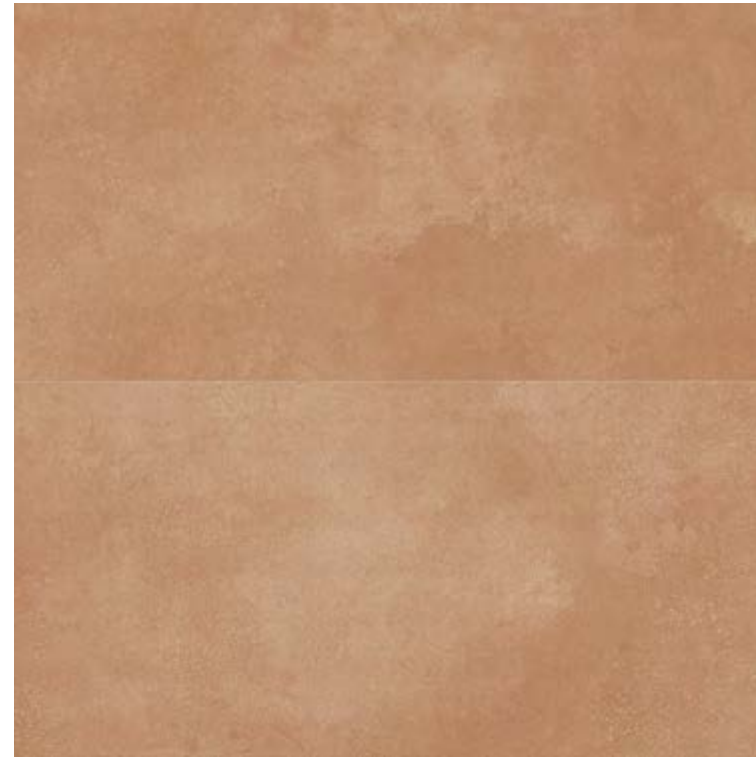

SUPERFICIE NATURALE / BORDO RETTIFICATO		A+B R10	
60x120 - 24"x47"	9	137368	93
60x60 - 24"x24"	9	137314	69

SUPERFICIE SOFT / BORDO RETTIFICATO		R9	
60x120 - 24"x47"	9	138625	93

## Decors - Decori - Eléments décoratifs - Dekore - Decoraciones

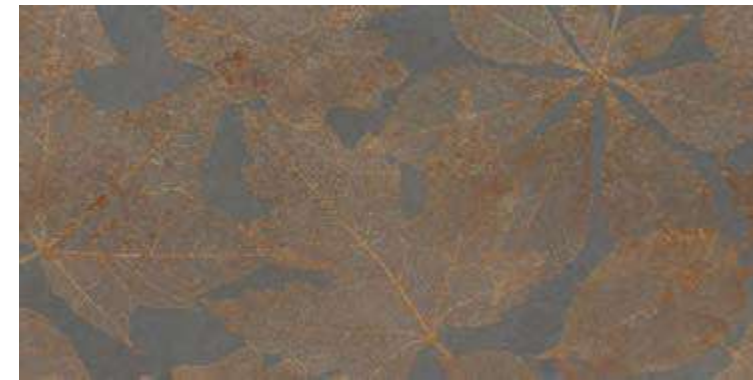

SUPERFICIE NATURALE / BORDO RETTIFICATO		R9	
LEAF POWER 60x120 - 24"x47"	9	137299	143



SUPERFICIE NATURALE / BORDO RETTIFICATO		R9	
LEAF SPHERE 60x120 - 24"x47"	9	138535	143



SUPERFICIE NATURALE / BORDO RETTIFICATO		R9	
ATTRACTION 60x120 - 24"x47"	9	138536	143

# Index

- The Company
- Technology
- Sizes
- Thicknesses
- Surfaces
- Porcelain stoneware
- Ecologycare
- Certifications
- Quality and Safety
- Ceramic of Italy
- Fincibec Group
- Campus
- Engineering
- Pools & Wellness
- Facades
- Raised Flooring
- Technical Specifications

## > Contents by collection

- |              |                 |
|--------------|-----------------|
| Archè        | Geobrick        |
| Ashley       | Graphis         |
| Azimuth      | On Stage        |
| Blade        | Pietra Castello |
| Charisma     | Pietre Naturali |
| Dicta        | Tradition       |
| Dolomite     | Transalp        |
| Esprit       | Woodtime        |
| Evolution    | Yukon           |
| <b>Gamut</b> | Major           |

## > Contents by effect

- WOOD - Legno
- MARBLE - Marmo
- STONE - Pietra
- CONCRETE - Cemento

## > Color Index

Color Index Major 20mm

Fine porcelain stoneware - Gres fine porcellanato  
Grès cérame fin - Feinsteinzeug - Gres fine porcelánico

Mosaics - Mosaici - Mosaïques - Mosaik - Mosaicos

SUPERFICIE NATURALE		A+B	
<b>MOSAICO 4,7x4,7 - 1,8"x1,8" SU RETE 30x30 - 12"x12"</b>			
TUNE	9	137424	253
SPHERE	9	137419	253
POWER	9	137421	253
SWING	9	137423	253
INTENSITY	9	137422	253
DIAPASON	9	137426	253

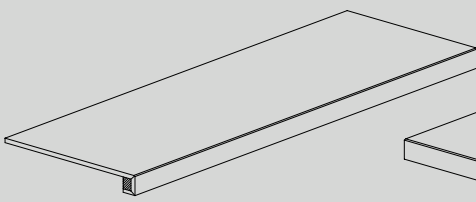
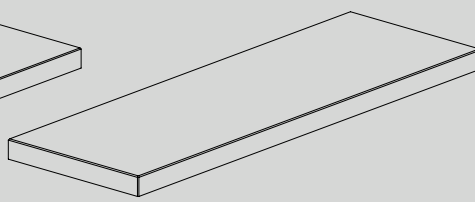

SUPERFICIE NATURALE		A+B	
<b>MOSAICO ESAGONETTA SU RETE 30x34 - 12"x13"</b>			
TUNE	9	138912	313
SPHERE	9	138907	313
POWER	9	138908	313
SWING	9	138910	313
INTENSITY	9	138909	313
DIAPASON	9	138913	313

Special pieces - Pezzi speciali - Pièces spéciales - Formstücke - Piezas especiales

	<b>*BATTISCOPA 7,1x120 - 3"x47"</b>	
NATURALE RETT.	● 19	
<b>BATTISCOPA 5,4x60 - 2,1"x24"</b>		
NATURALE RETT.	● 10	
	<b>GRADONE COSTA RETTA 120x33 - 47"x13"</b>	
NATURALE RETT.	● 333	
<b>SOFT RETT.</b>	● 333	
	<b>GRADONE ANGOLARE COSTA RETTA DX/SX 120x33 - 47"x13"</b>	
NATURALE RETT.	● 345	
<b>SOFT RETT.</b>	● 345	

\* Minimum order 210 pieces / Ordine minimo 210 pz / Commande minimum 210 pièces / Mindestbestellmenge 210 Stück / Pedido mínimo 210 piezas

Packaging - Imballi - Emballages - Verpackung - Embalajes

FLOOR TILES / PAVIMENTI / PAVIMENTS / GRUNDFLIESEN / AZULEJOS							
sizes formati formats Formate formatos		120x120 47"x47"	60x120 24"x47"	80x80 31,5"x31,5"	60x60 24"x24"	30x30 12"x12" mosaico	30x34 12"x13" mosaico esagonetta
	boxes colli boîtes Kartons cajas	pc.	2	2	2	3	11 fogli
		m <sup>2</sup>	2,88	1,44	1,28	1,08	1
		kg	58,0	31,0	26	22,5	20,3
	pallets pallet palette Paletts paletas	colli	20	35	40	40	
		m <sup>2</sup>	57,6	50,4	51,2	43,2	
		kg	1160	1085	1033	900	

SPECIAL PIECES / PEZZI SPECIALI / PIÈCES SPÉCIALES / FORMSTÜCKE / PIEZAS ESPECIALES					
sizes formati formats Formate formatos		7,1x120 3"x47" battiscopa	5,4x60 2,1"x24" battiscopa	33x120 13"x47" gradone costa retta	33x120 13"x47" gradone angolare costa retta
	boxes colli boîtes Kartons cajas	pc.	6	14	1
		ml	7,2	8,4	1,2
		kg	10,2	11,0	11,2

Slip - Scivolosità - Glisance - Rutschwert - Adherencia

	Standard Norma Standard   Norm   Norme   Norme	Natural Surface Superficie Natural   Surface Naturelle Natur Oberflächen   Superficie Natural	Soft Surface Superficie Soft   Surface Soft Soft Oberflächen   Superficie Soft	Natural Surface Decors Decori Superficie Natural   Eléments décoratifs Surface Naturelle   Dekore Natur Oberflächen   Decoraciones Superficie Natural
	B.C.R.A. (D.M.I. n. 236 μ>0,4)	> 0,40	> 0,40	-
	ANSI A 326.3 (DCOF WET >0,42)	> 0,42	> 0,42	-
	DIN EN 16165 ANNEX B	R10	R9	R9
	DIN EN 16165 ANNEX A	A+B / A+B+C MOSAICO 4,7x4,7	-	-
	BS EN 16165 Annex C	≥ 36 Dry / ≥ 36 Wet	-	-
	AS 4586	Class P3	-	-

concrete effect - effetto cemento - effet concret - konkrete wirkung - efecto concreto



# Index

- The Company
- Technology
- Sizes
- Thicknesses
- Surfaces
- Porcelain stoneware
- Ecologycare
- Certifications
- Quality and Safety
- Ceramic of Italy
- Fincibec Group
- Campus
- Engineering
- Pools & Wellness
- Facades
- Raised Flooring
- Technical Specifications

## Contents by collection

- |              |                 |
|--------------|-----------------|
| Archè        | Geobrick        |
| Ashley       | Graphis         |
| Azimuth      | On Stage        |
| Blade        | Pietra Castello |
| Charisma     | Pietre Naturali |
| Dicta        | Tradition       |
| Dolomite     | Transalp        |
| Esprit       | Woodtime        |
| Evolution    | Yukon           |
| <b>Gamut</b> | Major           |

## Contents by effect

- WOOD - Legno
- MARBLE - Marmo
- STONE - Pietra
- CONCRETE - Cemento

## Color Index

Color Index Major 20mm

# Esprit

Fine porcelain stoneware - Gres fine porcellanato  
Grès cérame fin - Feinsteinzeug - Gres fine porcelánico

download catalogue

watch the video



Colours - Colori  
Couleurs - Farben - Colores

Stick

Soul

Origin

Ground

Jade

Sharp

Energy

Legend

**V2** **Light variation** - Lieve variazione  
Variation légère  
Gerinde Farbunterschied  
Variación escasa

**V3** **Medium variation** - Media variazione  
Moyenne variation  
Mittlerer Farbunterschied  
Media Variación

ENERGY  
LEGEND

Sizes - Formati  
Formats - Formaten - Formatos

**120x278 cm**  
**(\*120x260 cm)**  
**120x120 cm**  
**60x120 cm**  
**80x80 cm**  
**60x60 cm**  
**30x60 cm**

Thicknesses - Spessori  
Epaisseurs - Dicken - Espesores

**9 mm**  
**7 mm**

Surfaces - Superfici  
Surfaces - Oberflächen - Superficies

**Natural** - Naturale  
Naturelle - Natur - Natural

Edges - Bordi  
Bordes - Kanten - Bordes

**Rectified** - Rettificato  
Rectifié - Rektifiziert - Rectificado

ISO 13006 Bla - EN 14411/G  
**Fully-resistant flooring**  
**Pavimenti a resistenza totale**  
Sols à résistance totale - Absolut widerständige  
Fußböden - Pavimentos de resistencia total



**c4** **Floor tiles recommended for medium traffic areas.**  
Piastrille da pavimento consigliate per calpestio medio.  
Carreaux de sol recommandés pour un trafic piétonnier moyen.  
Bodenfliesen, empfohlen für mittlere Beanspruchung.  
Baldosas de suelo recomendadas para el tránsito medio.

**c5** **Floor tiles recommended for heavy uses.**  
Piastrille da pavimento consigliate per calpestio intenso.  
Carreaux de sol recommandés pour un trafic piétonnier intense.  
Bodenfliesen, empfohlen für intensive Beanspruchung.  
Baldosas de suelo recomendadas para tránsito intenso.

\* **cm 120x260**  
**after after out of stock**  
fino ad esaurimento scorte  
jusqu'à épuisement des stocks  
hasta agotar el stock  
solange der Vorrat reicht

concrete effect - effetto cemento - effet concret - effekt beton - konkrete wirkung - concreto

## Index

- The Company
- Technology
- Sizes
- Thicknesses
- Surfaces
- Porcelain stoneware
- Ecologycare
- Certifications
- Quality and Safety
- Ceramic of Italy
- Fincibec Group
- Campus
- Engineering
- Pools & Wellness
- Facades
- Raised Flooring
- Technical Specifications

## Contents by collection

- |               |                 |
|---------------|-----------------|
| Archè         | Geobrick        |
| Ashley        | Graphis         |
| Azimuth       | On Stage        |
| Blade         | Pietra Castello |
| Charisma      | Pietre Naturali |
| Dicta         | Tradition       |
| Dolomite      | Transalp        |
| <b>Esprit</b> | Woodtime        |
| Evolution     | Yukon           |
| Gamut         | Major           |

## Contents by effect

- WOOD - Legno
- MARBLE - Marmo
- STONE - Pietra
- CONCRETE - Cemento

## Color Index

Color Index Major 20mm

## Stick



SUPERFICIE NATURALE / BORDO RETTIFICATO		A+B R10	
▲ 120x120 - 47"x47"	9	125790	127
60x120 - 24"x47"	9	125771	93
80x80 - 31,5"x31,5"	9	125813	93
60x60 - 24"x24"	9	125797	69
30x60 - 12"x24"	9	125804	63

## Soul

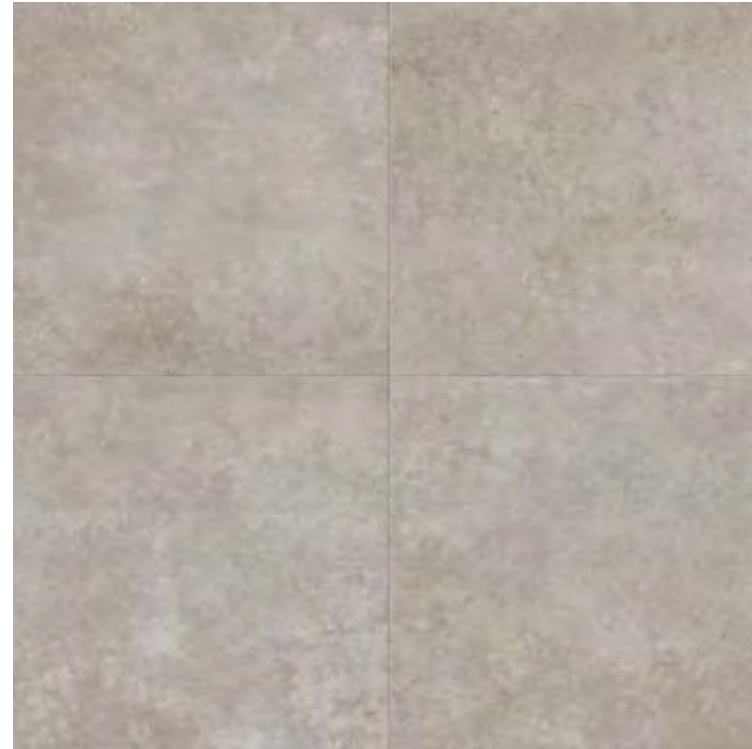

SUPERFICIE NATURALE / BORDO RETTIFICATO		A+B R10	
▲ 120x120 - 47"x47"	9	125792	127
60x120 - 24"x47"	9	125773	93
80x80 - 31,5"x31,5"	9	125815	93
60x60 - 24"x24"	9	125799	69
30x60 - 12"x24"	9	125808	63

▲ cm 120x120 split pallet surcharge 40 € each - lightened stand containing 95 €  
cm 120x120 addebito frazione di paletta 40 € - cavalla alleggerita 95 €  
cm 120x120 surtaxe contremarque 40 € - chevalet allégé 95 €  
cm 120x120 Aufpreis Teilpalette 40 € - leichter Ständer 95 €  
cm 120x120 recargo fracción de paleta 40 € - soporte ligero 95 €

## Origin

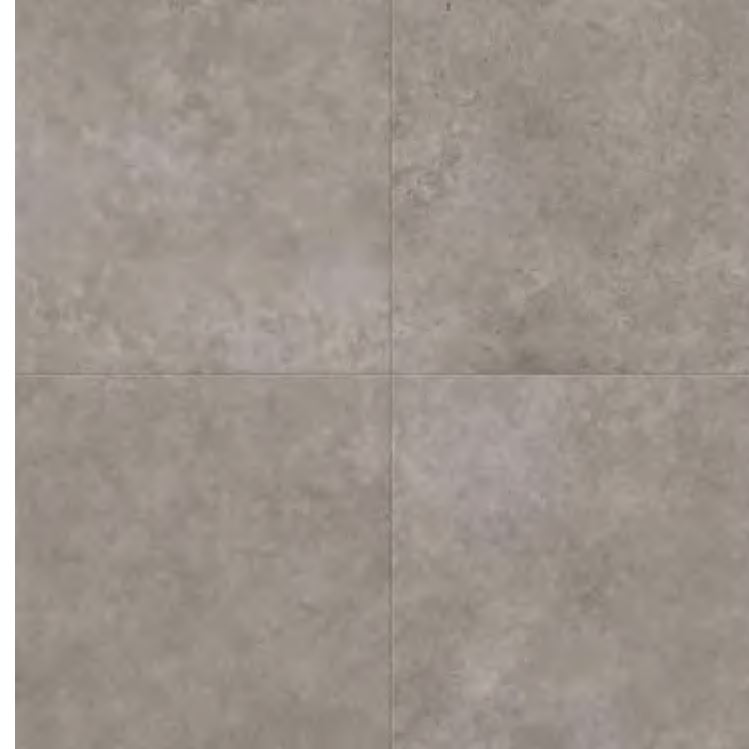

SUPERFICIE NATURALE / BORDO RETTIFICATO		A+B R10	
▲ 120x120 - 47"x47"	9	125789	127
60x120 - 24"x47"	9	125770	93
80x80 - 31,5"x31,5"	9	125811	93
60x60 - 24"x24"	9	125795	69
30x60 - 12"x24"	9	125802	63

\* cm 120x260  
after after out of stock  
fino ad esaurimento scorte  
jusqu'à épuisement des stocks  
hasta agotar el stock  
solange der Vorrat reicht

▲ cm 120x278/120x260 pallet surcharge 160 € - stand containing 295 €  
cm 120x278/120x260 addebito cassa 160 € - cavalla 295 €  
cm 120x278/120x260 surtaxe caisse 160 € - chevalet 295 €  
cm 120x278/120x260 Aufpreis Kiste 160 € - Ständer 295 €  
cm 120x278/120x260 recargo caja 160 € - soporte 295 €

▲ cm 120x120 split pallet surcharge 40 € each - lightened stand containing 95 €  
cm 120x120 addebito frazione di paletta 40 € - cavalla alleggerita 95 €  
cm 120x120 surtaxe contremarque 40 € - chevalet allégé 95 €  
cm 120x120 Aufpreis Teilpalette 40 € - leichter Ständer 95 €  
cm 120x120 recargo fracción de paleta 40 € - soporte ligero 95 €



SUPERFICIE NATURALE / BORDO RETTIFICATO		A+B R10	
*▲ 120x260 - 47"x102"	7	128581	203
▲ 120x278 - 47"x109"	7	138445	203

# Index

The Company  
Technology  
Sizes  
Thicknesses  
Surfaces  
Porcelain stoneware  
Ecologycare  
Certifications  
Quality and Safety  
Ceramic of Italy  
Fincibec Group  
Campus  
Engineering  
Pools & Wellness  
Facades  
Raised Flooring  
Technical Specifications

## Contents by collection

Archè	Geobrick
Ashley	Graphis
Azimuth	On Stage
Blade	Pietra Castello
Charisma	Pietre Naturali
Dicta	Tradition
Dolomite	Transalp
<b>Esprit</b>	Woodtime
Evolution	Yukon
Gamut	Major

## Contents by effect

WOOD - Legno  
MARBLE - Marmo  
STONE - Pietra  
CONCRETE - Cemento

## Color Index

Color Index Major 20mm

## Ground



SUPERFICIE NATURALE / BORDO RETTIFICATO		A+B R10	
▲ 120x120 - 47"x47"	9	125788	127
60x120 - 24"x47"	9	125769	93
80x80 - 31,5"x31,5"	9	125812	93
60x60 - 24"x24"	9	125796	69
30x60 - 12"x24"	9	125803	63

## Jade

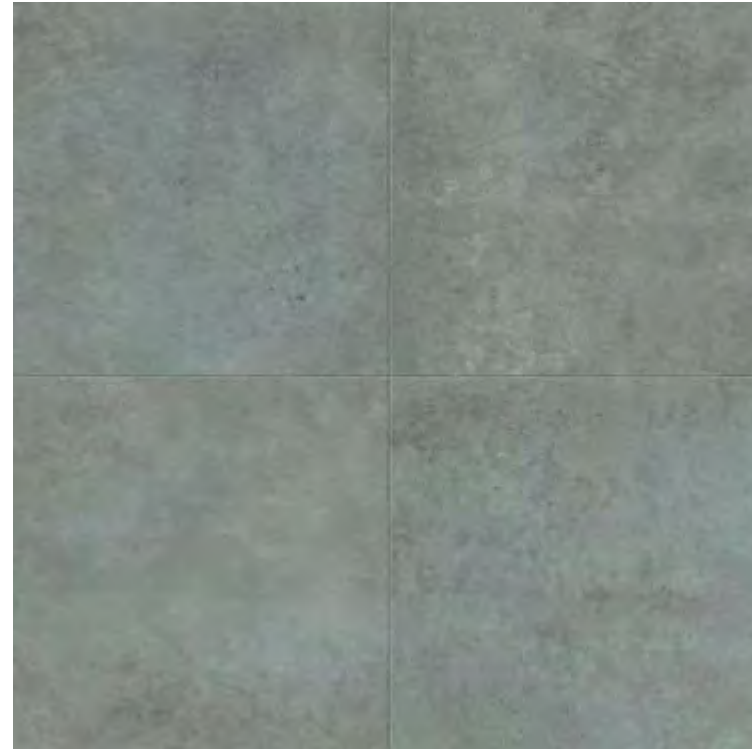

SUPERFICIE NATURALE / BORDO RETTIFICATO		A+B R10	
▲ 120x120 - 47"x47"	9	125793	127
60x120 - 24"x47"	9	125779	93
80x80 - 31,5"x31,5"	9	125817	93
60x60 - 24"x24"	9	125800	69
30x60 - 12"x24"	9	125809	63

## Sharp

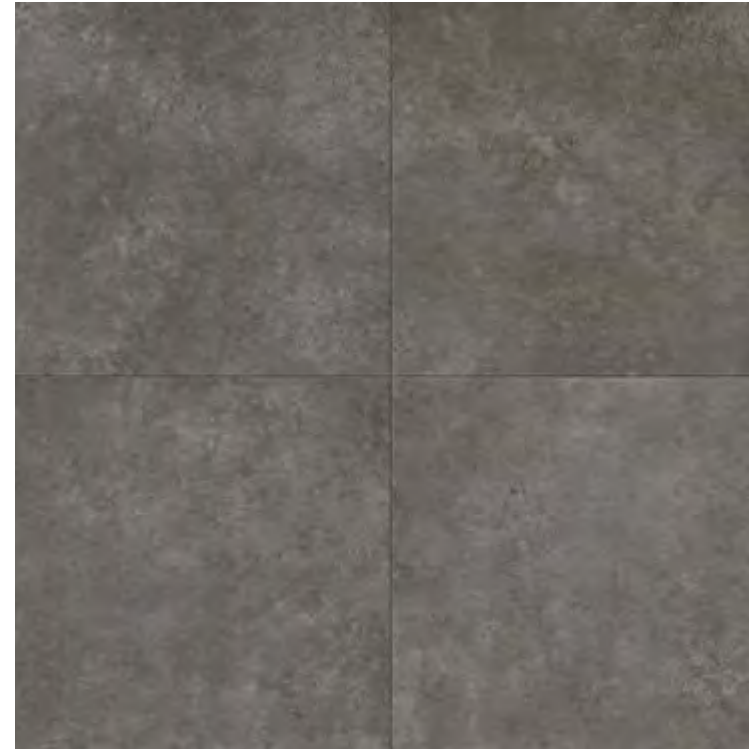

SUPERFICIE NATURALE / BORDO RETTIFICATO		A+B R10	
▲ 120x120 - 47"x47"	9	125791	127
60x120 - 24"x47"	9	125772	93
80x80 - 31,5"x31,5"	9	125814	93
60x60 - 24"x24"	9	125798	69
30x60 - 12"x24"	9	125805	63

## Legend



SUPERFICIE NATURALE / BORDO RETTIFICATO		A+B R10	
60x120 - 24"x47"	9	125787	143

## Mosaics - Mosaici - Mosaiques - Mosaik - Mosaicos

SUPERFICIE NATURALE		A+B	
MOSAICO 4,7x4,7 - 1,8"x1,8" SU RETE 30x30 - 12"x12"			
STICK	9	125860	253
SOUL	9	125862	253
ORIGIN	9	125859	253
GROUND	9	125858	253
JADE	9	125864	253
SHARP	9	125861	253
ENERGY	9	125865	253

SUPERFICIE NATURALE		A+B	
MOSAICO SU RETE 29x29 - 11"x11"			
SWEET JADE	9	130188	33
SWEET ORIGIN	9	130189	33

## Mosaics - Mosaici - Mosaiques - Mosaik - Mosaicos

SUPERFICIE NATURALE		A+B	
WHIM 32x30 - 13"x12"			
GROUND	9	126307	33
SHARP	9	126309	33
JADE/ENERGY (BICOLORE)	9	126310	33
STICK/SOUL/ORIGIN (TRICOLORE)	9	126311	33

SUPERFICIE NATURALE		A+B	
MOTION 39x20 - 15"x8"			
STICK	9	126315	53
SOUL	9	126316	53
ORIGIN	9	126313	53
GROUND	9	126312	53
JADE	9	126318	53
SHARP	9	126314	53
ENERGY	9	126317	53

▲ cm 120x120 split pallet surcharge 40 € each - lightened stand containing 95 €  
cm 120x120 addebito frazione di paletta 40 € - cavalla alleggerita 95 €  
cm 120x120 surtaxe contremarque 40 € - chevalet allégé 95 €  
cm 120x120 Aufpreis Teilpalette 40 € - leichter Ständer 95 €  
cm 120x120 recargo fracción de paleta 40 € - soporte ligero 95 €

▲ cm 120x120 split pallet surcharge 40 € each - lightened stand containing 95 €  
cm 120x120 addebito frazione di paletta 40 € - cavalla alleggerita 95 €  
cm 120x120 surtaxe contremarque 40 € - chevalet allégé 95 €  
cm 120x120 Aufpreis Teilpalette 40 € - leichter Ständer 95 €  
cm 120x120 recargo fracción de paleta 40 € - soporte ligero 95 €

# Index

- The Company
- Technology
- Sizes
- Thicknesses
- Surfaces
- Porcelain stoneware
- Ecologycare
- Certifications
- Quality and Safety
- Ceramic of Italy
- Fincibec Group
- Campus
- Engineering
- Pools & Wellness
- Facades
- Raised Flooring
- Technical Specifications

## Contents by collection

- |               |                 |
|---------------|-----------------|
| Archè         | Geobrick        |
| Ashley        | Graphis         |
| Azimuth       | On Stage        |
| Blade         | Pietra Castello |
| Charisma      | Pietre Naturali |
| Dicta         | Tradition       |
| Dolomite      | Transalp        |
| <b>Esprit</b> | Woodtime        |
| Evolution     | Yukon           |
| Gamut         | Major           |

## Contents by effect

- WOOD - Legno
- MARBLE - Marmo
- STONE - Pietra
- CONCRETE - Cemento

## Color Index

Color Index Major 20mm



## Energy



SUPERFICIE NATURALE / BORDO RETTIFICATO		A+B R10	
▲ 120x120 - 47"x47"	9	125794	163
60x120 - 24"x47"	9	128169	143

\* cm 120x260  
after after out of stock  
fino ad esaurimento scorte  
jusqu'à épuisement des stocks  
hasta agotar el stock  
solange der Vorrat reicht

▲ cm 120x278/120x260 pallet surcharge 140 € - stand containing 295 €  
cm 120x278/120x260 addebito cassa 140 € - cavalla 295 €  
cm 120x278/120x260 surtaxe caisse 140 € - chevalet 295 €  
cm 120x278/120x260 Aufpreis Kiste 140 € - Ständer 295 €  
cm 120x278/120x260 recargo caja 140 € - soporte 295 €

▲ cm 120x120 split pallet surcharge 40 € each - lightened stand containing 95 €  
cm 120x120 addebito frazione di paletta 40 € - cavalla alleggerita 95 €  
cm 120x120 surtaxe contremarque 40 € - chevalet allégé 95 €  
cm 120x120 Aufpreis Teilpalette 40 € - leichter Ständer 95 €  
cm 120x120 recargo fracción de paleta 40 € - soporte ligero 95 €



SUPERFICIE NATURALE / BORDO RETTIFICATO		A+B R10	
*▲ 120x260 - 47"x102"	7	130187	203
▲ 120x278 - 47"x109"	7	138443	203

## Special pieces - Pezzi speciali - Pièces spéciales - Formstücke - Piezas especiales

<b>BATTISCOPA 5,4x60 - 2"x24"</b>	<b>GRADINO 30x60 - 12"x24"</b>	<b>GRADONE COSTA RETTA 120x33 - 47"x13"</b>	<b>GRADONE ANGOLARE COSTA RETTA DX/SX 120x33 - 47"x13"</b>
NATURALE RETT. ● 10	NATURALE RETT. ● 55	NATURALE RETT. ● 333	NATURALE RETT. ● 345
	Minimum order 5 pieces / Ordine minimo 5 pz / Commande minimum 5 pièces / Mindestbestellmenge 5 Stück / Pedido minimo 5 piezas		

## Packaging - Imballi - Emballages - Verpackung - Embalajes

FLOOR TILES / PAVIMENTI / PAVIMENTS / GRUNDFLIESEN / AZULEJOS												
	sizes formati formats Formate formatos	120x278 47"x109,5"	120x260 47"x102"	120x120 47"x47"	60x120 24"x47"	80x80 31,5"x31,5"	60x60 24"x24"	30x60 12"x24"	39x20 15"x8" mosaico	32x30 13"x12" mosaico	30x30 4,7x4,7 12"x12"1,8"x1,8" mosaico	29x29 11"x11" mosaico
	boxes colli boîtes Kartons cajas	pc. CASSA 20	CASSA 20	2	2	2	3	6	5	5	11 fogli	5
	m <sup>2</sup>	66,7	62,4	2,88	1,44	1,28	1,08	1,08	0,39	0,48	1	0,42
	kg	1130	1060	58,0	31,0	26,2	22,5	22,5	7,8	9,6	20,3	7,5
	pallets pallet Paletts paletas	colli CAVALLA 36	CAVALLA 36	20	35	40	40	48				
	m <sup>2</sup>	120,2	112,3	57,6	50,4	51,2	43,2	51,8				
	kg	2230	1908	1160	1085	1048	900	1080				

SPECIAL PIECES / PEZZI SPECIALI / PIÈCES SPÉCIALES / FORMSTÜCKE / PIEZAS ESPECIALES					
	sizes formati formats Formate formatos	5,4x60 2,1"x24" battiscopa	30x60 12"x24" gradino	33x120 13"x47" gradone costa retta	33x120 13"x47" gradone angolare costa retta
	boxes colli boîtes Kartons cajas	pc. 14	1	1	1
	ml	8,4	0,6	1,2	1,2
	kg	11,0	3,5	11,2	11,7

## Slip - Scivolosità - Glissance - Rutschwert - Adherencia

	Standard Norma Standard   Norm   Norme   Norme	Natural Surface Superficie Natural   Surface Naturelle Natur Oberflächen   Superficie Natural
	B.C.R.A. (D.M.I. n. 236 μ>0,4)	> 0,40
	ANSI A 326.3 (DCOF WET >0,42)	> 0,42
	DIN EN 16165 ANNEX B	R10
	DIN EN 16165 ANNEX A	A+B
	BS EN 16165 ANNEX C	A+B MOSAICO 4,7x4,7 ≥ 36 Dry / ≥ 36 Wet
	AS 4586	Class P3

# Index

- The Company
- Technology
- Sizes
- Thicknesses
- Surfaces
- Porcelain stoneware
- Ecologycare
- Certifications
- Quality and Safety
- Ceramic of Italy
- Fincibec Group
- Campus
- Engineering
- Pools & Wellness
- Facades
- Raised Flooring
- Technical Specifications

## Contents by collection

- Archè
- Ashley
- Azimuth
- Blade
- Charisma
- Dicta
- Dolomite
- Esprit
- Evolution
- Gamut
- Geobrick
- Graphis
- On Stage
- Pietra Castello
- Pietre Naturali
- Tradition
- Transalp
- Woodtime
- Yukon
- Major

## Contents by effect

- WOOD - Legno
- MARBLE - Marmo
- STONE - Pietra
- CONCRETE - Cemento

## Color Index

Color Index Major 20mm

# Blade

Fine porcelain stoneware - Gres fine porcellanato  
Grès cérame fin - Feinsteinzeug - Gres fine porcelánico

download  
catalogue



Colours - Colori  
Couleurs - Farben - Colores

Pure

Vibe

Muse

Sword

Coal

**V2** Light variation - Lieve variazione  
Variation légère  
Gerinde Farbunterschied  
Variación escasa

Sizes - Formati  
Formats - Formaten - Formatos

120x278 cm  
(\*120x260 cm)  
120x120 cm  
60x120 cm  
30x120 cm  
80x80 cm  
60x60 cm  
30x60 cm

Thicknesses - Spessori  
Épaisseurs - Dicken - Espesores

7 mm  
9 mm

\* cm 120x260  
after after out of stock  
fino ad esaurimento scorte  
jusqu'à épuisement des stocks  
hasta agotar el stock  
solange der Vorrat reicht

Surfaces - Superfici  
Surfaces - Oberflächen - Superficies

Natural - Naturale  
Naturelle - Natur - Natural

Grip

Edges - Bordi  
Bordes - Kanten - Bordes

Rectified - Rettificato  
Rectifié - Rektifiziert - Rectificado

ISO 13006 Bla - EN 14411/G  
Fully-resistant flooring  
Pavimenti a resistenza totale  
Sols à résistance totale - Absolut widerständige  
Fußböden - Pavimentos de resistencia total



**c4** Floor tiles recommended for medium traffic areas.  
Piastrille da pavimento consigliate per calpestio medio.  
Carreaux de sol recommandés pour un trafic piétonnier moyen.  
Bodenfliesen, empfohlen für mittlere Beanspruchung.  
Baldosas de suelo recomendadas para el tránsito medio.

**c5** Floor tiles recommended for heavy uses.  
Piastrille da pavimento consigliate per calpestio intenso.  
Carreaux de sol recommandés pour un trafic piétonnier intense.  
Bodenfliesen, empfohlen für intensive Beanspruchung.  
Baldosas de suelo recomendadas para tránsito intenso.

concrete effect - effetto cemento - effet concret - effekt beton - konkrete wirkung - efecto concreto

## Index

The Company  
Technology  
Sizes  
Thicknesses  
Surfaces  
Porcelain stoneware  
Ecologycare  
Certifications  
Quality and Safety  
Ceramic of Italy  
Fincibec Group  
Campus  
Engineering  
Pools & Wellness  
Facades  
Raised Flooring  
Technical Specifications

### Contents by collection

Archè	Geobrick
Ashley	Graphis
Azimuth	On Stage
<b>Blade</b>	Pietra Castello
Charisma	Pietre Naturali
Dicta	Tradition
Dolomite	Transalp
Esprit	Woodtime
Evolution	Yukon
Gamut	Major

### Contents by effect

WOOD - Legno  
MARBLE - Marmo  
STONE - Pietra  
CONCRETE - Cemento

### Color Index

Color Index Major 20mm

# Blade

Fine porcelain stoneware - Gres fine porcellanato  
Grès cérame fin - Feinsteinzeug - Gres fine porcelánico

concrete effect - effetto cemento - effet concret - konkrete wirkung - efecto concreto

## Pure



### SUPERFICIE NATURALE / BORDO RETTIFICATO R10

▲ 120x120 - 47"x47"	工	9	118475	■	127
60x120 - 24"x47"	工	9	119875	■	93
30x120 - 12"x47"	工	9	119900	■	103
80x80 - 31,5"x31,5"	工	9	119890	■	93
60x60 - 24"x24"	工	9	119880	■	69
30x60 - 12"x24"	工	9	119885	■	63

### SUPERFICIE GRIP / BORDO RETTIFICATO A+B+C R11

60x120 - 24"x47"	工	9	120149	■	93
------------------	---	---	--------	---	----

\* cm 120x260  
after after out of stock  
fino ad esaurimento scorte  
jusqu'à épuisement des stocks  
hasta agotar el stock  
solange der Vorrat reicht

▲ cm 120x278/120x260 pallet surcharge 140 € - stand containing 295 €  
cm 120x278/120x260 addebito cassa 140 € - cavalla 295 €  
cm 120x278/120x260 surtaxe caisse 140 € - chevalet 295 €  
cm 120x278/120x260 Aufpreis Kiste 140 € - Ständer 295 €  
cm 120x278/120x260 recargo caja 140 € - soporte 295 €

▲ cm 120x120 split pallet surcharge 40 € each - lightened stand containing 95 €  
cm 120x120 addebito frazione di paletta 40 € - cavalla alleggerita 95 €  
cm 120x120 surtaxe contremarque 40 € - chevalet allégé 95 €  
cm 120x120 Aufpreis Teilpalette 40 € - leichter Ständer 95 €  
cm 120x120 recargo fracción de paleta 40 € - soporte ligero 95 €



### SUPERFICIE NATURALE / BORDO RETTIFICATO

*▲ 120x260 - 47"x102"	工	7	119315	■	203
▲ 120x278 - 47"x109"	工	7	138439	■	203

## Vibe



### SUPERFICIE NATURALE / BORDO RETTIFICATO R10

▲ 120x120 - 47"x47"	工	9	118477	■	127
60x120 - 24"x47"	工	9	119876	■	93
30x120 - 12"x47"	工	9	119901	■	103
80x80 - 31,5"x31,5"	工	9	119891	■	93
60x60 - 24"x24"	工	9	119881	■	69
30x60 - 12"x24"	工	9	119886	■	63

### SUPERFICIE GRIP / BORDO RETTIFICATO A+B+C R11

60x120 - 24"x47"	工	9	120150	■	93
------------------	---	---	--------	---	----

## Muse



### SUPERFICIE NATURALE / BORDO RETTIFICATO R10

▲ 120x120 - 47"x47"	工	9	118478	■	127
60x120 - 24"x47"	工	9	119877	■	93
30x120 - 12"x47"	工	9	119902	■	103
80x80 - 31,5"x31,5"	工	9	119892	■	93
60x60 - 24"x24"	工	9	119882	■	69
30x60 - 12"x24"	工	9	119887	■	63

### SUPERFICIE GRIP / BORDO RETTIFICATO A+B+C R11

60x120 - 24"x47"	工	9	120151	■	93
------------------	---	---	--------	---	----

▲ cm 120x120 split pallet surcharge 40 € each - lightened stand containing 95 €  
cm 120x120 addebito frazione di paletta 40 € - cavalla alleggerita 95 €  
cm 120x120 surtaxe contremarque 40 € - chevalet allégé 95 €  
cm 120x120 Aufpreis Teilpalette 40 € - leichter Ständer 95 €  
cm 120x120 recargo fracción de paleta 40 € - soporte ligero 95 €

# Index

- The Company
- Technology
- Sizes
- Thicknesses
- Surfaces
- Porcelain stoneware
- Ecologycare
- Certifications
- Quality and Safety
- Ceramic of Italy
- Fincibec Group
- Campus
- Engineering
- Pools & Wellness
- Facades
- Raised Flooring
- Technical Specifications

## Contents by collection

- Archè
- Ashley
- Azimuth
- Blade
- Charisma
- Dicta
- Dolomite
- Esprit
- Evolution
- Gamut
- Geobrick
- Graphis
- On Stage
- Pietra Castello
- Pietre Naturali
- Tradition
- Transalp
- Woodtime
- Yukon
- Major

## Contents by effect

- WOOD - Legno
- MARBLE - Marmo
- STONE - Pietra
- CONCRETE - Cemento

## Color Index

Color Index Major 20mm

# Blade

Fine porcelain stoneware - Gres fine porcellanato  
Grès cérame fin - Feinsteinzeug - Gres fine porcelánico

concrete effect - effetto cemento - effet concret - konkrete wirkung - efecto concreto

## Sword

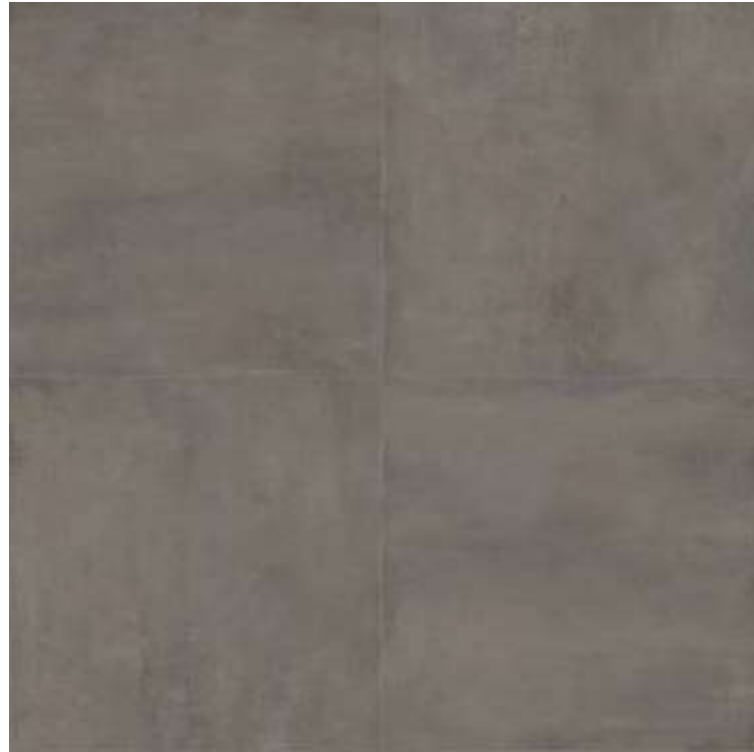

### SUPERFICIE NATURALE / BORDO RETTIFICATO R10

▲ 120x120 - 47"x47"	工	9	118474	■	127
60x120 - 24"x47"	工	9	119874	■	93
30x120 - 12"x47"	工	9	119899	■	103
80x80 - 31,5"x31,5"	工	9	119889	■	93
60x60 - 24"x24"	工	9	119879	■	69
30x60 - 12"x24"	工	9	119884	■	63

### SUPERFICIE GRIP / BORDO RETTIFICATO A+B+C R11

60x120 - 24"x47"	工	9	120148	■	93
------------------	---	---	--------	---	----

\* cm 120x260  
after after out of stock  
fino ad esaurimento scorte  
jusqu'à épuisement des stocks  
hasta agotar el stock  
solange der Vorrat reicht

▲ cm 120x278/120x260 pallet surcharge 140 € - stand containing 295 €  
cm 120x278/120x260 addebito cassa 140 € - cavalla 295 €  
cm 120x278/120x260 surtaxe caisse 140 € - chevalet 295 €  
cm 120x278/120x260 Aufpreis Kiste 140 € - Ständer 295 €  
cm 120x278/120x260 recargo caja 140 € - soporte 295 €

▲ cm 120x120 split pallet surcharge 40 € each - lightened stand containing 95 €  
cm 120x120 addebito frazione di paletta 40 € - cavalla alleggerita 95 €  
cm 120x120 surtaxe contremarque 40 € - chevalet allégé 95 €  
cm 120x120 Aufpreis Teilpalette 40 € - leichter Ständer 95 €  
cm 120x120 recargo fracción de paleta 40 € - soporte ligero 95 €



### SUPERFICIE NATURALE / BORDO RETTIFICATO

*▲ 120x260 - 47"x102"	工	7	119314	■	203
▲ 120x278 - 47"x109"	工	7	138440	■	203

## Coal



### SUPERFICIE NATURALE / BORDO RETTIFICATO R10

▲ 120x120 - 47"x47"	工	9	118473	■	127
60x120 - 24"x47"	工	9	119873	■	93
30x120 - 12"x47"	工	9	119898	■	103
80x80 - 31,5"x31,5"	工	9	119888	■	93
60x60 - 24"x24"	工	9	119878	■	69
30x60 - 12"x24"	工	9	119883	■	63

### SUPERFICIE GRIP / BORDO RETTIFICATO A+B+C R11

60x120 - 24"x47"	工	9	120147	■	93
------------------	---	---	--------	---	----

\* cm 120x260  
after after out of stock  
fino ad esaurimento scorte  
jusqu'à épuisement des stocks  
hasta agotar el stock  
solange der Vorrat reicht

▲ cm 120x278/120x260 pallet surcharge 140 € - stand containing 295 €  
cm 120x278/120x260 addebito cassa 140 € - cavalla 295 €  
cm 120x278/120x260 surtaxe caisse 140 € - chevalet 295 €  
cm 120x278/120x260 Aufpreis Kiste 140 € - Ständer 295 €  
cm 120x278/120x260 recargo caja 140 € - soporte 295 €

▲ cm 120x120 split pallet surcharge 40 € each - lightened stand containing 95 €  
cm 120x120 addebito frazione di paletta 40 € - cavalla alleggerita 95 €  
cm 120x120 surtaxe contremarque 40 € - chevalet allégé 95 €  
cm 120x120 Aufpreis Teilpalette 40 € - leichter Ständer 95 €  
cm 120x120 recargo fracción de paleta 40 € - soporte ligero 95 €



### SUPERFICIE NATURALE / BORDO RETTIFICATO

*▲ 120x260 - 47"x102"	工	7	119313	■	203
▲ 120x278 - 47"x109"	工	7	138438	■	203

# Index

- The Company
- Technology
- Sizes
- Thicknesses
- Surfaces
- Porcelain stoneware
- Ecologycare
- Certifications
- Quality and Safety
- Ceramic of Italy
- Fincibec Group
- Campus
- Engineering
- Pools & Wellness
- Facades
- Raised Flooring
- Technical Specifications

## Contents by collection

- |              |                 |
|--------------|-----------------|
| Archè        | Geobrick        |
| Ashley       | Graphis         |
| Azimuth      | On Stage        |
| <b>Blade</b> | Pietra Castello |
| Charisma     | Pietre Naturali |
| Dicta        | Tradition       |
| Dolomite     | Transalp        |
| Esprit       | Woodtime        |
| Evolution    | Yukon           |
| Gamut        | Major           |

## Contents by effect

- WOOD - Legno
- MARBLE - Marmo
- STONE - Pietra
- CONCRETE - Cemento

## Color Index

Color Index Major 20mm

# Blade

Fine porcelain stoneware - Gres fine porcellanato  
Grès cérame fin - Feinsteinzeug - Gres fine porcelánico

Decors - Decorì - Eléments décoratifs - Dekore - Decoraciones



## SUPERFICIE NATURALE /BORDO RETTIFICATO

\* BLADE MIX 60x60 - 24"x24" I 9 119310 ■ 103

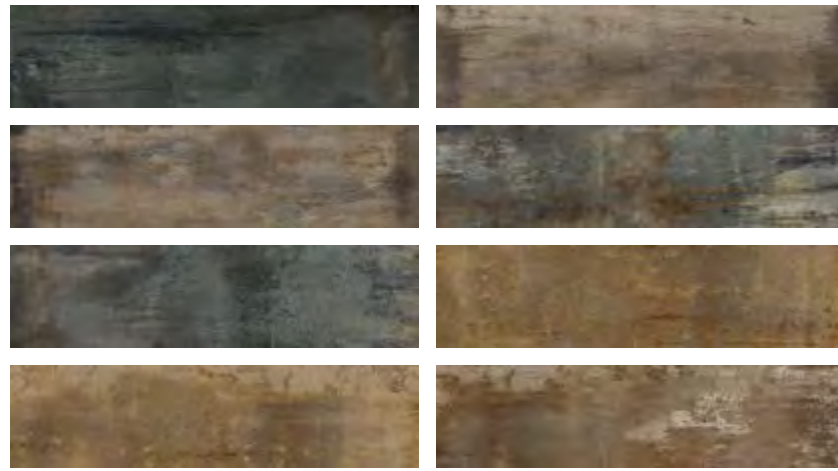

## SUPERFICIE NATURALE /BORDO RETTIFICATO

\* BLADE MIX 30x120 - 12"x47" I 9 120152 ■ 163

\*Decors version with multiple subjects, packaged randomly  
(Matchable with all colours)

Versione decoro con più soggetti, confezionati random  
(Abbinabili a tutti i colori)

Version décoration avec plusieurs motifs, emballés de manière  
aléatoire (pouvant être assortis à toutes les couleurs)

Dekorierter Ausführung mit mehreren Darstellungen, zufällige  
Zusammenstellung (kann mit allen Farben kombiniert werden)

Versión decoración con varios temas, empaquetados de modo  
aleatorio (se puede combinar con todos los colores)

concrete effect - effetto cemento - effet concret - konkrete wirkung - efecto concreto

Mosaics - Mosaici - Mosaïques - Mosaik - Mosaicos

SUPERFICIE NATURALE		A+B	
MOSAICO 4,7x4,7 - 1,8"x1,8" SU RETE 30x30 - 12"x12"			
PURE	I 9	120197	■ 253
VIBE	I 9	120198	■ 253
MUSE	I 9	120199	■ 253
SWARD	I 9	120196	■ 253
COAL	I 9	120195	■ 253

Special pieces - Pezzi speciali - Pièces spéciales - Formstücke - Piezas especiales

<b>GRADINO 30x60 - 12"x24"</b>	<b>GRADONE COSTA RETTA 120x33 - 47"x13"</b>	<b>GRADONE ANGOLARE COSTA RETTA DX/SX 120x33 - 47"x13"</b>	<b>BATTISCOPIA 5,4x60 - 2,1"x24"</b>
NATURALE RETT. ● 55	NATURALE RETT. ● 333	NATURALE RETT. ● 345	NATURALE RETT. ● 10
GRIP RETT. ● 55			
<b>Minimum order 5 pieces /</b> Ordine minimo 5 pz / Commande minimum 5 pièces / Mindestbestellmenge 5 Stück / Pedido mínimo 5 piezas			<b>ELEMENTO ELLE MONOLITICO 15x30x4 - 6"x12" x1,5"</b>
			GRIP RETT. ● 22

Packaging - Imballi - Emballages - Verpackung - Embalajes

### FLOOR TILES / PAVIMENTI / PAVIMENTS / GRUNDFLESIEN / AZULEJOS

sizes formati formats Formate formatos	120x278 47"x109,5"	120x260 47"x102"	120x120 47"x47"	60x120 24"x47"	30x120 12"x47"	80x80 31,5"x31,5"	60x60 24"x24"	30x60 12"x24"	30x120 12"x47" blade mix	60x60 24"x24" blade mix	30x30 4,7x4,7 12"x12" <sup>1,8"x1,8"</sup> mosaico
boxes colli boîtes Kartons cajas	pc. 20	CASSA 20	2	2	3	2	3	6	3	3	11 fogli
	m <sup>2</sup> 66,7	62,4	2,88	1,44	1,08	1,28	1,08	1,08	1,08	1,08	1
	kg 1130	1060	58,0	31,0	23,0	26,2	22,5	22,5	23,0	22,5	20,3
pallets pallet palette Paletts paletas	colli 36	CAVALLA 36	20	35	36	40	40	48			
	m <sup>2</sup> 120,2	112,3	57,6	50,4	38,9	51,2	43,2	51,8			
	kg 2230	1908	1160	1085	828	1048	900	1080			

### SPECIAL PIECES / PEZZI SPECIALI / PIÈCES SPÉCIALES / FORMSTÜCKE / PIEZAS ESPECIALES

sizes formati formats Formate formatos	5,4x60 2,1"x24" battiscopa	30x60 12"x24" gradino	33x120 13"x47" gradone costa retta	33x120 13"x47" gradone angolare costa retta	15x30x4 6"x12" x1,5" elemento elle monolitico
boxes colli boîtes Kartons cajas	pc. 14	1	1	1	6
	ml 8,4	0,6	1,2	1,2	1,8
	kg 11,0	3,5	11,2	11,7	8,1

Slip - Scivolosità - Glisance - Rutschwert - Adherencia

	Standard Norma Standard   Norm   Norme   Norme	Natural Surface Superficie Natural   Surface Naturelle Natur Oberflächen   Superficie Natural	Grip Surface Superficie Grip   Surface Grip Grip Oberflächen   Superficie Grip
	B.C.R.A. (D.M.I. n. 236 μ>0,4)	> 0,40	> 0,40
	ANSI A 326.3 (DCOF WET >0,42)	> 0,42	> 0,42
	DIN EN 16165 ANNEX B	R10	R11
	DIN EN 16165 ANNEX A	A+B MOSAICO 4,7x4,7	A+B+C
	BS EN 16165 ANNEX C	-	≥ 36 Dry / ≥ 36 Wet
	AS 4586	-	Class P4

# Index

The Company  
Technology  
Sizes  
Thicknesses  
Surfaces  
Porcelain stoneware  
Ecologycare  
Certifications  
Quality and Safety  
Ceramic of Italy  
Fincibec Group  
Campus  
Engineering  
Pools & Wellness  
Facades  
Raised Flooring  
Technical Specifications

## Contents by collection

Archè  
Ashley  
Azimuth  
**Blade**  
Charisma  
Dicta  
Dolomite  
Esprit  
Evolution  
Gamut  
Geobrick  
Graphis  
On Stage  
Pietra Castello  
Pietre Naturali  
Tradition  
Transalp  
Woodtime  
Yukon  
Major

## Contents by effect

WOOD - Legno  
MARBLE - Marmo  
STONE - Pietra  
CONCRETE - Cemento

## Color Index

Color Index Major 20mm

# Graphis

Fine porcelain stoneware - Gres fine porcellanato  
Grès cérame fin - Feinsteinzeug - Gres fine porcelánico

download  
catalogue



Colours - Colori  
Couleurs - Farben - Colores

Graphis Bianco

Graphis Beige

Graphis Grigio

Graphis Cenere

Sizes - Formati  
Formats - Formaten - Formatos

120x120 cm  
60x120 cm  
80x80 cm  
60x60 cm  
30x60 cm

Thicknesses - Spessori  
Epaisseurs - Dicken - Espesores

9 mm

Surfaces - Superfici  
Surfaces - Oberflächen - Superficies

Natural - Naturale  
Naturelle - Natur - Natural

Grip

Edges - Bordi  
Bordes - Kanten - Bordes

Rectified - Rettificato  
Rectifié - Rektifiziert - Rectificado

 **MAJOR**  
80x80 cm  
PAG. 190

 **Light variation** - Lieve variazione  
Variation légère  
Gerinde Farbunterschied  
Variación escasa

ISO 13006 Bla - EN 14411/G  
**Fully-resistant flooring**  
Pavimenti a resistenza totale  
Sols à résistance totale - Absolut widerständige  
Fußböden - Pavimentos de resistencia total



**c5** **Floor tiles recommended for heavy uses.**  
Piastrille da pavimento consigliate per calpestio intenso.  
Carreaux de sol recommandés pour un trafic piétonnier intense.  
Bodenfliesen, empfohlen für intensive Beanspruchung.  
Baldosas de suelo recomendadas para tránsito intenso.

concrete effect - effetto cemento - effet concret - effekt beton - konkrete wirkung - efecto concreto

## Index

- The Company
- Technology
- Sizes
- Thicknesses
- Surfaces
- Porcelain stoneware
- Ecologycare
- Certifications
- Quality and Safety
- Ceramic of Italy
- Fincibec Group
- Campus
- Engineering
- Pools & Wellness
- Facades
- Raised Flooring
- Technical Specifications

### > Contents by collection

- |           |                 |
|-----------|-----------------|
| Archè     | Geobrick        |
| Ashley    | <b>Graphis</b>  |
| Azimuth   | On Stage        |
| Blade     | Pietra Castello |
| Charisma  | Pietre Naturali |
| Dicta     | Tradition       |
| Dolomite  | Transalp        |
| Esprit    | Woodtime        |
| Evolution | Yukon           |
| Gamut     | Major           |

### > Contents by effect

- WOOD - Legno
- MARBLE - Marmo
- STONE - Pietra
- CONCRETE - Cemento

### > Color Index

Color Index Major 20mm

# Graphis

Fine porcelain stoneware - Gres fine porcellanato  
Grès cérame fin - Feinsteinzeug - Gres fine porcelánico

concrete effect - effetto cemento - effet concret - konkrete wirkung - efecto concreto

## Graphis Bianco

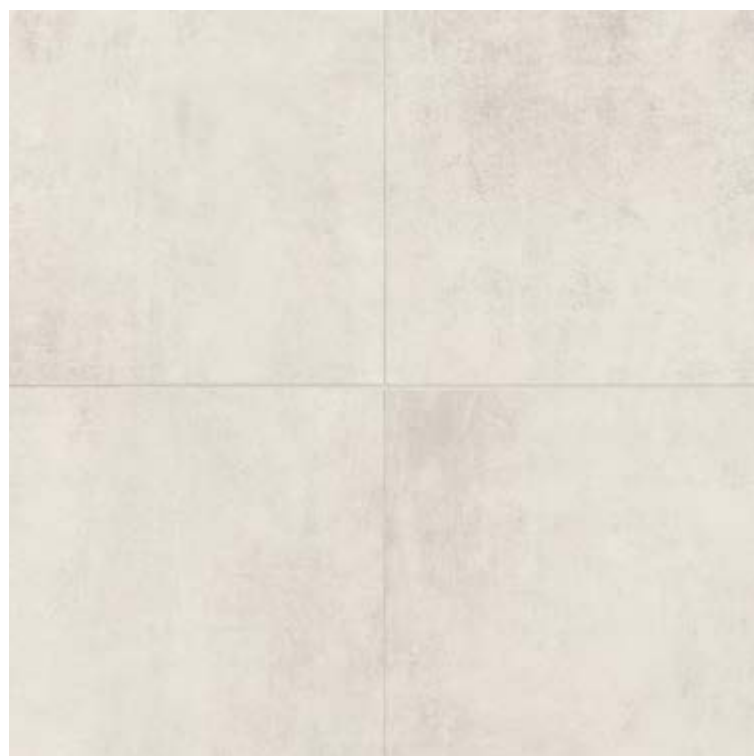

SUPERFICIE NATURALE / BORDO RETTIFICATO		R10	
▲ 120x120 - 47"x47"	9	112695	127
60x120 - 24"x47"	9	112866	93
80x80 - 31,5"x31,5"	9	112657	93
60x60 - 24"x24"	9	112690	69
30x60 - 12"x24"	9	112705	63

SUPERFICIE GRIP / BORDO RETTIFICATO		A+B+C R11	
60x60 - 24"x24"	9	113755	69

## Graphis Beige



SUPERFICIE NATURALE / BORDO RETTIFICATO		R10	
▲ 120x120 - 47"x47"	9	112697	127
60x120 - 24"x47"	9	112862	93
80x80 - 31,5"x31,5"	9	112658	93
60x60 - 24"x24"	9	112691	69
30x60 - 12"x24"	9	112707	63

SUPERFICIE GRIP / BORDO RETTIFICATO		A+B+C R11	
60x60 - 24"x24"	9	113753	69

## Graphis Grigio

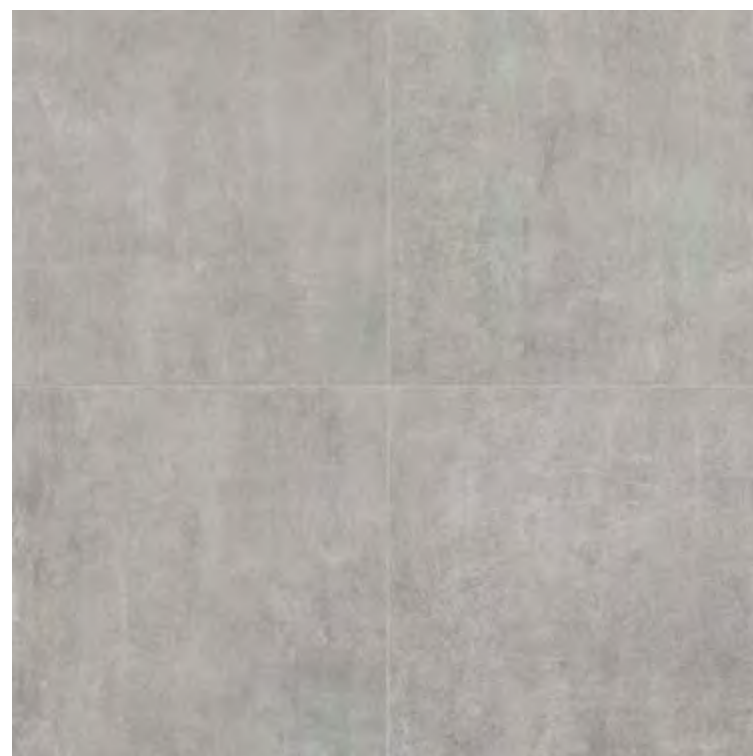

SUPERFICIE NATURALE / BORDO RETTIFICATO		R10	
▲ 120x120 - 47"x47"	9	112699	127
60x120 - 24"x47"	9	112858	93
80x80 - 31,5"x31,5"	9	112659	93
60x60 - 24"x24"	9	112692	69
30x60 - 12"x24"	9	112708	63

SUPERFICIE GRIP / BORDO RETTIFICATO		A+B+C R11	
60x60 - 24"x24"	9	113758	69

## Graphis Cenere

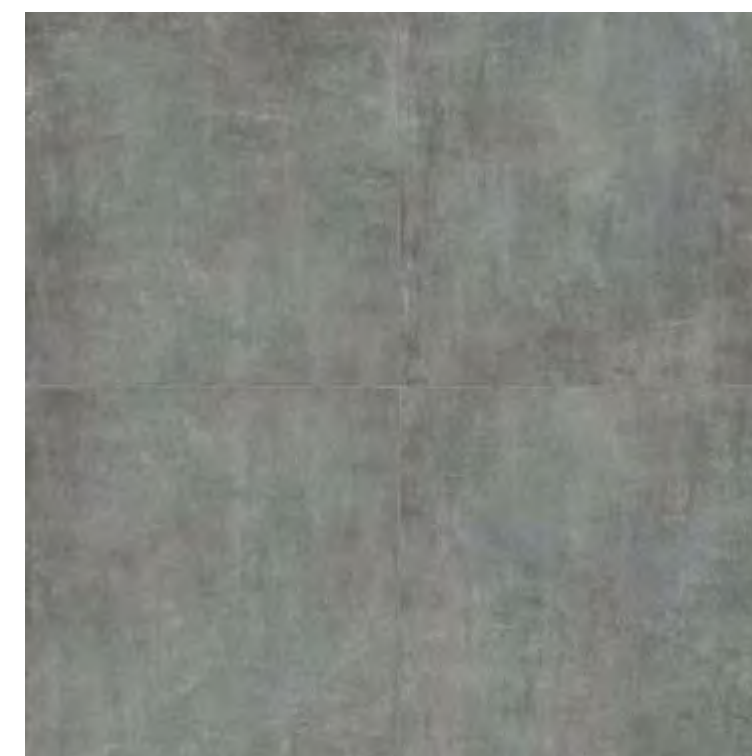

SUPERFICIE NATURALE / BORDO RETTIFICATO		R10	
▲ 120x120 - 47"x47"	9	112701	127
60x120 - 24"x47"	9	112854	93
80x80 - 31,5"x31,5"	9	112661	93
60x60 - 24"x24"	9	112693	69
30x60 - 12"x24"	9	112709	63

SUPERFICIE GRIP / BORDO RETTIFICATO		A+B+C R11	
60x60 - 24"x24"	9	113757	69

▲ cm 120x120 split pallet surcharge 40 € each - lightened stand containing 95 €  
cm 120x120 addebito frazione di paletta 40 € - cavalla alleggerita 95 €  
cm 120x120 surtaxe contremarque 40 € - chevalet allégé 95 €  
cm 120x120 Aufpreis Teilpalette 40 € - leichter Ständer 95 €  
cm 120x120 recargo fracción de paleta 40 € - soporte ligero 95 €

▲ cm 120x120 split pallet surcharge 40 € each - lightened stand containing 95 €  
cm 120x120 addebito frazione di paletta 40 € - cavalla alleggerita 95 €  
cm 120x120 surtaxe contremarque 40 € - chevalet allégé 95 €  
cm 120x120 Aufpreis Teilpalette 40 € - leichter Ständer 95 €  
cm 120x120 recargo fracción de paleta 40 € - soporte ligero 95 €

# Index

- The Company
- Technology
- Sizes
- Thicknesses
- Surfaces
- Porcelain stoneware
- Ecologycare
- Certifications
- Quality and Safety
- Ceramic of Italy
- Fincibec Group
- Campus
- Engineering
- Pools & Wellness
- Facades
- Raised Flooring
- Technical Specifications

## Contents by collection

- |           |                 |
|-----------|-----------------|
| Archè     | Geobrick        |
| Ashley    | <b>Graphis</b>  |
| Azimuth   | On Stage        |
| Blade     | Pietra Castello |
| Charisma  | Pietre Naturali |
| Dicta     | Tradition       |
| Dolomite  | Transalp        |
| Esprit    | Woodtime        |
| Evolution | Yukon           |
| Gamut     | Major           |

## Contents by effect

- WOOD - Legno
- MARBLE - Marmo
- STONE - Pietra
- CONCRETE - Cemento

## Color Index

Color Index Major 20mm

# Graphis

Fine porcelain stoneware - Gres fine porcellanato  
Grès cérame fin - Feinsteinzeug - Gres fine porcelánico

Decors - Decori - Eléments décoratifs - Dekore - Decoraciones



**SUPERFICIE NATURALE /BORDO RETTIFICATO**  
\* VISUAL 30x120 - 12"x47" | 9 | 113184 ■ 163

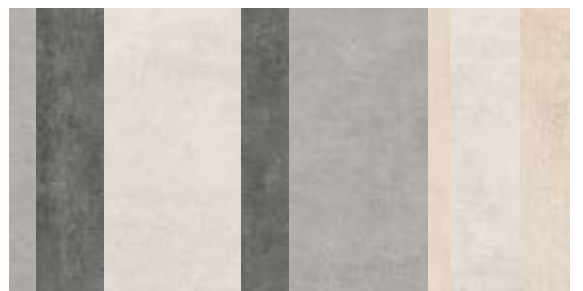

**SUPERFICIE NATURALE /BORDO RETTIFICATO**  
\* MOSAICO GRAPHIS MIX (SU RETE) 30x60 - 12"x24" | 9 | 113287 ■ 321



**SUPERFICIE NATURALE /BORDO RETTIFICATO**  
\* FORMELLA GRAPHIS MIX 20x20 - 8"x8" | 9 | 113183 ■ 209

\*Decors version with multiple subjects, packaged randomly (Matchable with all colours)

Versione decoro con più soggetti, confezionati random (Abbinabili a tutti i colori)

Version décoration avec plusieurs motifs, emballés de manière aléatoire (pouvant être assortis à toutes les couleurs)

Dekorierter Ausführung mit mehreren Darstellungen, zufällige Zusammenstellung (kann mit allen Farben kombiniert werden)

Versión decoración con varios temas, empaquetados de modo aleatorio (se puede combinar con todos los colores)

concrete effect - effetto cemento - effet concret - konkrete wirkung - efecto concreto

Mosaics - Mosaici - Mosaïques - Mosaik - Mosaicos

SUPERFICIE NATURALE		A+B	
MOSAICO 4,7x4,7 - 1,8"x1,8" SU RETE 30x30 - 12"x12"			
GRAPHIS BIANCO	9	113228	■ 253
GRAPHIS BEIGE	9	113227	■ 253
GRAPHIS GRIGIO	9	113226	■ 253
GRAPHIS CENERE	9	113225	■ 253

SUPERFICIE NATURALE		A+B+C	
MOSAICO 2,5x2,5 - 1"x1" SU FOGLIO 30x30 - 12"x12"			
GRAPHIS BIANCO	9	113257	■ 297
GRAPHIS BEIGE	9	113256	■ 297
GRAPHIS GRIGIO	9	113259	■ 297
GRAPHIS CENERE	9	113258	■ 297

Special pieces - Pezzi speciali - Pièces spéciales - Formstücke - Piezas especiales

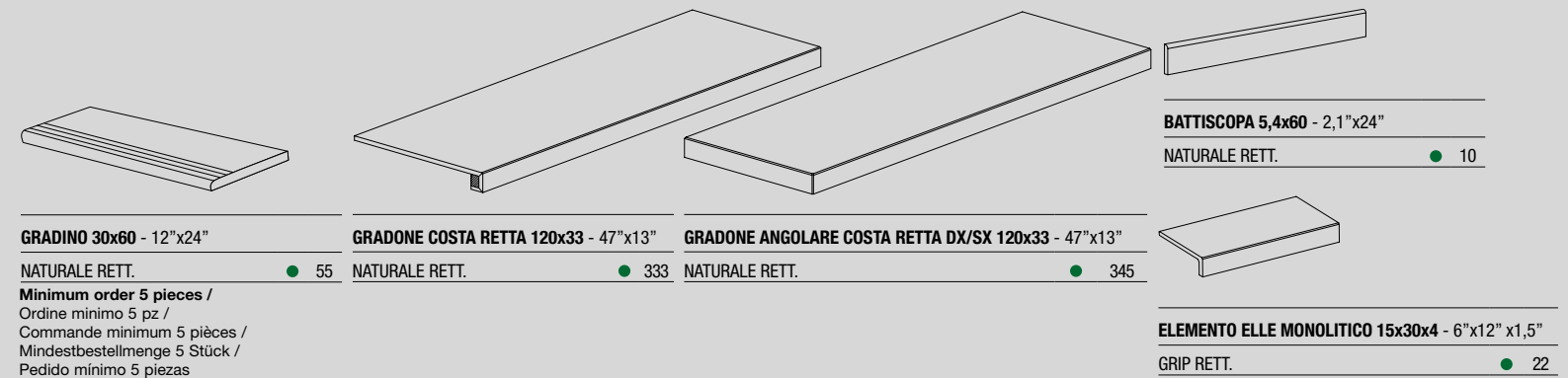

Packaging - Imballi - Emballages - Verpackung - Embalajes

FLOOR TILES / PAVIMENTI / PAVIMENTS / GRUNDFLIESEN / AZULEJOS											
	sizes formati formats Formate formatos	120x120 47"x47"	60x120 24"x47"	80x80 31,5"x31,5"	60x60 24"x24"	30x60 12"x24"	30x120 12"x47" visual	30x60 12"x24" mos. mix	20x20 8"x8" formella	30x30 4,7x4,7 12"x12" 1,8"x1,8" mosaico	30x30 2,5x2,5 12"x12" 1"x1" mosaico
boxes colli boîtes Kartons cajas	pc.	2	2	2	3	6	3	4	17	11 fogli	11 fogli
	m <sup>2</sup>	2,88	1,44	1,28	1,08	1,08	1,08	0,72	0,68	1	1
	kg	58,0	31,0	26,2	22,5	22,5	23,0	15,0	14,2	20,3	20,3
pallets pallet palette Paletts paletas	colli	20	35	40	40	48	36				
	m <sup>2</sup>	57,6	50,4	51,2	43,2	51,8	38,9				
	kg	1160	1085	1048	900	1080	828				

SPECIAL PIECES / PEZZI SPECIALI / PIÈCES SPÉCIALES / FORMSTÜCKE / PIEZAS ESPECIALES						
sizes formati formats Formate formatos	5,4x60 2,1"x24" battiscopa	30x60 12"x24" gradino	33x120 13"x47" gradone costa retta	33x120 13"x47" gradone angolare costa retta	15x30x4 6"x12" x1,5" elemento elle monolitico	
boxes colli boîtes Kartons cajas	pc.	14	1	1	1	6
	ml	8,4	0,6	1,2	1,2	1,8
	kg	11,0	3,5	11,2	11,7	8,1

Slip - Scivolosità - Glissance - Rutschwert - Adherencia

	Standard Norma Standard   Norm   Norme   Norme	Natural Surface Superficie Natural   Surface Naturelle Natur Oberflächen   Superficie Natural	Grip Surface Superficie Grip   Surface Grip Grip Oberflächen   Superficie Grip
	B.C.R.A. (D.M.I. n. 236 μ>0,4)	> 0,40	> 0,40
	ANSI A 326.3 (DCOF WET >0,42)	> 0,42	> 0,42
	DIN EN 16165 ANNEX B	R10	R11
	DIN EN 16165 ANNEX A	A+B MOSAICO 4,7x4,7 A+B+C MOSAICO 2,5x2,5	A+B+C
	BS EN 16165 ANNEX C	-	≥ 36 Dry / ≥ 36 Wet
	AS 4586	-	Class P4

## Index

The Company  
Technology  
Sizes  
Thicknesses  
Surfaces  
Porcelain stoneware  
Ecologycare  
Certifications  
Quality and Safety  
Ceramic of Italy  
Fincibec Group  
Campus  
Engineering  
Pools & Wellness  
Facades  
Raised Flooring  
Technical Specifications

## Contents by collection

Archè  
Ashley  
Azimuth  
Blade  
Charisma  
Dicta  
Dolomite  
Esprit  
Evolution  
Gamut  
Geobrick  
Graphis  
On Stage  
Pietra Castello  
Pietre Naturali  
Tradition  
Transalp  
Woodtime  
Yukon  
Major

## Contents by effect

WOOD - Legno  
MARBLE - Marmo  
STONE - Pietra  
CONCRETE - Cemento

## Color Index

Color Index Major 20mm





Fine porcelain stoneware - Gres fine porcellanato  
Grès cérame fin - Feinsteinzeug - Gres fine porcelánico

## MAJOR 20mm

*pag. 182* **Dicta**  
*pag. 183* **Archè**  
*pag. 184* **Dolomite**  
*pag. 186* **Crest**  
*pag. 187* **Geobrick**  
*pag. 188* **Tradition**  
*pag. 189* **Pietre Naturali**  
*pag. 190* **Graphis**

# Index

The Company  
Technology  
Sizes  
Thicknesses  
Surfaces  
Porcelain stoneware  
Ecologycare  
Certifications  
Quality and Safety  
Ceramic of Italy  
Fincibec Group  
Campus  
Engineering  
Pools & Wellness  
Facades  
Raised Flooring  
Technical Specifications

## > Contents by collection

Archè	Geobrick
Ashley	Graphis
Azimuth	On Stage
Blade	Pietra Castello
Charisma	Pietre Naturali
Dicta	Tradition
Dolomite	Transalp
Esprit	Woodtime
Evolution	Yukon
Gamut	<b>Major</b>

## > Contents by effect

WOOD - Legno  
MARBLE - Marmo  
STONE - Pietra  
CONCRETE - Cemento

## > Color Index

Color Index Major 20mm

The Company  
Technology  
Sizes  
Thicknesses  
Surfaces  
Porcelain stoneware  
Ecologycare  
Certifications  
Quality and Safety  
Ceramic of Italy  
Fincibec Group  
Campus  
Engineering  
Pools & Wellness  
Facades  
Raised Flooring  
Technical Specifications

## ➤ Contents by collection

Archè	Geobrick
Ashley	Graphis
Azimuth	On Stage
Blade	Pietra Castello
Charisma	Pietre Naturali
Dicta	Tradition
Dolomite	Transalp
Esprit	Woodtime
Evolution	Yukon
Gamut	<b>Major</b>

## ➤ Contents by effect

WOOD - Legno  
MARBLE - Marmo  
STONE - Pietra  
CONCRETE - Cemento

## ➤ Color Index

Color Index Major 20mm

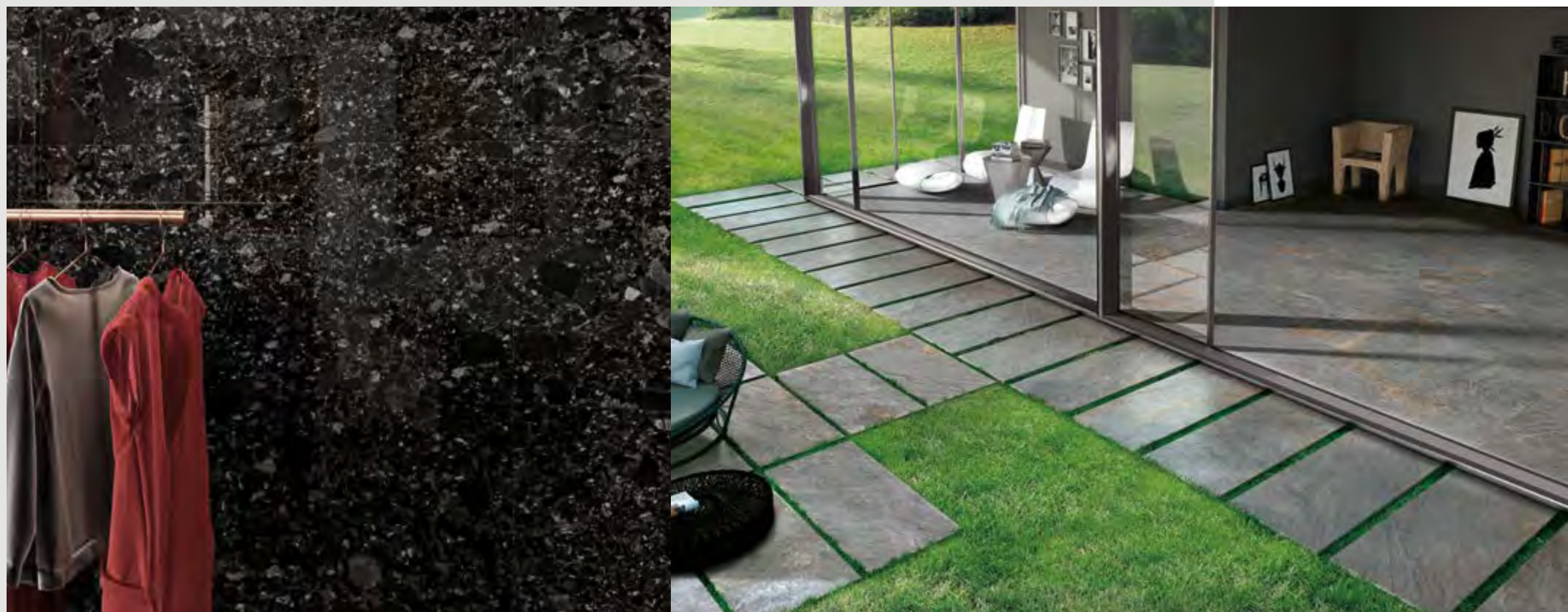

### Epaisseur 20 mm

La polyvalence et la résistance combinées à la haute performance antidérapante R11 A+B+C permettent d'utiliser le grès cérame Fincibec de 20 mm d'épaisseur pour les allées de jardins ou de plages, terrasses et balcons, voies de garage, bords de piscines et espaces bien-être. Il existe de nombreuses solutions de pose, de la pose à sec sur gravier, sable et herbe jusqu'à la chape traditionnelle et élevée sur supports. Fincibec Engineering est disponible pour le support technique et l'étude de solutions sur mesure pour répondre aux besoins du concepteur et du client.

### Dicken 20 mm

Vielseitigkeit und Widerstandsfähigkeit gepaart mit hoher Rutschhemmung der Klasse R11 A+B+C gestatten den Einsatz von Fincibec-Feinsteinzeug der Stärke 20 mm für Garten- und Strandwege, Terrassen und Balkone, Fahrwege, Swimmingpoolumrandungen und Wellnessbereiche. Vielseitige Verlegungslösungen, von der Trockenverlegung auf Kies, Sand und Rasen bis hin zur traditionellen Verlegung auf Estrich oder auf Doppelböden. Fincibec Engineering steht für technische Unterstützung und die Suche nach maßgeschneiderten Lösungen zur Verfügung, um jeden Kunden- und Planungsanspruch zu erfüllen.

### Espesor 20 mm

La versatilidad y resistencia combinadas con el alto rendimiento antideslizante R11 A + B + C permiten el uso de grés porcelánico Fincibec de 20 mm de espesor para pasillos dentro de jardines o playas, terrazas y balcones, entradas de vehículos, bordes de piscinas y áreas de wellness. Las soluciones de colocación son muchas, desde la colocación en seco sobre grava, arena y hierba hasta el tradicional pavimento y el pavimento elevado sobre soportes. Fincibec Engineering está disponible para soporte técnico y para el estudio de soluciones personalizadas para satisfacer las necesidades del diseñador y el cliente.

## 20 mm Thickness

Versatility and strength combined with high-performance anti-slip R11 A+B+C allow you to use Fincibec porcelain stoneware with a 20 mm width for walkways in gardens or on beaches, terraces and balconies, driveways, poolside and wellness areas. You have manifold of laying solutions from dry on gravel, sand and grass to traditional laying on screed and on raised supports. Fincibec Engineering is at your service for technical assistance and working out made-to-measure options to meet planner or customer needs.

–

## Spessore 20 mm

La versatilità e la resistenza abbinate alle elevate performance antiscivolo R11 A+B+C permettono di impiegare il grés porcellanato Fincibec in spessore 20 mm per camminamenti all'interno di giardini o su spiagge, terrazze e balconi, percorsi carrabili, bordi piscina e zone wellness. Le soluzioni di posa sono molteplici, da quella a secco su ghiaia, sabbia ed erba fino a quella su massetto tradizionale e sopraelevata su supporti. Fincibec Engineering è disponibile per il supporto tecnico e per lo studio di soluzioni su misura per soddisfare le esigenze del progettista e del cliente.

# Major 20mm

organizer 2024

## BENEFITS - PLUS - LES PLUS - DIE VORZÜGE - PLUS



### HIGH RESISTANCE TO BREAKING LOADS AND STRESS

ALTA RESISTENZA AI CARICHI DI ROTTURA E ALLE SOLLECITAZIONI

GRANDE RÉSIDENCE AUX CHARGES DE RUPTURE ET AUX PRESSIONS

HOHE BESTÄNDIGKEIT GEGEN BRUCHLAST UND ALLGEMEINE BEANSPRUCHUNGEN

ALTA RESISTENCIA A CARGAS DE ROTURA Y TENSIONES



### HIGH NON-SLIP PERFORMANCE: R11 A+B+C

ALTE PRESTAZIONI ANTISDRUCCIOLO: R11 A+B+C

PRESTATIONS ANTIDÉRAPANTES ÉLEVÉES: R11 A+B+C

HOHE RUTSCHFESTIGKEIT: R11 A+B+C

ALTO RENDIMIENTO ANTIDESLIZANTE: R11 A + B + C



### EASY TO CLEAN

FACILITÀ DI PULIZIA

FACILITÉ DE NETTOYAGE

EINFACH ZU REINIGEN

FACILIDAD DE LIMPIEZA



### DRY INSTALLATION ON GRAVEL

POSA A SECCO SU GHIAIA

A SEC SUR GRAVIER

TROCKEN AUF KIES

COLOCACIÓN EN SECO SOBRE GRAVA



### DRY INSTALLATION ON SAND

POSA A SECCO SU SABBIA

A SEC SUR SABLE

TROCKEN AUF SAND

COLOCACIÓN EN SECO SOBRE ARENA

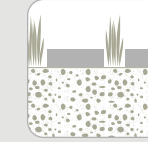

### DRY INSTALLATION ON GRASS

POSA A SECCO SU ERBA

A SEC SUR HERBE

TROCKEN AUF GRAS

COLOCACIÓN EN SECO SOBRE HIERBA



### TRADITIONAL INSTALLATION ON SCREEDS

POSA A SECCO TRADIZIONALE SU MASSETTO

TRADITIONNELLE SUR CHAPE

AUF HERKÖMMLICHE WEISE AUF ESTRICH

COLOCACIÓN EN SECO TRADICIONAL SOBRE MORTERO

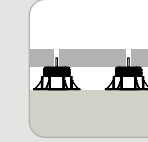

### RAISED INSTALLATION ON SUPPORTS

POSA SOPRAELEVATA SU SUPPORTI

SURÉLEVÉE SUR SUPPORTS

ALS DOPPELBODEN AUF TRÄGERN

COLOCACIÓN ELEVADA SOBRE SOPORTES



### HIGH RESISTANCE TO FROST AND FIRE

ALTA RESISTENZA AL GELO ED AL FUOCO

GRANDE RÉSIDENCE AU GEL ET AU FEU

HOHE BESTÄNDIGKEIT GEGEN FROST UND FEUER

ALTA RESISTENCIA A LAS HELADAS Y AL FUEGO



### RESISTANCE TO THE WEATHERING ELEMENTS AND THERMAL SHOCK

RESISTENZA AGLI AGENTI ATMOSFERICI E AGLI SBALZI TERMICI

RÉSISTANCE AUX AGENTS ATMOSPHÉRIQUES ET AUX ÉCARTS DE TEMPÉRATURE

BESTÄNDIGKEIT GEGEN WITTERUNGSEINFLÜSSE UND TEMPERATURSCHWANKUNGEN

RESISTENCIA A LOS AGENTES ATMOSFÉRICOS Y A LOS CAMBIOS DE TEMPERATURA

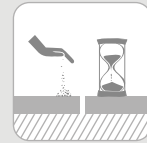

### RESISTANCE TO SALT AND INALTERABILITY OVER TIME

RESISTENZA AL SALE ED INALTERABILITÀ NEL TEMPO

RÉSISTANCE AU SEL ET INALTÉRABILITÉ AU FIL DU TEMPS

SALZBESTÄNDIGKEIT UND LANGE LEBENSDAUER

RESISTENCIA A LA SAL Y DURABILIDAD EN EL TIEMPO



### RESISTANT TO ACIDS

INATTACCABILE DAGLI ACIDI

INATTAQUABLE PAR LES ACIDES

SÄUREBESTÄNDIG

IMPERMEABLE A LOS ÁCIDOS

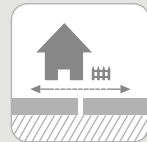

### PERFECT CONTINUITY BETWEEN INDOOR AND OUTDOOR AREAS

PERFETTA CONTINUITÀ INTERNO/ESTERNO

PARFAITE CONTINUITÉ INTÉRIEUR-EXTÉRIEUR

PERFEKTE KONTINUITÄT ZWISCHEN INNEN- UND AUSSENBEREICHEN

PERFECTA CONTINUIDAD INTERNA/EXTERNA



### REUSABLE

RIUTILIZZABILE

REUSABLE

RÉUTILISABLE

REUTILIZABLE



### EASY TO INSTALL, REMOVE AND REPOSITION \*

FACILITÀ DI POSA, RIMOZIONE E RIPOSIZIONAMENTO \*

FACILITÉ DE POSE, RETRAIT ET REPOSITIONNEMENT \*

EINFACHES VERLEGEN, ENTFERNEN UND ERNEUTES ANBRINGEN \*

FÁCIL DE COLOCACIÓN, RETIRO Y REPOSICIONAMIENTO \*

\* it does not require a specialized tile layer (in case of dry installation) neither the use of glues and grouts (in case of dry or raised installation)

\* non richiede l'intervento di un posatore specializzato (nel caso di posa a secco) e l'utilizzo di collanti e stucchi (nel caso di posa a secco e sopraelevata)

\* l'intervention d'un poseur spécialisé n'est pas nécessaire (dans le cas de la pose à sec) et ni l'usage de colles et de plâtres (dans le cas de la pose à sec et surélevée)

\* der eingriff eines fachverlegers (bei trockenverlegung) sowie der gebrauch von klebstoff und mörtel (bei trockenverlegung oder auf trägern) sind nicht erforderlich

\* no requiere la intervención de un instalador especializado (en el caso de colocación en seco) y el uso de colas y estucos (en el caso de colocación en seco y elevada)

## INSTALLATION SOLUTIONS - SOLUZIONI DI POSA

SOLUTIONS DE POSE - VERLEGUNGSMÖGLICHKEITEN - SOLUCIONES DE COLOCACIÓN

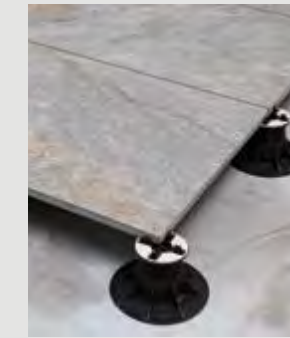
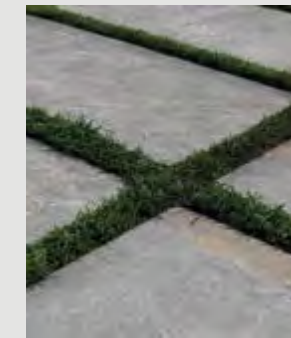

## INTENDED USES - DESTINAZIONI D'USO

UTILISATIONS PRÉVUES - VERWENDUNGSZWECKE - DESTINO DE USO

MAJOR's main features make it the ideal solution for any type of public and private outdoor flooring. MAJOR represents the best solution for:

- WALKWAYS IN GARDENS OR ON BEACHES
- TERRACES AND BALCONIES
- PATIOS, COURTYARDS, SWIMMING POOL EDGES, AND WELLNESS CENTRES
- DRIVE-OVER PATHWAYS

Les Plus de MAJOR en font le matériau idéal pour réaliser tout type de revêtement de sol dans des environnements extérieurs aussi bien publics que privés.

MAJOR représente la meilleure solution pour la réalisation de:

- CHEMINEMENTS DANS LES JARDINS OU SUR LES PLAGES
- TERRASSES ET BALCONS
- PATIOS, COURS, BORDS DE PISCINE ET ESPACES DE BIEN ÊTRE
- VOIES DE CIRCULATION POUR VÉHICULES

Die Pluspunkte von MAJOR machen dieses Material besonders geeignet für die Realisierung von Pflasterungen in öffentlichen und privaten Außenbereichen.

MAJOR bietet die beste Lösung für:

- FUSSWEGE IN GÄRTEN ODER AN STRÄNDEN
- TERRASSEN UND BALKONE
- PATIOS, INNENHÖFE, SCHWIMMBADRÄNDER UND WELLNESSBEREICHE
- BEFAHRBARE WEGE

I Plus di MAJOR rendono il materiale IDEALE PER realizzare ogni tipo di pavimentazione in ambienti esterni sia pubblici che privati. MAJOR rappresenta la migliore soluzione per la realizzazione di:

- CAMMINAMENTI ALL'INTERNO DI GIARDINI O SU SPIAGGE
- TERRAZZE E BALCONI
- PATII, CORTILI, BORDI PISCINA E ZONE WELLNESS
- PERCORSI CARRABILI

Los Plus de MAJOR hacen que el material sea ideal para hacer cualquier tipo de suelo en ambientes exteriores públicos y privados. MAYOR representa la mejor solución para la realización de:

- PASARELAS DENTRO DE JARDINES O EN PLAYAS
- TERRAZAS Y BALCONES
- PATIOS, CORTES, BORDES DE PISCINA Y ÁREAS DE WELLNESS
- ENTRADAS

# Index

The Company  
Technology  
Sizes  
Thicknesses  
Surfaces  
Porcelain stoneware  
Ecologycare  
Certifications  
Quality and Safety  
Ceramic of Italy  
Fincibec Group  
Campus  
Engineering  
Pools & Wellness  
Facades  
Raised Flooring  
Technical Specifications

## Contents by collection

Archè	Geobrick
Ashley	Graphis
Azimuth	On Stage
Blade	Pietra Castello
Charisma	Pietre Naturali
Dicta	Tradition
Dolomite	Transalp
Esprit	Woodtime
Evolution	Yukon
Gamut	Major

## Contents by effect

WOOD - Legno  
MARBLE - Marmo  
STONE - Pietra  
CONCRETE - Cemento

## Color Index

Color Index Major 20mm

# Major 20mm

Fine porcelain stoneware - Gres fine porcellanato  
Grès cérame fin - Feinsteinzeug - Gres fine porcelánico

Colours - Colori Couleurs - Farben - Colores

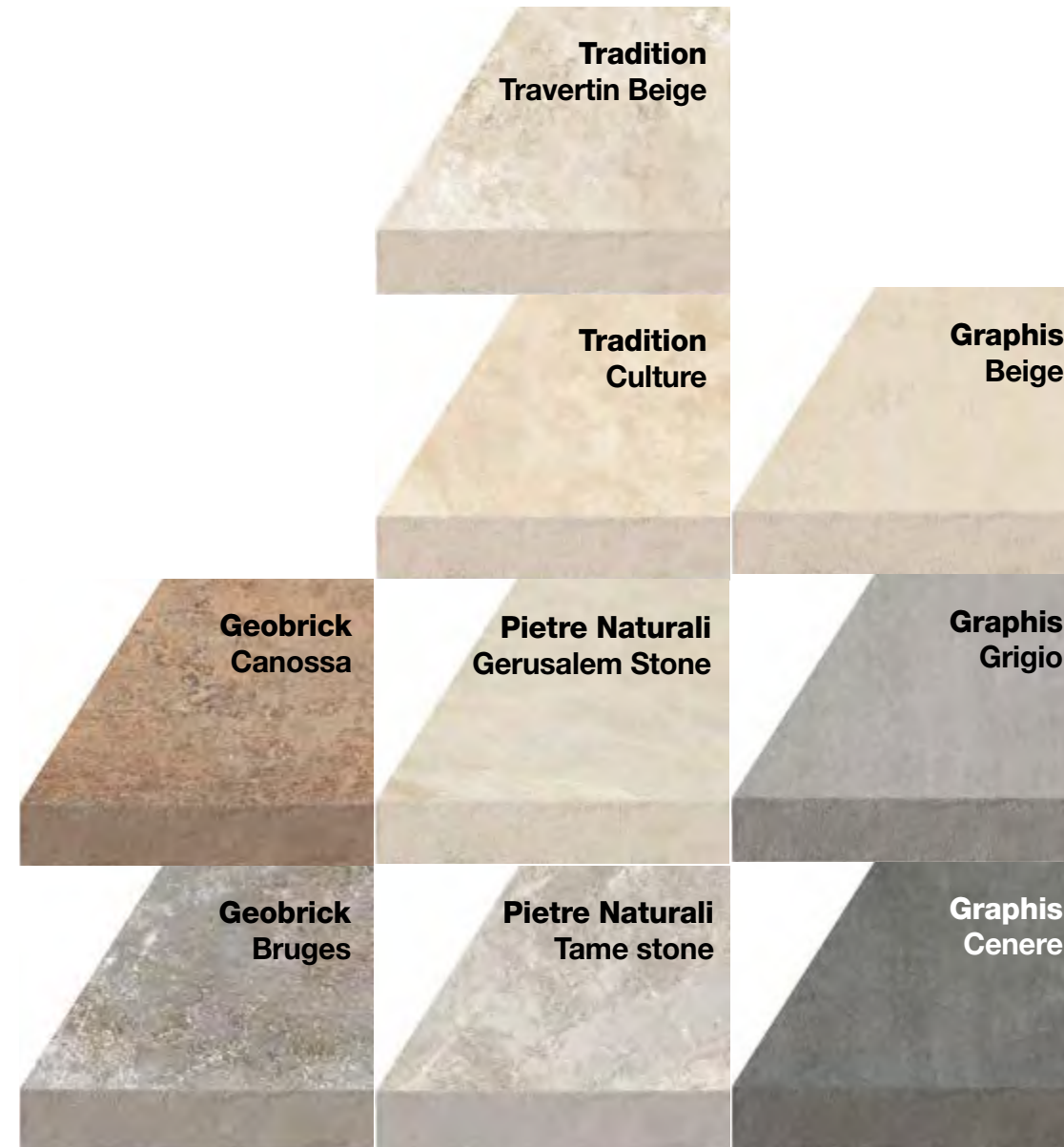
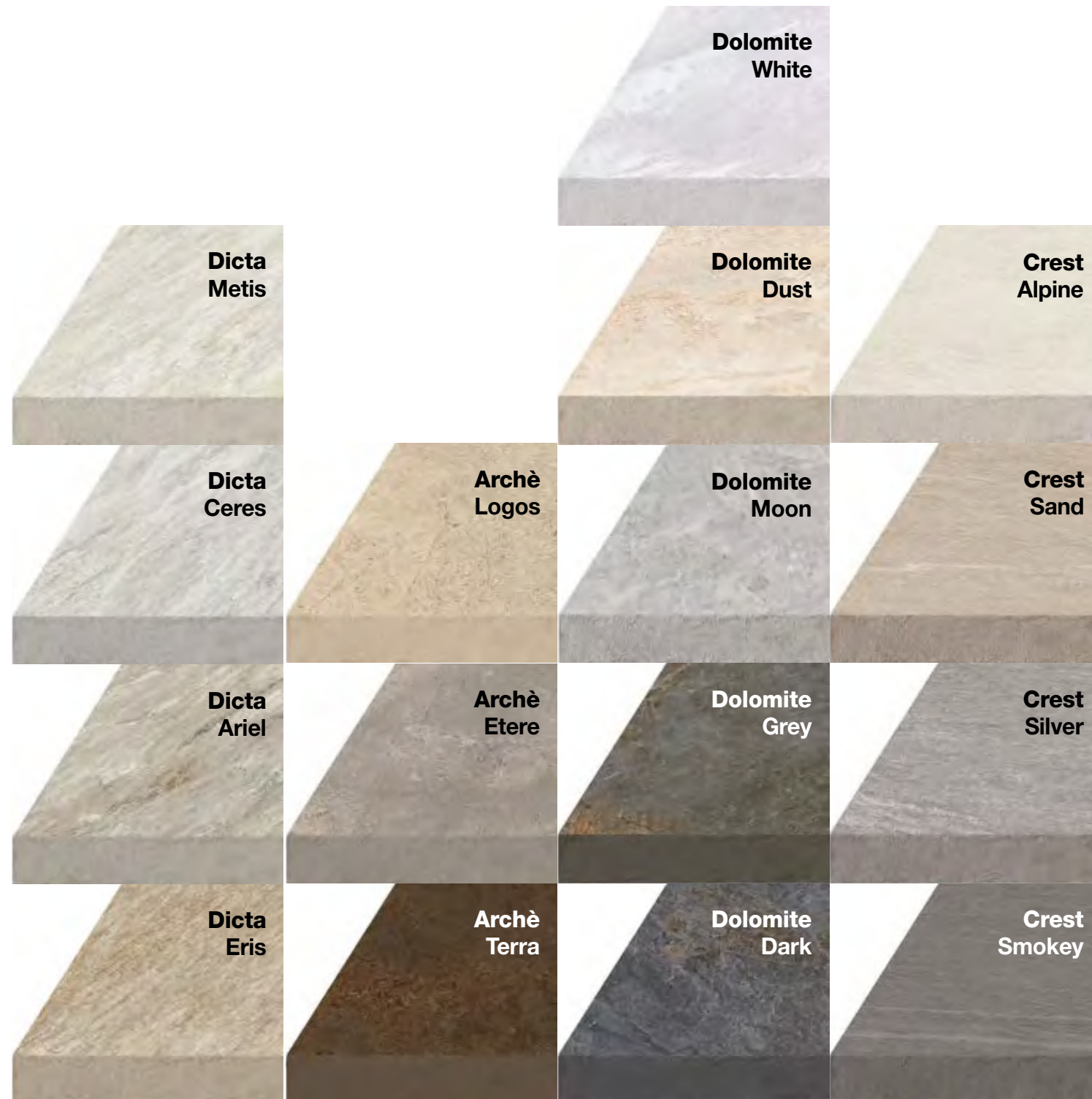

Sizes - Formati  
Formati - Formaten - Formatos

50x100 cm  
80x80 cm  
60x60 cm

Thicknesses - Spessori  
Epaisseurs - Dicken - Espesores

20 mm

Surfaces - Superfici  
Surfaces - Oberflächen - Superficies

Grip

Edges - Bordi  
Bordies - Kanten - Bordes

Natural - Naturale  
Naturel - Natur - Natural

Rectified - Rettificato  
Rectifié - Rektifiziert - Rectificado

## Index

- The Company
- Technology
- Sizes
- Thicknesses
- Surfaces
- Porcelain stoneware
- Ecologycare
- Certifications
- Quality and Safety
- Ceramic of Italy
- Fincibec Group
- Campus
- Engineering
- Pools & Wellness
- Facades
- Raised Flooring
- Technical Specifications

### > Contents by collection

- |           |                 |
|-----------|-----------------|
| Archè     | Geobrick        |
| Ashley    | Graphis         |
| Azimuth   | On Stage        |
| Blade     | Pietra Castello |
| Charisma  | Pietre Naturali |
| Dicta     | Tradition       |
| Dolomite  | Transalp        |
| Esprit    | Woodtime        |
| Evolution | Yukon           |
| Gamut     | <b>Major</b>    |

### > Contents by effect

- WOOD - Legno
- MARBLE - Marmo
- STONE - Pietra
- CONCRETE - Cemento

### > Color Index

Color Index Major 20mm

# Major 20mm Dicta

## Metis



<b>SUPERFICIE GRIP / BORDO NATURALE</b>	<b>A+B+C R11</b>
50x100 - 20"x40"	┌ 20   137879   ■ 133

<b>SUPERFICIE GRIP / BORDO RETTIFICATO</b>	<b>A+B+C R11</b>
50x100 - 20"x40"	┌ 20   137880   ■ 151

## Ariel



<b>SUPERFICIE GRIP / BORDO NATURALE</b>	<b>A+B+C R11</b>
50x100 - 20"x40"	┌ 20   136844   ■ 133

<b>SUPERFICIE GRIP / BORDO RETTIFICATO</b>	<b>A+B+C R11</b>
50x100 - 20"x40"	┌ 20   137065   ■ 151

Fine porcelain stoneware - Gres fine porcellanato  
Grès cérame fin - Feinsteinzeug - Gres fine porcelánico

## Ceres



<b>SUPERFICIE GRIP / BORDO NATURALE</b>	<b>A+B+C R11</b>
50x100 - 20"x40"	┌ 20   136847   ■ 133

<b>SUPERFICIE GRIP / BORDO RETTIFICATO</b>	<b>A+B+C R11</b>
50x100 - 20"x40"	┌ 20   137068   ■ 151

## Eris



<b>SUPERFICIE GRIP / BORDO NATURALE</b>	<b>A+B+C R11</b>
50x100 - 20"x40"	┌ 20   136846   ■ 133

<b>SUPERFICIE GRIP / BORDO RETTIFICATO</b>	<b>A+B+C R11</b>
50x100 - 20"x40"	┌ 20   137067   ■ 151

# Major 20mm Archè

## Logos



<b>SUPERFICIE GRIP / BORDO NATURALE</b>	<b>A+B+C R11</b>
50x100 - 20"x40"	┌ 20   133345   ■ 133

<b>SUPERFICIE GRIP / BORDO RETTIFICATO</b>	<b>A+B+C R11</b>
50x100 - 20"x40"	┌ 20   133348   ■ 151

## Terra

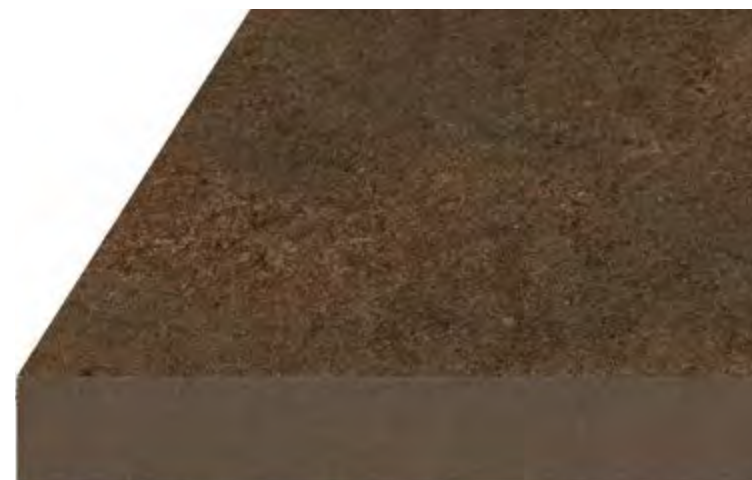

<b>SUPERFICIE GRIP / BORDO NATURALE</b>	<b>A+B+C R11</b>
50x100 - 20"x40"	┌ 20   133346   ■ 133

<b>SUPERFICIE GRIP / BORDO RETTIFICATO</b>	<b>A+B+C R11</b>
50x100 - 20"x40"	┌ 20   133349   ■ 151

Fine porcelain stoneware - Gres fine porcellanato  
Grès cérame fin - Feinsteinzeug - Gres fine porcelánico

## Etere



<b>SUPERFICIE GRIP / BORDO NATURALE</b>	<b>A+B+C R11</b>
50x100 - 20"x40"	┌ 20   133347   ■ 133

<b>SUPERFICIE GRIP / BORDO RETTIFICATO</b>	<b>A+B+C R11</b>
50x100 - 20"x40"	┌ 20   133350   ■ 151

## Major 20mm Dicta / Archè

ISO 13006 Bla - EN 14411/G  
Fully-resistant flooring  
Pavimenti a resistenza totale  
Sols à résistance totale - Absolut widerständige  
Fußböden - Pavimentos de resistencia total

<b>V2</b>	<b>Light variation - Lieve variazione</b> Variation légère Gerinde Farbunterschied Variación escasa
-----------	--

<b>C5</b>	<b>Floor tiles recommended for heavy uses.</b> Piastrelle da pavimento consigliate per calpestio intenso. Carreaux de sol recommandés pour un trafic piétonnier intense. Bodenfliesen, empfohlen für intensive Beanspruchung. Baldosas de suelo recomendadas para tránsito intenso.
-----------	---

**QB** UPEC:F+ En Cours  
50x100 Rectifié

# Index

- The Company
- Technology
- Sizes
- Thicknesses
- Surfaces
- Porcelain stoneware
- Ecologycare
- Certifications
- Quality and Safety
- Ceramic of Italy
- Fincibec Group
- Campus
- Engineering
- Pools & Wellness
- Facades
- Raised Flooring
- Technical Specifications

## Contents by collection

- Archè
- Ashley
- Azimuth
- Blade
- Charisma
- Dicta
- Dolomite
- Esprit
- Evolution
- Gamut
- Geobrick
- Graphis
- On Stage
- Pietra Castello
- Pietre Naturali
- Tradition
- Transalp
- Woodtime
- Yukon
- Major**

## Contents by effect

- WOOD - Legno
- MARBLE - Marmo
- STONE - Pietra
- CONCRETE - Cemento

## Color Index

Color Index Major 20mm

# Major 20mm Dolomite

## White



<b>SUPERFICIE GRIP / BORDO NATURALE</b>	<b>A+B+C R11</b>
50x100 - 20"x40"	20 93509 ■ 133

<b>SUPERFICIE GRIP / BORDO RETTIFICATO</b>	<b>A+B+C R11</b>
50x100 - 20"x40"	20 93718 ■ 151

Fine porcelain stoneware - Gres fine porcellanato  
Grès cérame fin - Feinsteinzeug - Gres fine porcelánico

## Dust



<b>SUPERFICIE GRIP / BORDO NATURALE</b>	<b>A+B+C R11</b>
50x100 - 20"x40"	20 93506 ■ 133

<b>SUPERFICIE GRIP / BORDO RETTIFICATO</b>	<b>A+B+C R11</b>
50x100 - 20"x40"	20 93714 ■ 151

## Dark

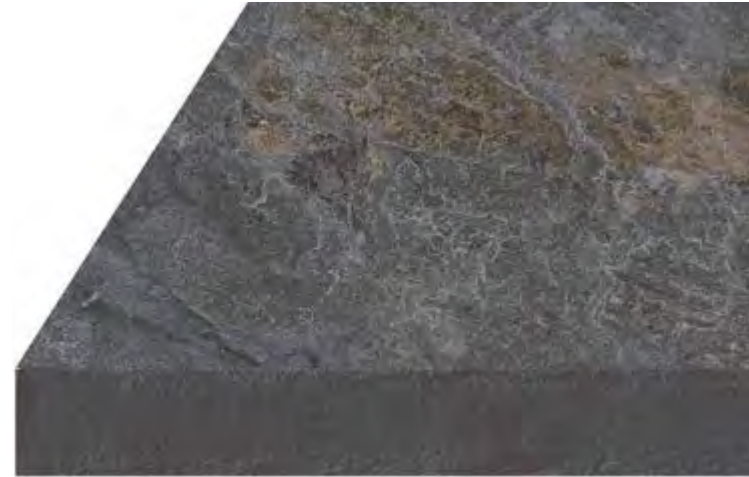

<b>SUPERFICIE GRIP / BORDO NATURALE</b>	<b>A+B+C R11</b>
50x100 - 20"x40"	20 93505 ■ 133

<b>SUPERFICIE GRIP / BORDO RETTIFICATO</b>	<b>A+B+C R11</b>
50x100 - 20"x40"	20 93713 ■ 151

Fine porcelain stoneware - Gres fine porcellanato  
Grès cérame fin - Feinsteinzeug - Gres fine porcelánico

## Moon



<b>SUPERFICIE GRIP / BORDO NATURALE</b>	<b>A+B+C R11</b>
50x100 - 20"x40"	20 93508 ■ 133

<b>SUPERFICIE GRIP / BORDO RETTIFICATO</b>	<b>A+B+C R11</b>
50x100 - 20"x40"	20 93716 ■ 151

## Grey

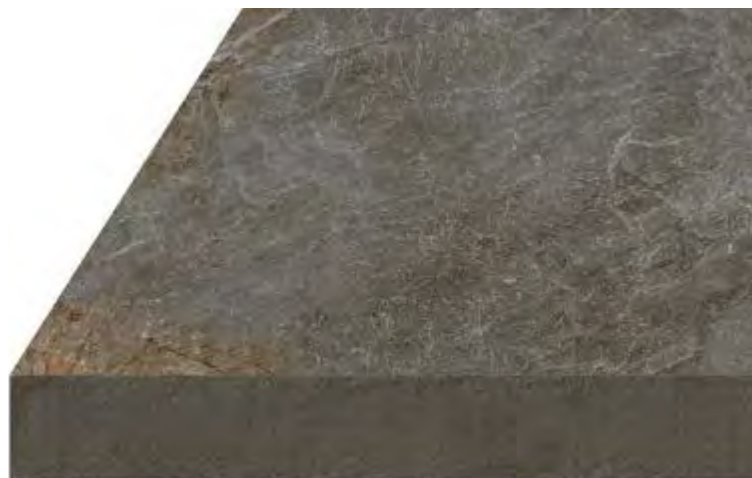

<b>SUPERFICIE GRIP / BORDO NATURALE</b>	<b>A+B+C R11</b>
50x100 - 20"x40"	20 93507 ■ 133

<b>SUPERFICIE GRIP / BORDO RETTIFICATO</b>	<b>A+B+C R11</b>
50x100 - 20"x40"	20 93715 ■ 151

ISO 13006 Bla - EN 14411/G  
Fully-resistant flooring  
Pavimenti a resistenza totale  
Sols à résistance totale - Absolut widerständige  
Fußböden - Pavimentos de resistencia total

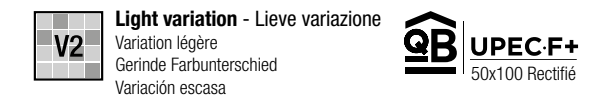

**c5** Floor tiles recommended for heavy uses.  
Piastrille da pavimento consigliate per calpestio intenso.  
Carreaux de sol recommandés pour un trafic piétonnier intense.  
Bodenfliesen, empfohlen für intensive Beanspruchung.  
Baldosas de suelo recomendadas para tránsito intenso.

# Index

- The Company
- Technology
- Sizes
- Thicknesses
- Surfaces
- Porcelain stoneware
- Ecologycare
- Certifications
- Quality and Safety
- Ceramic of Italy
- Fincibec Group
- Campus
- Engineering
- Pools & Wellness
- Facades
- Raised Flooring
- Technical Specifications

## Contents by collection

- Archè
- Ashley
- Azimuth
- Blade
- Charisma
- Dicta
- Dolomite
- Esprit
- Evolution
- Gamut
- Geobrick
- Graphis
- On Stage
- Pietra Castello
- Pietre Naturali
- Tradition
- Transalp
- Woodtime
- Yukon
- Major**

## Contents by effect

- WOOD - Legno
- MARBLE - Marmo
- STONE - Pietra
- CONCRETE - Cemento

## Color Index

Color Index Major 20mm

# Major 20mm Crest

## Alpine



<b>SUPERFICIE GRIP / BORDO NATURALE</b>	<b>A+B+C R11</b>
50x100 - 20"x40"	┌ 20 93510 ┐ ■ 133

<b>SUPERFICIE GRIP / BORDO RETTIFICATO</b>	<b>A+B+C R11</b>
50x100 - 20"x40"	┌ 20 93928 ┐ ■ 151

Fine porcelain stoneware - Gres fine porcellanato  
Grès cérame fin - Feinsteinzeug - Gres fine porcelánico

## Sand



<b>SUPERFICIE GRIP / BORDO NATURALE</b>	<b>A+B+C R11</b>
50x100 - 20"x40"	┌ 20 93511 ┐ ■ 133

<b>SUPERFICIE GRIP / BORDO RETTIFICATO</b>	<b>A+B+C R11</b>
50x100 - 20"x40"	┌ 20 93929 ┐ ■ 151

## Silver



<b>SUPERFICIE GRIP / BORDO NATURALE</b>	<b>A+B+C R11</b>
50x100 - 20"x40"	┌ 20 93512 ┐ ■ 133

<b>SUPERFICIE GRIP / BORDO RETTIFICATO</b>	<b>A+B+C R11</b>
50x100 - 20"x40"	┌ 20 93930 ┐ ■ 151

## Smokey

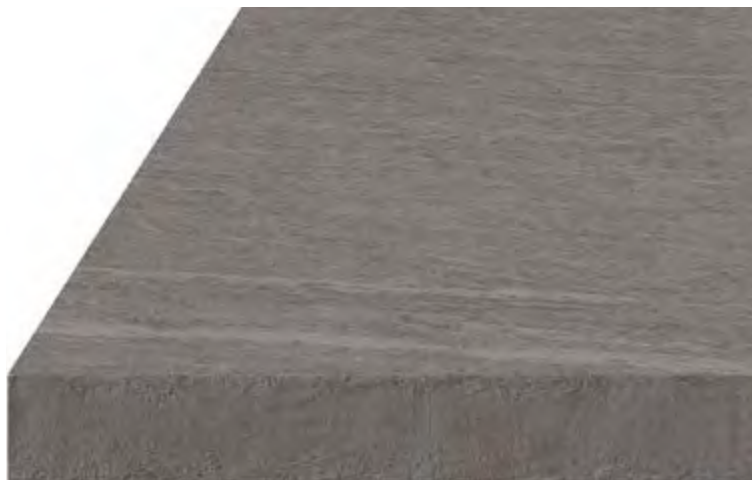

<b>SUPERFICIE GRIP / BORDO NATURALE</b>	<b>A+B+C R11</b>
50x100 - 20"x40"	┌ 20 93513 ┐ ■ 133

<b>SUPERFICIE GRIP / BORDO RETTIFICATO</b>	<b>A+B+C R11</b>
50x100 - 20"x40"	┌ 20 93931 ┐ ■ 151

# Major 20mm Geobrick

## Canossa



<b>SUPERFICIE GRIP / BORDO RETTIFICATO</b>	<b>A+B+C R11</b>
80x80 - 31,5"x31,5"	┌ 20 107665 ┐ ■ 157
60x60 - 24"x24"	┌ 20 107650 ┐ ■ 133

Fine porcelain stoneware - Gres fine porcellanato  
Grès cérame fin - Feinsteinzeug - Gres fine porcelánico

## Bruges



<b>SUPERFICIE GRIP / BORDO RETTIFICATO</b>	<b>A+B+C R11</b>
80x80 - 31,5"x31,5"	┌ 20 107666 ┐ ■ 157

## Major 20mm Crest

ISO 13006 Bla - EN 14411/G  
Fully-resistant flooring  
Pavimenti a resistenza totale  
Sols à résistance totale - Absolut widerständige  
Fußböden - Pavimentos de resistencia total

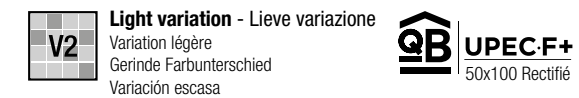

**c5** Floor tiles recommended for heavy uses.  
Piastrille da pavimento consigliate per calpestio intenso.  
Carreaux de sol recommandés pour un trafic piétonnier intense.  
Bodenfliesen, empfohlen für intensive Beanspruchung.  
Baldosas de suelo recomendadas para tránsito intenso.

## Major 20mm Geobrick

ISO 13006 Bla - EN 14411/G  
Fully-resistant flooring  
Pavimenti a resistenza totale  
Sols à résistance totale - Absolut widerständige  
Fußböden - Pavimentos de resistencia total

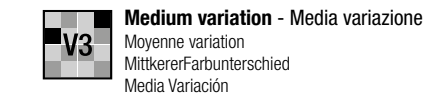

**c5** Floor tiles recommended for heavy uses.  
Piastrille da pavimento consigliate per calpestio intenso.  
Carreaux de sol recommandés pour un trafic piétonnier intense.  
Bodenfliesen, empfohlen für intensive Beanspruchung.  
Baldosas de suelo recomendadas para tránsito intenso.

# Index

- The Company
- Technology
- Sizes
- Thicknesses
- Surfaces
- Porcelain stoneware
- Ecologycare
- Certifications
- Quality and Safety
- Ceramic of Italy
- Fincibec Group
- Campus
- Engineering
- Pools & Wellness
- Facades
- Raised Flooring
- Technical Specifications

## Contents by collection

- Archè
- Ashley
- Azimuth
- Blade
- Charisma
- Dicta
- Dolomite
- Esprit
- Evolution
- Gamut
- Geobrick
- Graphis
- On Stage
- Pietra Castello
- Pietre Naturali
- Tradition
- Transalp
- Woodtime
- Yukon
- Major**

## Contents by effect

- WOOD - Legno
- MARBLE - Marmo
- STONE - Pietra
- CONCRETE - Cemento

## Color Index

Color Index Major 20mm

# Major 20mm Tradition

## Travertin Beige



SUPERFICIE GRIP / BORDO NATURALE		A+B+C R11	
50x100 - 20"x40"	┌ 20	┌ 124264	■ 133

SUPERFICIE GRIP / BORDO RETTIFICATO		A+B+C R11	
50x100 - 20"x40"	┌ 20	┌ 124266	■ 151

Fine porcelain stoneware - Gres fine porcellanato  
Grès cérame fin - Feinsteinzeug - Gres fine porcelánico

## Culture



SUPERFICIE GRIP / BORDO NATURALE		A+B+C R11	
50x100 - 20"x40"	┌ 20	┌ 124265	■ 133

SUPERFICIE GRIP / BORDO RETTIFICATO		A+B+C R11	
50x100 - 20"x40"	┌ 20	┌ 124267	■ 151

ISO 13006 Bla - EN 14411/G  
Fully-resistant flooring  
Pavimenti a resistenza totale  
Sols à résistance totale - Absolut widerständige  
Fußböden - Pavimentos de resistencia total



**c5** Floor tiles recommended for heavy uses.  
Piastrille da pavimento consigliate per calpestio intenso.  
Carreaux de sol recommandés pour un trafic piétonnier intense.  
Bodenfliesen, empfohlen für intensive Beanspruchung.  
Baldosas de suelo recomendadas para tránsito intenso.

# Major 20mm Pietre Naturali

## Gerusalem Stone



SUPERFICIE GRIP / BORDO NATURALE		A+B+C R11	
50x100 - 20"x40"	┌ 20	┌ 100576	■ 133

SUPERFICIE GRIP / BORDO RETTIFICATO		A+B+C R11	
50x100 - 20"x40"	┌ 20	┌ 100581	■ 151
80x80 - 31,5"x31,5"	┌ 20	┌ 107632	■ 157
60x60 - 24"x24"	┌ 20	┌ 107614	■ 133

Fine porcelain stoneware - Gres fine porcellanato  
Grès cérame fin - Feinsteinzeug - Gres fine porcelánico

## Tame Stone



SUPERFICIE GRIP / BORDO RETTIFICATO		A+B+C R11	
80x80 - 31,5"x31,5"	┌ 20	┌ 107633	■ 157
60x60 - 24"x24"	┌ 20	┌ 107615	■ 133

ISO 13006 Bla - EN 14411/G  
Fully-resistant flooring  
Pavimenti a resistenza totale  
Sols à résistance totale - Absolut widerständige  
Fußböden - Pavimentos de resistencia total

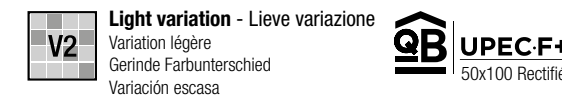

**c5** Floor tiles recommended for heavy uses.  
Piastrille da pavimento consigliate per calpestio intenso.  
Carreaux de sol recommandés pour un trafic piétonnier intense.  
Bodenfliesen, empfohlen für intensive Beanspruchung.  
Baldosas de suelo recomendadas para tránsito intenso.

# Index

- The Company
- Technology
- Sizes
- Thicknesses
- Surfaces
- Porcelain stoneware
- Ecologycare
- Certifications
- Quality and Safety
- Ceramic of Italy
- Fincibec Group
- Campus
- Engineering
- Pools & Wellness
- Facades
- Raised Flooring
- Technical Specifications

## Contents by collection

- Archè
- Ashley
- Azimuth
- Blade
- Charisma
- Dicta
- Dolomite
- Esprit
- Evolution
- Gamut
- Geobrick
- Graphis
- On Stage
- Pietra Castello
- Pietre Naturali
- Tradition
- Transalp
- Woodtime
- Yukon
- Major**

## Contents by effect

- WOOD - Legno
- MARBLE - Marmo
- STONE - Pietra
- CONCRETE - Cemento

## Color Index

Color Index Major 20mm



# Major 20mm Graphis

## Graphis Beige



**SUPERFICIE GRIP / BORDO RETTIFICATO** **A+B+C R11**  
80x80 - 31,5"x31,5"  20  113761  157

Fine porcelain stoneware - Gres fine porcellanato  
Grès cérame fin - Feinsteinzeug - Gres fine porcelánico

## Graphis Grigio



**SUPERFICIE GRIP / BORDO RETTIFICATO** **A+B+C R11**  
80x80 - 31,5"x31,5"  20  113760  157

## Graphis Cenere



**SUPERFICIE GRIP / BORDO RETTIFICATO** **A+B+C R11**  
80x80 - 31,5"x31,5"  20  113759  157

ISO 13006 Bla - EN 14411/G  
Fully-resistant flooring  
Pavimenti a resistenza totale  
Sols à résistance totale - Absolut widerständige  
Fußböden - Pavimentos de resistencia total

**V2** **Light variation - Lieve variazione**  
Variation légère  
Gerinde Farbunterschied  
Variación escasa

**C5** **Floor tiles recommended for heavy uses.**  
Piastrille da pavimento consigliate per calpestio intenso.  
Carreaux de sol recommandés pour un trafic piétonnier intense.  
Bodenfliesen, empfohlen für intensive Beanspruchung.  
Baldosas de suelo recomendadas para tránsito intenso.

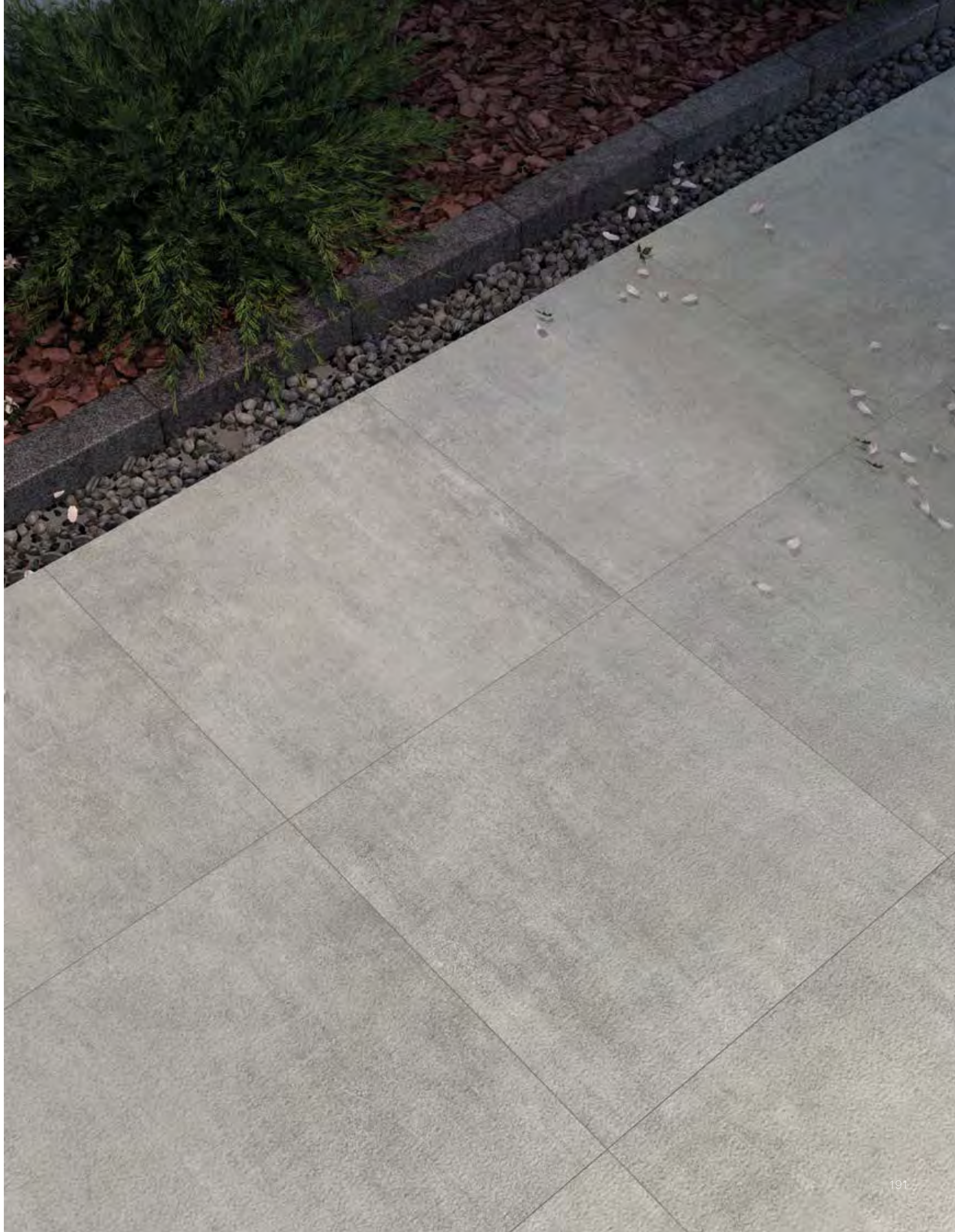

# Index

- The Company
- Technology
- Sizes
- Thicknesses
- Surfaces
- Porcelain stoneware
- Ecologycare
- Certifications
- Quality and Safety
- Ceramic of Italy
- Fincibec Group
- Campus
- Engineering
- Pools & Wellness
- Facades
- Raised Flooring
- Technical Specifications

## ➤ Contents by collection

- |           |                 |
|-----------|-----------------|
| Archè     | Geobrick        |
| Ashley    | Graphis         |
| Azimuth   | On Stage        |
| Blade     | Pietra Castello |
| Charisma  | Pietre Naturali |
| Dicta     | Tradition       |
| Dolomite  | Transalp        |
| Esprit    | Woodtime        |
| Evolution | Yukon           |
| Gamut     | <b>Major</b>    |

## ➤ Contents by effect

- WOOD - Legno
- MARBLE - Marmo
- STONE - Pietra
- CONCRETE - Cemento

## ➤ Color Index

Color Index Major 20mm

### Archè - Dicta - Tradition

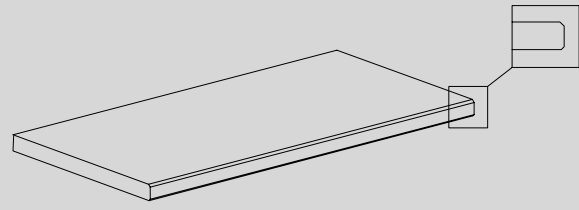

**BORDO COSTA 50x100 - 20"x40"**  
GRIP RETT. I 20 ● 297

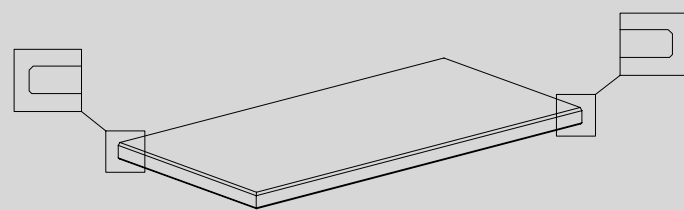

**BORDO COSTA DX/SX 50x100 - 20"x40"**  
GRIP RETT. I 20 ● 337

### Tradition

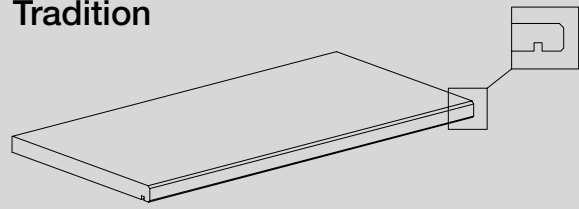

**BORDO COSTA CON GOCCIOLATOIO 50x100 - 20"x40"**  
GRIP RETT. I 20 ● 305

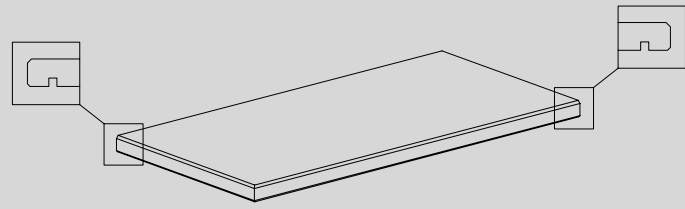

**ANGOLARE BORDO COSTA CON GOCCIOLATOIO DX/SX 50x100 - 20"x40"**  
GRIP RETT. I 20 ● 349

### Archè - Crest - Dicta - Dolomite - Pietre Naturali

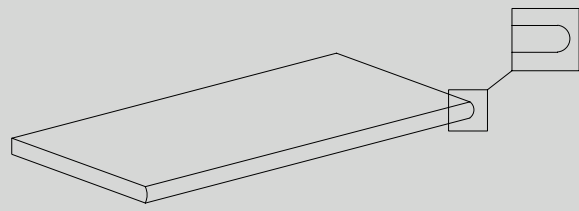

**GRADONE CON TORO 50x100 - 20"x40"**  
GRIP RETT. I 20 ● 297  
GRIP I 20 ● 297

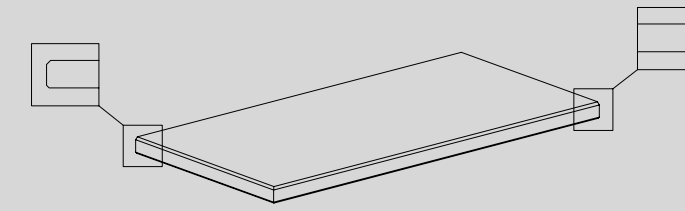

**GRADONE ANGOLARE CON TORO DX/SX 50x100 - 20"x40"**  
GRIP RETT. I 20 ● 337  
GRIP I 20 ● 337

### Geobrick - Pietre Naturali - Graphis

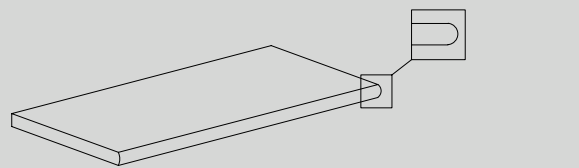

**GRADONE CON TORO 40x80 - 16"x31,5"**  
GRIP RETT. I 20 ● 253

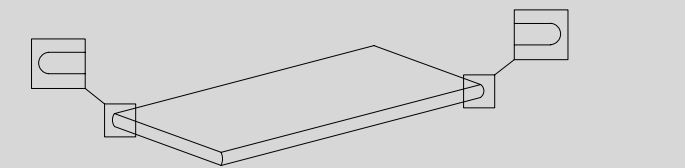

**GRADONE ANGOLARE CON TORO DX/SX 40x80 - 16"x31,5"**  
GRIP RETT. I 20 ● 325

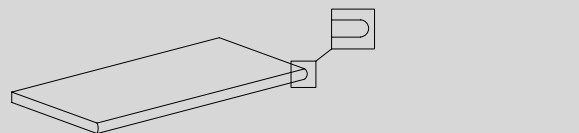

**GRADONE CON TORO 30x60 - 12"x24"**  
GRIP RETT. I 20 ● 149

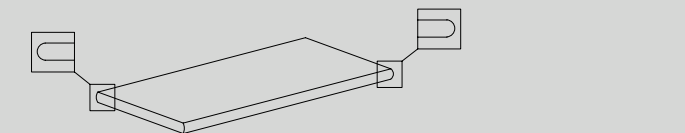

**GRADONE ANGOLARE CON TORO DX/SX 30x60 - 12"x24"**  
GRIP RETT. I 20 ● 233

SUBSTRATES / FONDI / FONDS / GRUNDFLIESEN / SOPORTES					
sizes formati formats Formate formatos		50x100 20"x40"	80x80 31,5"x31,5"	60x60 24"x24"	
	boxes colli boîtes Kartons cajas	pc.	1	1	2
		m <sup>2</sup>	0,5	0,64	0,72
		kg	22,5	29,00	32,7
	pallets pallet palette Paletts paletas	colli	42	40	30
		m <sup>2</sup>	21	25,6	21,6
		kg	945	1160	980

SPECIAL PIECES / PEZZI SPECIALI / PIÈCES SPÉCIALES / FORMSTÜCKE / PIEZAS ESPECIALES								
sizes formati formats Formate formatos		50x100 20"x40" gradone con toro	40x80 16"x31,5" gradone con toro	30x60 12"x24" gradone con toro	50x100 20"x40" gradone angolare con toro DX/SX	40x80 16"x31,5" gradone angolare con toro DX/SX	30x60 12"x24" gradone angolare con toro DX/SX	
	boxes colli boîtes Kartons cajas	pc.	1	1	1	1	1	
		ml	1,0	0,8	0,6	1,0	0,8	0,6
		kg	23,0	14,5	8,0	23,0	14,5	8,0

### Slip - Scivolosità - Glissance - Rutschwert - Adherencia

	Standard Norma Standard   Norm   Norme   Norme	Grip Surface Superficie Grip   Surface Grip Grip Oberflächen   Superficie Grip
		B.C.R.A. (D.M.I. n. 236 μ>0,4)
	ANSI A 326.3 (DCOF WET >0,42)	> 0,42
	DIN EN 16165 ANNEX B	R11
	DIN EN 16165 ANNEX A	A+B+C
	BS EN 16165 ANNEX C	≥ 36 Dry / ≥ 36 Wet
	AS 4586	Class P4

# Index

- The Company
- Technology
- Sizes
- Thicknesses
- Surfaces
- Porcelain stoneware
- Ecologycare
- Certifications
- Quality and Safety
- Ceramic of Italy
- Fincibec Group
- Campus
- Engineering
- Pools & Wellness
- Facades
- Raised Flooring
- Technical Specifications

## Contents by collection

- |           |                 |
|-----------|-----------------|
| Archè     | Geobrick        |
| Ashley    | Graphis         |
| Azimuth   | On Stage        |
| Blade     | Pietra Castello |
| Charisma  | Pietre Naturali |
| Dicta     | Tradition       |
| Dolomite  | Transalp        |
| Esprit    | Woodtime        |
| Evolution | Yukon           |
| Gamut     | <b>Major</b>    |

## Contents by effect

- WOOD - Legno
- MARBLE - Marmo
- STONE - Pietra
- CONCRETE - Cemento

## Color Index

Color Index Major 20mm

# Engineering

## NEW WAYS OF USING CERAMICS.

Fincibec Engineering is a division created by Fincibec Group to provide support services and assistance to resellers, designer, home designers and installers for the specific uses of ceramics.

## NUOVE SOLUZIONI D'IMPIEGO DEL PRODOTTO CERAMICO.

Fincibec Engineering è una struttura creata dal Gruppo Fincibec per fornire un servizio di supporto ed assistenza a rivenditori, progettisti, home designer ed installatori, in relazione ad impieghi particolari della ceramica.

## NOUVELLES SOLUTIONS POUR L'UTILISATION DES PRODUITS DE CARRELAGE.

Fincibec Engineering est une structure créée par le Groupe Fincibec pour fournir un service de soutien et d'assistance aux revendeurs, concepteurs, décorateurs d'intérieur et carreleurs pour tout ce qui concerne les emplois particuliers de la céramique.

## NEUE ANWENDUNGSMETHODEN FÜR KERAMIKPRODUKTE.

Fincibec Engineering ist eine Struktur, die durch die Fincibec Gruppe entwickelt wurde und Unterstützung für Händlern, Designer, Gestalter und Installateure bei der Anwendung von Keramikfliesen liefert.

## NUEVAS SOLUCIONES PARA EL USO DEL PRODUCTO CERÁMICO.

Fincibec Engineering es una estructura creada por el Grupo Fincibec para proporcionar un servicio de soporte y asistencia a minoristas, diseñadores, diseñadores de casas e instaladores, en relación con usos particulares de la cerámica.

★ ★ ★ ★  
**MONOCIBEC**  
FINCIBEC GROUP



Fincibec Group makes available its technical division to support the planner from the design to construction phase. Fincibec's desire has always been to offer an optimum service to its clients, ensuring a high technological level of the materials proposed, refined aesthetic research and also adding a design support service to these two fundamental aspects. By doing so, the client and the architect are free to choose the materials to use for the design in the awareness and safety of a technical division that always meets every need.

Fincibec professionals, supported in the design and structural part by specialist sector companies, are prepared to support and advise the client in choosing the products up to selecting the optimal technical solution to obtain the technical and aesthetic performance of each design.

Le groupe Fincibec met à disposition du concepteur sa division technique pour l'épauler et le supporter depuis la phase de conception jusqu'à celle de la réalisation. La volonté de Fincibec est toujours celle d'offrir le service maximum à ses clients avec l'assurance d'un niveau technologique élevé en termes de matériaux proposés, une recherche esthétique raffinée et, en complément de ces deux aspects, essentiels, également un service d'aide à la conception. Ainsi, le client et l'architecte sont libres de choisir les matériaux à employer pour leur projet avec la conscience et l'assurance d'une division technique toujours prête à répondre aux exigences qui pourront se présenter.

Les professionnels de Fincibec, assistés par des sociétés spécialisées du secteur pour la partie conceptuelle et structurelle, sont préparés pour aider et conseiller le client à partir du choix des produits jusqu'à la sélection de la solution optimale afin d'obtenir des prestations techniques et esthétiques maximales pour chaque type de projet.

Die Gruppe Fincibec stellt die eigene technische Abteilung zur Verfügung, um Designern von der Planung bis zur Herstellung zu helfen und sie zu unterstützen. Fincibec möchte stets in der Lage sein, seinen Kunden den besten Service zu bieten und dabei einen hohen technologischen Stand der Materialie und eine raffinierte Ästhetik garantieren und zur Ergänzung dieser beiden grundlegenden Aspekte, außerdem ein Service zur Unterstützung bei der Planung. Auf diese Weise können der Kunde und der Architekt frei die Materialien für das Projekt wählen, mit dem Verständnis und der Sicherheit eines technischen Bereichs, der stets bemüht ist, die entstehenden Anforderungen zu erfüllen.

Die Fachkräfte von Fincibec, die bei der Planung und Struktur mitarbeiten, kommen von Unternehmen, die auf den Sektor spezialisiert sind und sind vorbereitet, um die Kunden bei der Wahl der Produkte bis zur Wahl der optimalen technischen Lösung zu unterstützen und zu beraten, um die besten technischen und ästhetischen Ergebnisse für jeden Projekttyp zu erhalten.

Il gruppo Fincibec mette a disposizione la sua divisione tecnica per affiancare e supportare il progettista dalla fase di progettazione a quella di realizzazione. La volontà di Fincibec è sempre quella di poter offrire il massimo servizio ai suoi clienti assicurando un alto livello tecnologico dei materiali proposti, una ricerca estetica raffinata e aggiungendo a questi due fondamentali aspetti anche un servizio di supporto alla progettazione. In questo modo il cliente e l'architetto possono scegliere in piena libertà i materiali da usare per il progetto con la consapevolezza e la sicurezza di una divisione tecnica sempre pronta a rispondere alle esigenze che si potranno manifestare.

I professionisti di Fincibec, coadiuvati per la parte progettuale e strutturale da aziende specializzate del settore, sono preparati per affiancare e consigliare il cliente dalla scelta dei prodotti fino alla selezione della soluzione tecnica ottimale al fine di ottenere prestazioni tecniche ed estetiche massime per ogni tipo di progetto.

El grupo Fincibec pone a disposición su división técnica para colaborar y apoyar al proyectista desde la fase de proyección a la de realización. Fincibec tiene siempre la voluntad de ofrecer el máximo servicio a sus clientes asegurando el elevado nivel tecnológico de los materiales que propone, una investigación estética refinada y, añadido a estos dos fundamentales aspectos, un servicio de apoyo a la protección. De esta forma, el cliente y el arquitecto pueden elegir con plena libertad los materiales a usar para el proyecto con la conciencia y la seguridad de tener una división técnica siempre lista para responder a las exigencias que puedan surgir.

Los profesionales de Fincibec, en colaboración con empresas especializadas del sector en la parte de proyección y de estructura, están preparados para apoyar y aconsejar a su clientela desde la elección de los productos hasta la selección de la solución técnica óptima, a fin de obtener unas prestaciones técnicas y estéticas máximas para cada tipo de proyecto.

# Index

The Company  
Technology  
Sizes  
Thicknesses  
Surfaces  
Porcelain stoneware  
Ecologycare  
Certifications  
Quality and Safety  
Ceramic of Italy  
Fincibec Group  
Campus  
**Engineering**  
Pools & Wellness  
Facades  
Raised Flooring  
Technical Specifications

## Contents by collection

Archè	Geobrick
Ashley	Graphis
Azimuth	On Stage
Blade	Pietra Castello
Charisma	Pietre Naturali
Dicta	Tradition
Dolomite	Transalp
Esprit	Woodtime
Evolution	Yukon
Gamut	Major

## Contents by effect

WOOD - Legno  
MARBLE - Marmo  
STONE - Pietra  
CONCRETE - Cemento

## Color Index

Color Index Major 20mm



La volonté de répondre aux exigences des utilisateurs et des concepteurs de piscines et espaces bien-être a conduit Monocibec à développer un programme spécifique entièrement dédié à ce secteur. Une vaste gamme de carreaux spéciaux et de mosaïques assortis aux sols et aux revêtements Monocibec, tant dans des épaisseurs traditionnelles (9-10 mm) que dans des épaisseurs supérieures (20 mm) a été prévue. De cette manière, le client peut obtenir la continuité de l'espace entre le revêtement de sol intérieur et celui extérieur et les pièces spéciales en bord de piscine, jusqu'au revêtement intérieur du bassin, pour une meilleure esthétique. Les matériaux proposés par Monocibec représentent la solution optimale pour les piscines, les espaces bien-être et les zones adjacentes à celles-ci dans la mesure où ils garantissent sécurité, hygiène, esthétique raffinée, facilité d'entretien et de nettoyage, durée, antidérapant, résistance en cas de contact avec des produits chimiques, résistance au gel et à l'absorption. Fincibec Engineering se tient à disposition du client pour développer un projet sur mesure avec tous les détails techniques permettant d'accélérer également les phases de pose sur le chantier. Le service offert a été conçu pour avoir un résultat optimal, grâce au contrôle constant de nos techniciens, du devis à l'envoi du matériel, ce qui permet de réduire les temps et les coûts. Toutes les demandes peuvent être transmises à : [engineering@fincibec.it](mailto:engineering@fincibec.it) / tél. 390536861300.

Der Wunsch, den Anforderungen der Nutzer und Planer von Schwimmbädern und Wellnessbereichen gerecht zu werden, hat Monocibec dazu veranlasst, ein spezifisches Programm zu entwickeln, das ausschließlich diesem Sektor gewidmet ist. Die große Wahl an verschiedenen den Boden- und Wandbelägen von Monocibec passenden Formteilen sind sowohl in traditioneller (9-10 mm) als auch in erhöhter Stärke (20 mm) verfügbar. Auf diese Weise kann der Kunde die räumliche und ästhetische Kontinuität zwischen dem Innen- und Außenbelag und den Formteilen am Beckenrand gewährleisten, sogar bis hin zur Innenverkleidung des Beckens in derselben Ausführung. Die von Monocibec angebotenen Materialien sind die optimale Lösung für Schwimmbäder, Wellness- und angrenzende Bereiche, da sie Sicherheit, Hygiene, optische Raffinesse, einfache Pflege und Reinigung, Langlebigkeit, Rutschfestigkeit, Beständigkeit gegen den Kontakt mit chemischen Produkten, Saugfähigkeit und Frostbeständigkeit garantieren. Fincibec Engineering ist in der Lage, ein maßgeschneidertes Projekt mit allen technischen Details zu entwickeln, um die Installationsphasen vor Ort zu beschleunigen. Der von uns angebotene Service ist auf optimale Ergebnisse ausgerichtet, dank der ständigen Kontrolle durch unsere Techniker von der Angebotsphase bis zum Versand des Materials und der damit verbundenen Zeit- und Kostenersparnis. Alle Anfragen können weitergeleitet werden an: [engineering@fincibec.it](mailto:engineering@fincibec.it) / Tel. 390536861300.

La voluntad de satisfacer las exigencias de los usuarios y de los proyectistas de piscinas y áreas wellness ha llevado al desarrollo por parte de Monocibec de un programa específico totalmente dedicado a este sector. Se ha previsto una amplia gama de piezas especiales y mosaicos que pueden combinarse con pavimentos y revestimientos Monocibec, ya sea en espesor tradicional (9-10 mm) o bien aumentado (20 mm). De este modo, el cliente puede disfrutar de la continuidad a nivel de espacio y estética entre pavimento interno, externo y piezas especiales en los bordes de la piscina, incluyendo el revestimiento interno de la piscina del mismo acabado. Los materiales propuestos por Monocibec representan las soluciones perfectas para piscinas, zonas wellness y las áreas adyacentes a las mismas, puesto que aseguran seguridad, higiene, elegancia estética, sencillez de mantenimiento y limpieza, duración, resistencia al deslizamiento y al contacto con productos químicos, baja absorción de agua, no heladicidad. Fincibec Engineering está a disposición para desarrollar un proyecto a medida con todos los detalles técnicos adecuados para agilizar incluso las fases de colocación en obra. El servicio brindado se ha ideado para obtener un resultado excelente, gracias al constante control de nuestros técnicos, de la fase de elaboración del presupuesto a la de envío del material, con la consiguiente reducción de tiempo y de costes. Todos los pedidos pueden ser enviados a: [engineering@fincibec.it](mailto:engineering@fincibec.it) / tél. 390536861300.



**Fincibec is a member of ASSOPISCINE**  
**Fincibec è socia di ASSOPISCINE**  
 Fincibec est membre de ASSOPISCINE  
 Fincibec ist Mitglied von: ASSOPISCINE  
 Fincibec es socio de ASSOPISCINE



## Pools & Wellness

The desire to meet the demands of users and designers of swimming pools and wellness areas has led Monocibec to develop a specific program entirely dedicated to this sector. A wide range of special pieces and mosaics is available to match Monocibec floors and coverings, both in standard thicknesses (9-10mm) and Major (20mm). In this way the customer can enjoy the spatial and aesthetic continuity between the interior flooring, external flooring and poolside trim, continuing even to the inner lining of the pool in the same finish. The materials developed by Monocibec represent the optimal solution for swimming pools, wellness zones and areas adjacent to them, as they ensure safety, hygiene, aesthetic refinement, easy maintenance and cleaning, durability, slip resistance, resistance to contact with chemicals, impermeability and frost resistance. Fincibec Engineering is available to develop a tailored project with all the technical details necessary to accelerate the phases of installation on site. Our service is designed to provide an optimum result thanks to constant checking by our technicians, from the estimate phase to delivery of the materials, thereby reducing time and cost. All requests may be forwarded to: [engineering@fincibec.it](mailto:engineering@fincibec.it) / tel. (+39) 0536861300.

La volontà di soddisfare le richieste dei fruitori e dei progettisti di piscine e aree wellness ha portato Monocibec a sviluppare un programma specifico interamente dedicato a questo settore. È stata prevista una vasta gamma di pezzi speciali e mosaici da abbinare ai pavimenti e rivestimenti Monocibec, sia in spessore tradizionale (9-10 mm) che maggiorato (20 mm). In questo modo il cliente può godere della continuità spaziale ed estetica tra pavimento interno, esterno e pezzi speciali a bordo vasca, spingendosi fino al rivestimento interno alla vasca della stessa finitura. I materiali proposti da Monocibec rappresentano la soluzione ottimale per le piscine, le zone wellness e le aree a queste adiacenti in quanto garantiscono sicurezza, igiene, raffinatezza estetica, praticità di manutenzione e pulizia, durata, antiscivolo-sità, resistenza al contatto con prodotti chimici, inassorbienza e ingelività. Fincibec Engineering è a disposizione per sviluppare un progetto su misura con tutti i dettagli tecnici atti a velocizzare anche le fasi di posa in cantiere. Il servizio offerto è stato pensato per avere un risultato ottimale, grazie al costante controllo dei nostri tecnici dalla fase di preventivazione a quella di invio del materiale, con conseguente riduzione di tempi e costi. Tutte le richieste possono essere inoltrate a: [engineering@fincibec.it](mailto:engineering@fincibec.it) / tel. 390536861300.

## Index

- The Company
- Technology
- Sizes
- Thicknesses
- Surfaces
- Porcelain stoneware
- Ecologycare
- Certifications
- Quality and Safety
- Ceramic of Italy
- Fincibec Group
- Campus
- Engineering
- Pools & Wellness**
- Facades
- Raised Flooring
- Technical Specifications

### ➤ Contents by collection

Archè	Geobrick
Ashley	Graphis
Azimuth	On Stage
Blade	Pietra Castello
Charisma	Pietre Naturali
Dicta	Tradition
Dolomite	Transalp
Esprit	Woodtime
Evolution	Yukon
Gamut	Major

### ➤ Contents by effect

WOOD - Legno  
 MARBLE - Marmo  
 STONE - Pietra  
 CONCRETE - Cemento

### ➤ Color Index

Color Index Major 20mm



Le programme Façades de Monocibec unit esthétique et technique. Le niveau de qualité élevé fixé par l'entreprise, associé à la fiabilité technique, est la caractéristique fondamentale du programme dédié aux façades aérées et collées, lancé par Monocibec. La diversité des surfaces et des formats proposés, es différents systèmes de fixation présents, la possibilité d'avoir de nombreux avantages, comme les économies d'énergie et un meilleur confort thermo-hygrométrique, font de la façade revêtue de grès fin cérame Monocibec la meilleure solution, pour les constructions neuves comme pour les bâtiments rénovés. Les systèmes de fixation, fournis en collaboration avec des entreprises ayant plusieurs années d'expérience dans ce secteur, sont nombreux et adaptés à toute exigence de conception et de budget. Ceux-ci peuvent être soit apparents soit invisibles et associés à une série d'accessoires.

Im Programm Facades von Monocibec werden Schönheit und Technik vereint. Der hohe Qualitätsstandard, der vom Unternehmen angestrebt wird sowie technische Zuverlässigkeit liegen dem Programm der belüfteten und verklebten Fassaden zugrunde, die von Monocibec eingeführt wurden. Vielfältige Oberflächen und Formate und verschiedene Befestigungsmöglichkeiten bieten zahlreiche Vorteile, wie beispielsweise Energieeinsparung und verbessertes Wärme- und feuchtetechnisches Verhalten, wodurch Fassaden, die mit Feinsteinzeug von Monocibec verkleidet wurden, die beste Lösung für Neubauten und Renovierungen sind. Die zahlreichen Befestigungssysteme, die in Zusammenarbeit mit Unternehmen, die eine langjährige Erfahrung in diesem Bereich aufweisen, angeboten werden, eignen sich für jedes Projektbedürfnis und Budget. Es gibt sie in versenkter und sichtbarer Ausführung und es sind verschiedene Zubehörteilen erhältlich.

La estética y la técnica se fusionan en el programa Facades de Monocibec. El elevado estándar cualitativo que persigue la empresa, combinado con la fiabilidad técnica, constituyen la base del programa relativo a las fachadas ventiladas y pegadas lanzado por Monocibec. La variedad de superficies y formatos propuestos, los diferentes sistemas de fijación, la posibilidad de obtener numerosas ventajas, tales como el ahorro energético y el mayor bienestar termohigrométrico, hacen que la fachada revestida con grés fino porcelánico Monocibec sea la mejor solución tanto para las construcciones nuevas como para la rehabilitación de edificios existentes. Los sistemas de fijación, que se suministran en colaboración con empresas con una experiencia plurianual en el sector, son numerosos y resultan adecuados para cualquier exigencia de diseño y presupuesto; pueden ser a la vista como ocultos y van acompañados de una serie de accesorios.

## Facades

Aesthetics and technology come together in the Monocibec Façades programme. The high quality standards maintained by the company combined with our technical reliability form the basis of our programme for ventilated and bonded façades. The variety of surfaces and sizes offered, the various available installation systems, the possibility to enjoy many advantages, such as energy savings and greater thermo hygrometric benefits, make the Monocibec façades covered with fine porcelain stoneware the best solution for both new constructions and for renovation of existing buildings. The installation systems, provided in partnership with companies with many years of experience in the sector, are numerous and are suitable for any project and budget; they may be either visible or retractable and come provided with a series of accessories.

–

## Facciate

L'estetica e la tecnica si fondono nel programma Facades di Monocibec. L'alto standard qualitativo perseguito dall'azienda abbinato all'affidabilità tecnica sono alla base del programma riguardante facciate ventilate e incollate lanciato da Monocibec. La varietà di superfici e formati proposti, i diversi sistemi di fissaggio presenti, la possibilità di avere numerosi vantaggi, come il risparmio energetico e il maggior benessere termohigrometrico, fanno della facciata rivestita con gres fine porcellanato Monocibec la soluzione migliore sia per nuove costruzioni che per ristrutturazioni di edifici esistenti. I sistemi di fissaggio, forniti in collaborazione con aziende di pluriennale esperienza nel settore, sono numerosi e adatti ad ogni esigenza progettuale e di budget; possono essere sia a vista che a scomparsa e corredati da una serie di accessori.

## Index

The Company  
Technology  
Sizes  
Thicknesses  
Surfaces  
Porcelain stoneware  
Ecologycare  
Certifications  
Quality and Safety  
Ceramic of Italy  
Fincibec Group  
Campus  
Engineering  
Pools & Wellness  
**Facades**  
Raised Flooring  
Technical Specifications

### ➤ Contents by collection

Archè	Geobrick
Ashley	Graphis
Azimuth	On Stage
Blade	Pietra Castello
Charisma	Pietre Naturali
Dicta	Tradition
Dolomite	Transalp
Esprit	Woodtime
Evolution	Yukon
Gamut	Major

### ➤ Contents by effect

WOOD - Legno  
MARBLE - Marmo  
STONE - Pietra  
CONCRETE - Cemento

### ➤ Color Index

Color Index Major 20mm

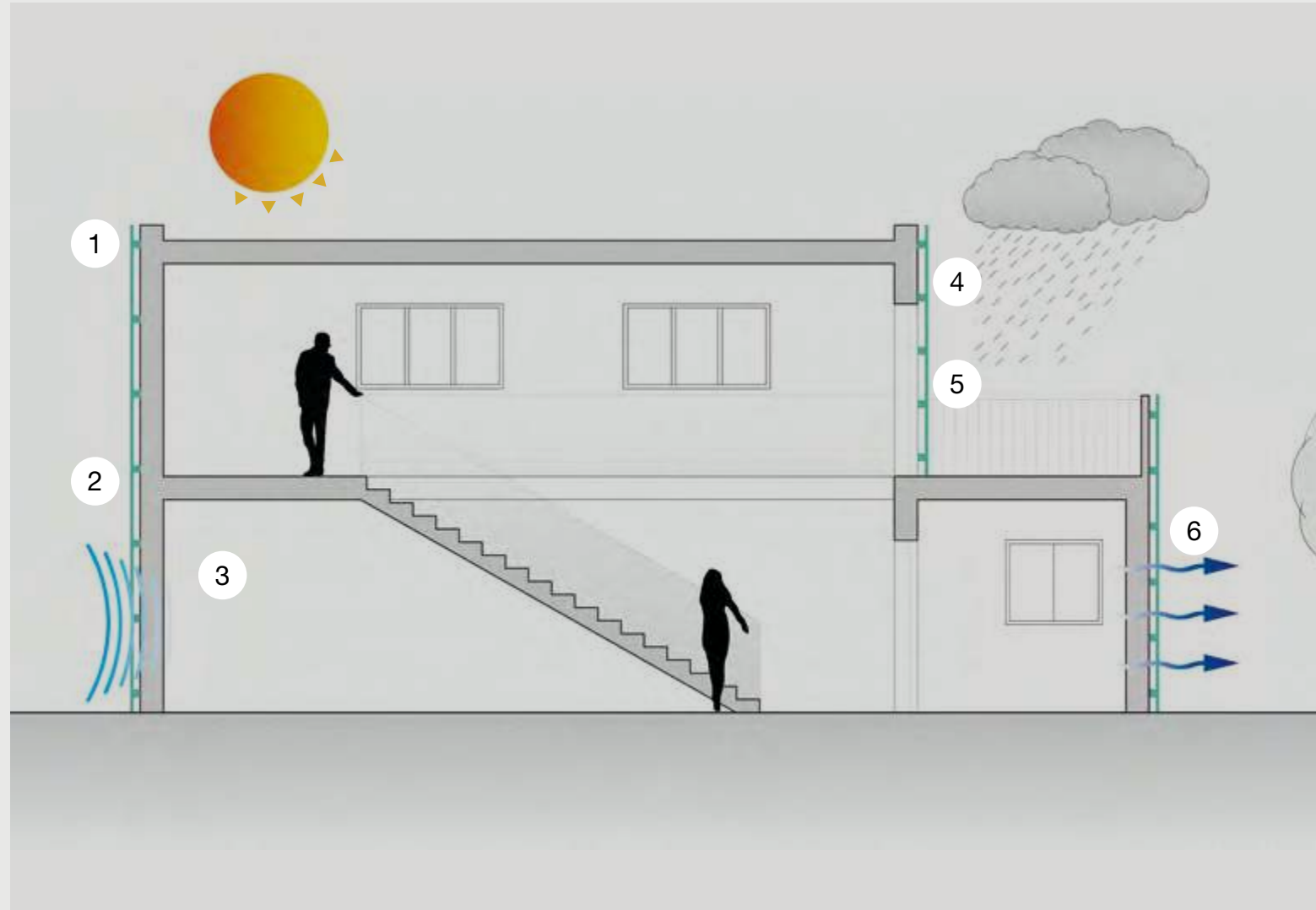

- 1**



**Thermal insulation**  
 Isolamento termico  
 Isolation thermique  
 Wärmedämmung  
 Aislamiento térmico
- 2**



**Chimney effect**  
 Effetto camino  
 Effet cheminée  
 Kamineffekt  
 Efecto chimenea
- 3**

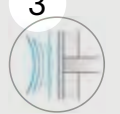

**Sound insulation**  
 Isolamento acustico  
 Isolation acoustique  
 Schalldämmung  
 Aislamiento acústico
- 4**

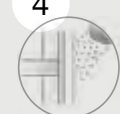

**Protection from weather**  
 Protezione dagli agenti atmosferici  
 Protection contre les agents atmosphériques  
 Schutz vor Witterung  
 Protección frente a los agentes atmosféricos
- 5**



**Service space for housing and control of the systems**  
 Vano tecnico per alloggiamento e controllo di impianti  
 Compartiment technique pour logement et contrôle des systèmes  
 Raum für technische Anlage und Steuerung  
 Compartimiento técnico para instalación y control de equipos
- 6**

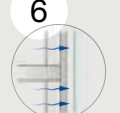

**Reduction of moisture and condensation**  
 Riduzione umidità e condensa  
 Réduction de l'humidité et de la condensation  
 Verminderung von Feuchtigkeit und Kondenswasser  
 Reducción de humedad y agua de condensación



The collaboration with specialized companies also allows us to guarantee the customer the design of the façade, the supply of materials and the final installation on-site.  
 engineering@fincibec.it / tel. 390536861300.

La collaborazione con aziende specializzate consente, di assicurare al cliente la progettazione a norma della facciata, la fornitura dei materiali e l'eventuale posa in cantiere. Tutte le richieste possono essere inoltrate a:  
 engineering@fincibec.it / tel. 390536861300.

La collaboration avec des entreprises spécialisées permet, de plus, de garantir au client la conception de la façade, selon les normes, la fourniture des matériaux et l'éventuelle pose sur le chantier.  
 Toutes les demandes peuvent être transmises à :  
 engineering@fincibec.it / tél. 390536861300.

Durch die Zusammenarbeit mit Fachunternehmen können dem Kunden normgerechte Fassaden sowie unter dem Standpunkt der Materiallieferungen als auch der eventuellen Verlegung auf der Baustelle, garantiert werden.  
 Bitte senden Sie Ihre Anfragen an:  
 engineering@fincibec.it / Tel.: +390536861300.

La colaboración con empresas especializadas también permite asegurar al cliente el diseño según normativa de la fachada, el suministro de materiales y la eventual colocación en obra.  
 Todos los pedidos pueden ser enviados a:  
 engineering@fincibec.it / tel. 390536861300.

# Index

- The Company
- Technology
- Sizes
- Thicknesses
- Surfaces
- Porcelain stoneware
- Ecologycare
- Certifications
- Quality and Safety
- Ceramic of Italy
- Fincibec Group
- Campus
- Engineering
- Pools & Wellness
- Facades**
- Raised Flooring
- Technical Specifications

## ➤ Contents by collection

- |           |                 |
|-----------|-----------------|
| Archè     | Geobrick        |
| Ashley    | Graphis         |
| Azimuth   | On Stage        |
| Blade     | Pietra Castello |
| Charisma  | Pietre Naturali |
| Dicta     | Tradition       |
| Dolomite  | Transalp        |
| Esprit    | Woodtime        |
| Evolution | Yukon           |
| Gamut     | Major           |

## ➤ Contents by effect

- WOOD - Legno
- MARBLE - Marmo
- STONE - Pietra
- CONCRETE - Cemento

## ➤ Color Index

Color Index Major 20mm



## Sols surélevés

Monocibec aborde le thème des sols surélevés pour intérieur et extérieur, en offrant une large gamme de finitions et de tailles différentes, en plus des 60 cm x 60 cm plus traditionnels. Dans ce cas, en plus d'être esthétiquement raffiné, le sol acquiert également un caractère nettement fonctionnel ; le local technique qui est créé sous le sol peut être utilisé pour abriter divers équipements des installations et pour améliorer le confort de vie. Toutes les exigences liées à l'entretien, à la modification ou à la mise à jour des installations et aux différentes organisations des espaces peuvent être satisfaites par le sol surélevé Monocibec.

## Doppelböden

Monocibec widmet sich dem Thema Doppelböden für den Innen- und Außenbereich mit einer breiten Palette an Ausführungen und vielen Formaten zusätzlich zur traditionellen Größe 60 cm x 60 cm. Der Boden ist in diesem Fall nicht nur ästhetisch ansprechend, sondern erlangt auch einen betont funktionellen Charakter. Der technische Raum, der unter dem Bodenbelag entsteht, kann für verschiedene Anlageneinrichtungen und zur Verbesserung des Wohnkomforts genutzt werden. Doppelböden von Monocibec erfüllen alle Anforderungen im Zusammenhang mit Wartung, Änderungen oder Erneuerung der Anlagen und mit einer anderen Raumaufteilung.

## Suelos Elevados

Monocibec aborda el tema de los suelos elevados para interiores y exteriores, ofreciendo una amplia gama de acabados y diferentes formatos, además de los más tradicionales 60 cm x 60 cm. En este caso, además de ser estéticamente refinado, el suelo también adquiere un carácter claramente funcional; el compartimento técnico que se crea debajo del suelo se puede utilizar para albergar diversos equipos de la planta y mejorar la comodidad de la vida. El suelo elevado de Monocibec puede satisfacer todas las necesidades relacionadas con el mantenimiento, la modificación o la actualización de los sistemas y la diferente organización de los espacios.

## Raised Flooring

Monocibec deals in outdoor and indoor raised floors, offering a broad range of finishes and different sizes in addition to the more conventional 60 cm x 60 cm. In this case, besides looking refined, the floor also becomes decidedly functional; you can use the technical compartment that is created below the floor to house various system elements and to improve living comfort. Monocibec raised flooring can meet all needs linked to servicing, changing or updating the systems and arranging spaces differently.

## Pavimenti Sopraelevati

Monocibec affronta il tema dei pavimenti sopraelevati da interno e da esterno, proponendo una vasta gamma di finiture e diversi formati, in aggiunta al più tradizionale 60 cm x 60 cm. In questo caso il pavimento oltre ad essere esteticamente raffinato acquista anche un carattere spiccatamente funzionale; il vano tecnico che viene a crearsi sotto alla pavimentazione può essere utilizzato per alloggiare diverse dotazioni impiantistiche e per migliorare il comfort abitativo. Tutte le esigenze legate alla manutenzione, alla modifica o all'aggiornamento degli impianti e alla diversa organizzazione degli spazi possono essere soddisfatte dal pavimento sopraelevato Monocibec.

## Index

The Company  
Technology  
Sizes  
Thicknesses  
Surfaces  
Porcelain stoneware  
Ecologycare  
Certifications  
Quality and Safety  
Ceramic of Italy  
Fincibec Group  
Campus  
Engineering  
Pools & Wellness  
Facades  
**Raised Flooring**  
Technical Specifications

### > Contents by collection

Archè	Geobrick
Ashley	Graphis
Azimuth	On Stage
Blade	Pietra Castello
Charisma	Pietre Naturali
Dicta	Tradition
Dolomite	Transalp
Esprit	Woodtime
Evolution	Yukon
Gamut	Major

### > Contents by effect

WOOD - Legno  
MARBLE - Marmo  
STONE - Pietra  
CONCRETE - Cemento

### > Color Index

Color Index Major 20mm

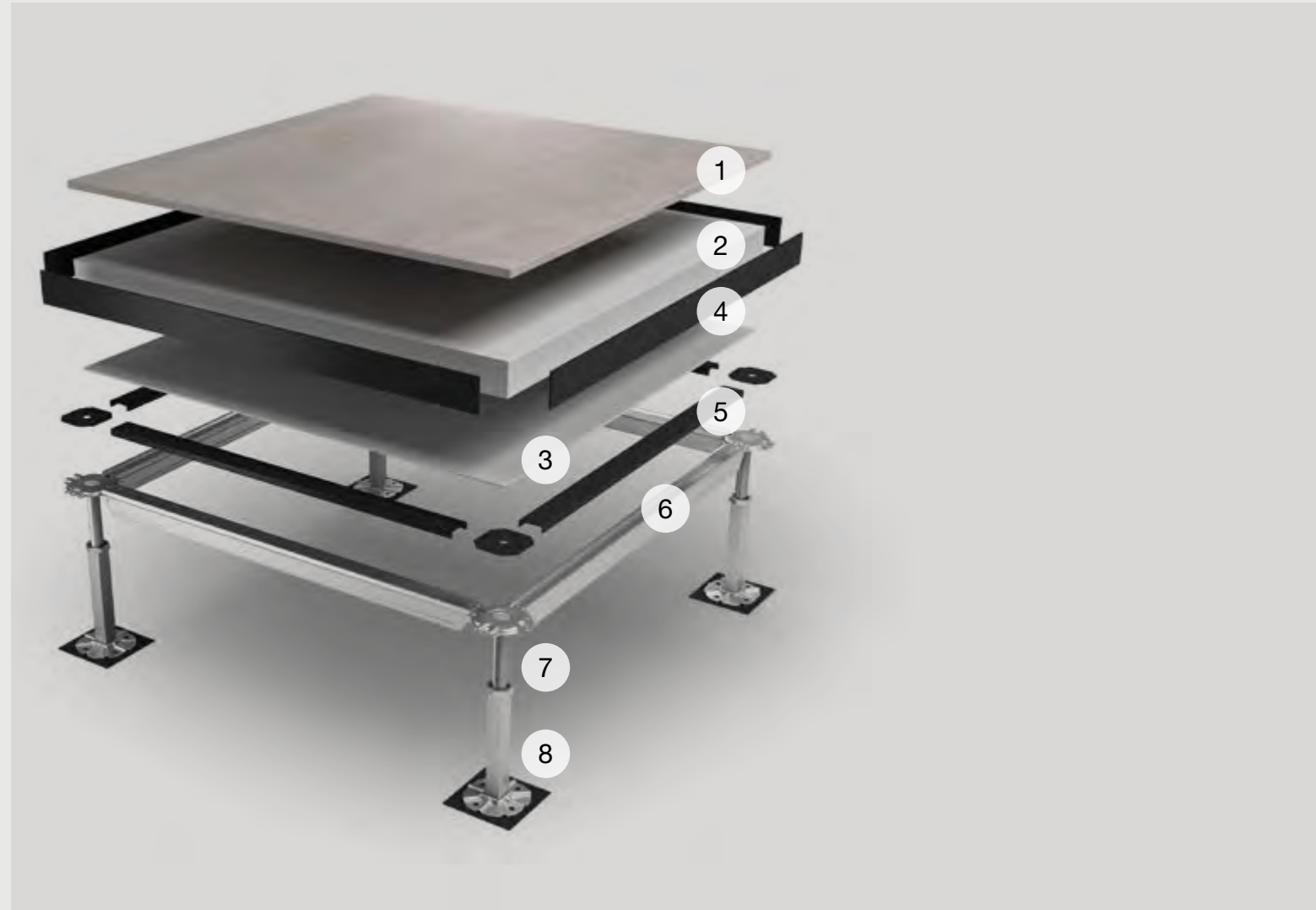

1

**Porcelain stoneware**  
Gres porcellanato  
Grès cérame  
Feinsteinzeug  
Gres porcelánico

2

**A Supporting Soul**  
Anima di supporto  
Âme de soutien  
Stützträger Untere  
Alma de soporte

3

**Lower finish (underfacing)**  
Finitura inferiore  
Structurelle finition  
Ausführung  
Acabado inferior

4

**Perimeter edging**  
Bordo perimetrale  
Inférieure bord de pourtour  
Außenrand Dichtung  
Borde perimetral

5

**Member sealing**  
Guarnizione  
Garniture  
Querträger  
Junta viga

6

**Cross piece**  
Traverso  
Traverse  
Querbalke  
Cadeado

7

**Adjustable bases**  
Colonne regolabili  
Colonnes réglables  
Verstellbar Stützen  
Columnas ajustables

8

**Sound absorbing sheat**  
Materassino fono assorbente  
Gaine insonorisante  
Schallschluckende folie  
Recubrimiento insonorizante



The beauty and technical quality of Monocibec products together with support from Fincibec Engineering let planners and customers develop rooms with complete creative freedom.

You can send any requests to:  
[engineering@fincibec.it](mailto:engineering@fincibec.it) / tel. (+39) 0536861300.

La beauté et la qualité technique des produits Monocibec ainsi que le soutien de Fincibec Engineering permettent au concepteur et au client de développer des environnements avec une liberté créative absolue.  
Toutes les demandes peuvent être transmises à :  
[engineering@fincibec.it](mailto:engineering@fincibec.it) / tél. (+39) 0536861300.

Dank der Schönheit und technischen Qualität der Monocibec-Erzeugnisse sowie der Unterstützung von Fincibec Engineering sind der kreativen Freiheit von Planern und Kunden bei der Konzeption der Räume keine Grenzen gesetzt.  
Anfragen können gerichtet werden an:  
[engineering@fincibec.it](mailto:engineering@fincibec.it) / Tel. (+39) 0536861300.

La bellezza e la qualità tecnica dei prodotti monocibec insieme al il supporto di Fincibec Engineering permettono al progettista e al cliente di sviluppare ambienti con assoluta libertà creativa.

Tutte le richieste possono essere inoltrate a:  
[engineering@fincibec.it](mailto:engineering@fincibec.it) / tel. (+39) 0536861300.

La belleza y la calidad técnica de los productos Monocibec junto con el soporte de Fincibec Engineering permiten al proyectista y al cliente desarrollar entornos con absoluta libertad creativa.  
Todas las solicitudes pueden enviarse a:  
[engineering@fincibec.it](mailto:engineering@fincibec.it) / tel. (+39) 0536861300.

# Index

- The Company
- Technology
- Sizes
- Thicknesses
- Surfaces
- Porcelain stoneware
- Ecologycare
- Certifications
- Quality and Safety
- Ceramic of Italy
- Fincibec Group
- Campus
- Engineering
- Pools & Wellness
- Facades
- Raised Flooring**
- Technical Specifications

## Contents by collection

- |           |                 |
|-----------|-----------------|
| Archè     | Geobrick        |
| Ashley    | Graphis         |
| Azimuth   | On Stage        |
| Blade     | Pietra Castello |
| Charisma  | Pietre Naturali |
| Dicta     | Tradition       |
| Dolomite  | Transalp        |
| Esprit    | Woodtime        |
| Evolution | Yukon           |
| Gamut     | Major           |

## Contents by effect

- WOOD - Legno
- MARBLE - Marmo
- STONE - Pietra
- CONCRETE - Cemento

## Color Index

Color Index Major 20mm



**DURABILITY - DURABILITÀ - DURABILITÉ - LANGLEBIGKEIT - DURABILIDAD**

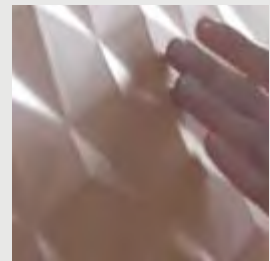

**Easy upkeep**

**KEEP THE LOOKS AND FUNCTION INTACT OVER TIME WITH REGULAR NORMAL CLEANING**

**Facile à entretenir**

MAINTIEN LES CARACTÉRISTIQUES ESTHÉTIQUES ET FONCTIONNELLES INCHANGÉES DANS LE TEMPS AVEC UN NETTOYAGE NORMAL ORDINAIRE

**Pflegeleicht**

MIT EINER GEWÖHNLICHEN REINIGUNG BLEIBEN DIE ÄSTHETISCHEN UND FUNKTIONELLEN MERKMALE IM LAUFE DER ZEIT UNVERÄNDERT ERHALTEN

**Fácil de mantener**

MANTIENE LAS CARACTERÍSTICAS ESTÉTICAS Y FUNCIONALES A LO LARGO DEL TIEMPO CON UNA LIMPIEZA NORMAL ORDINARIA

**Facile da mantenere**

MANTIENE INALTERATE NEL TEMPO LE CARATTERISTICHE ESTETICHE E FUNZIONALI CON UNA NORMALE PULIZIA ORDINARIA



**Resistant to sunlight**

**IN DIRECT CONTACT WITH UV RAYS THE MATERIAL DOES NOT UNDERGO ANY COLOUR CHANGE**

**Résistant à la lumière du soleil**

LE MATÉRIAU EN CONTACT DIRECT AVEC LES RAYONS UV NE SUBIT AUCUNE ALTÉRATION DE COULEUR

**Sonnenbeständig**

DIREKTE UV-EINSTRHLUNG BEWIRKT KEINE FARBVERÄNDERUNG DES MATERIALS

**Resistente ai raggi solari**

**IL MATERIALE A DIRETTO CONTATTO CON I RAGGI UV NON SUBISCE ALCUNA ALTERAZIONE DEI COLORI**

**Resistente a la luz solar**

EL MATERIAL EN CONTACTO DIRECTO CON LOS RAYOS UVA NO SUFRE NINGUNA ALTERACIÓN DE COLOR



**Resistant to chemicals**

**RESISTS CHEMICAL AGENTS AND ACIDS/BASES USED IN THE HOME**

**Résistant aux attaques chimiques**

RÉSISTANT AUX PRODUITS CHIMIQUES ET AUX ACIDES/BASES DOMESTIQUES

**Chemikalienbeständig**

BESTÄNDIG GEGEN CHEMIKALIEN UND SÄUREN/BASEN DES HÄUSLICHEN GEBRAUCHS

**Resistente al ataque químico.**

RESISTENTE A AGENTES QUÍMICOS Y ÁCIDOS / BASES DE HOGAR

**Resistente all'attacco chimico**

**RESISTE AGLI AGENTI CHIMICI E AGLI ACIDI/BASI DI USO DOMESTICO**



**Stain-resistant**

**STAIN-RESISTANT AND THEREFORE EASY TO CLEAN**

**Résistant aux taches**

RÉSISTANT AUX TACHES ET DONC FACILE À NETTOYER

**Fleckbeständig**

UNDURCHLÄSSIG FÜR FLECKEN UND DAHER LEICHT ZU REINIGEN

**Resistente alle macchie**

**IMPERMEABILE ALLE MACCHIE E QUINDI FACILMENTE PULIBILE**

**Resistente a las manchas**

IMPERMEABLE A LAS MANCHAS Y POR LO TANTO, FÁCIL DE LIMPIAR

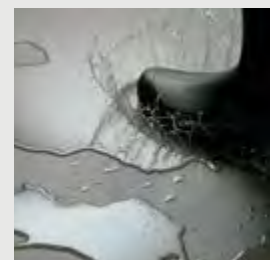

**Impermeable**

**THANKS TO ITS COMPACTNESS THE PORCELAIN STONWARE DOES NOT ABSORB WATER AND DOES NOT SUFFER HUMIDITY**

**Étanche**

GRÂCE À SA COMPACITÉ, LE GRÈS CÉRAME N'ABSORBE PAS L'EAU ET NE CRAINT PAS L'HUMIDITÉ

**Wasserundurchlässig**

DANK SEINER DICHTHE NIMMT FEINSTEINZEUG KEIN WASSER UND KEINE FEUCHTIGKEIT AUF

**Impermeable**

GRACIAS A SU COMPACIDAD, EL GRES PORCELÁNICO NO ABSORBE AGUA Y NO TEME LA HUMEDAD

**Impermeabile**

**GRAZIE ALLA SUA COMPATTEZZA IL GRES PORCELLANATO NON ASSORBE ACQUA E NON TEME L'UMIDITÀ**

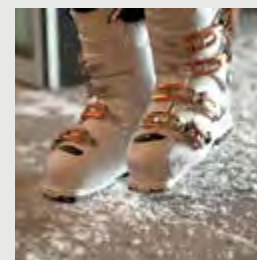

**Resistant to freezing**

**PORCELAIN STONWARE IS FROST-PROOF AND CAN WITHSTAND THE COLDEST CLIMATES**

**Résistant au gel**

LE GRÈS CÉRAME NE PEUT GELÉ ET RÉSISTE AUX CLIMATS LES PLUS RUDES

**Frostbeständig**

FEINSTEINZEUG IST FROSTSICHER UND HÄLT SEHR KALTEM KLIMA STAND

**Resistente al gelo**

**IL GRES PORCELLANATO È INGELIVO E IN GRADO DI RESISTERE AI CLIMI PIÙ RIGIDI**

**Resistente a las heladas**

EL GRES PORCELÁNICO RESISTE AL HIELO Y ES CAPAZ DE SOPORTAR LOS CLIMAS MÁS DUROS



**Resistant to jumps in temperature**

**RESISTS JUMPS IN TEMPERATURE WITHOUT CHANGING**

**Résistant aux changements brusques de température**

RÉSISTE SANS ALTÉRATION AUX BRUSQUES DIFFÉRENCES DE TEMPÉRATURE

**Temperaturbeständig**

BESTÄNDIG GEGEN PLÖTZLICHE TEMPERATURSCHWANKUNGEN

**Resistente a los cambios térmicos**

RESISTE SIN ALTERACIONES A LAS DIFERENCIAS DE TEMPERATURA REPENTINAS

**Resistente agli sbalzi termici**

**RESISTE SENZA ALTERAZIONI ALLE REPENTINE DIFFERENZE DI TEMPERATURE**

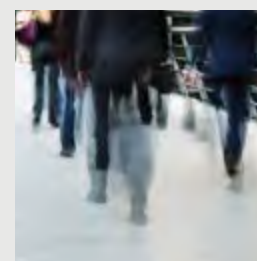

**Strong and unalterable**

**YOU CAN USE PORCELAIN STONWARE TO COVER MANY SURFACES IN RESIDENTIAL AND COMMERCIAL SPACES**

**Résistant et inaltérable**

LE GRÈS CÉRAME PEUT ÊTRE UTILISÉ POUR COUVRIR UNE LARGE GAMME DE SURFACES DANS DES APPLICATIONS RÉSIDENIELLES ET COMMERCIALES

**Widerstandsfähig und unveränderlich**

FEINSTEINZEUG EIGNET SICH FÜR DIE VERKLEIDUNG ZAHLREICHER OBERFLÄCHEN IM WOHNUNGS- UND GEWERBEBAU

**Resistente e inalterabile**

**IL GRES PORCELLANATO PUÒ ESSERE UTILIZZATO PER RIVESTIRE MOLTEPLICI SUPERFICI IN AMBITO RESIDENZIALE E COMMERCIALE**

**Resistente e inalterable**

EL GRES PORCELÁNICO PUEDE UTILIZARSE PARA CUBRIR UNA AMPLIA GAMA DE SUPERFICIES EN APLICACIONES RESIDENCIALES Y COMERCIALES

# Index

- The Company
- Technology
- Sizes
- Thicknesses
- Surfaces
- Porcelain stoneware
- Ecologycare
- Certifications
- Quality and Safety
- Ceramic of Italy
- Fincibec Group
- Campus
- Engineering
- Pools & Wellness
- Facades
- Raised Flooring
- Technical Specifications

## ➤ Contents by collection

- |           |                 |
|-----------|-----------------|
| Archè     | Geobrick        |
| Ashley    | Graphis         |
| Azimuth   | On Stage        |
| Blade     | Pietra Castello |
| Charisma  | Pietre Naturali |
| Dicta     | Tradition       |
| Dolomite  | Transalp        |
| Esprit    | Woodtime        |
| Evolution | Yukon           |
| Gamut     | Major           |

## ➤ Contents by effect

- WOOD - Legno
- MARBLE - Marmo
- STONE - Pietra
- CONCRETE - Cemento

## ➤ Color Index

Color Index Major 20mm

HEALTH - SALUTE - SANTÉ - GESUNDHEIT - SALUD

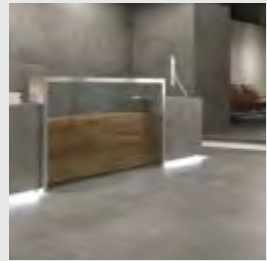

**Zero formaldehyde**

WILL NOT GIVE OFF FORMALDEHYDE EMISSIONS

Sans formaldéhyde

NE LIBÈRE PAS DE FORMALDÉHYDE DANS L'ENVIRONNEMENT

Formaldehydfrei

GIBT KEIN FORMALDEHYD IN DIE UMWELT AB.

Cero formaldehído

NO LIBERA FORMALDEHÍDO EN EL MEDIO AMBIENTE.

**Zero formaldeide**

NON RILASCIA FORMALDEIDE NELL'AMBIENTE.



**Zero vocs**

FINE PORCELAIN STONWARE IS AN INERT MATERIAL THAT DOES NOT EMIT VOLATILE ORGANIC COMPOUNDS (VOC)

Sans COV

LES CARREAUX EN GRÈS CÉRAME SONT UN MATÉRIAU INERTE QUI N'ÉMET PAS DE COMPOSÉS ORGANIQUES VOLATILS (COV)

VOC-frei

FEINSTEINZEUGFLIESEN SIND EIN INERTES MATERIAL UND EMITTIEREN KEINE FLÜCHTIGEN ORGANISCHEN VERBINDUNGEN (VOC)

**Zero vocs**

LE PIASTRELLE IN GRES PORCELLANATO SONO UN MATERIALE INERTE CHE NON EMETTE COMPOSTI ORGANICI VOLATILI (VOC)

Cero vocs

LAS BALDOSAS DE GRES PORCELÁNICO SON UN MATERIAL INERTE QUE NO EMITE COMPUESTOS ORGANICOS VOLÁTILES (VOC).

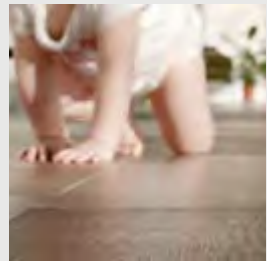

**Anallergic**

CONTAINS NO ALLERGENS

Hypoallergénique

NE CONTIENT PAS D'ALLERGÈNES

Nicht allergen

ENTHÄLT KEINE ALLERGENE

Hipoalergénico

NO CONTIENE ALÉRGENOS

**Anallergico**

NON CONTIENE ALLERGENI



**Odourless**

DOES NOT GIVE OFF ODOURS INDOORS OR OUTDOORS

Inodore

NE DÉGAGE PAS D'ODEURS DANS L'ENVIRONNEMENT INTÉRIEUR ET EXTÉRIEUR

Geruchsfrei

GERUCHSFREI IM INNEN-UND AUSSENBEREICH

Inodoro

NO LIBERA OLORES EN LOS ENTORNOS INTERIORES Y EXTERIORES

**Inodore**

NON RILASCIA ODORI NELL'AMBIENTE INDOOR E OUTDOOR



**Resistant to microbes**

FINE PORCELAIN STONWARE IS AN INERT MATERIAL WHICH INHIBITS GROWTH OF BACTERIA AND FUNGUS

Résistant à la croissance microbienne

LES CARREAUX EN GRÈS CÉRAME SONT UN MATÉRIAU INERTE ET INHIBENT DONC LA CROISSANCE DES BACTÉRIES ET DES CHAMPIGNONS

Kein Wachstum von Mikroorganismen

FEINSTEINZEUGFLIESEN SIND EIN INERTES MATERIAL UND VERHINDERN SOMIT DAS WACHSTUM VON BAKTERIEN UND PILZEN

Resistente al crecimiento microbiano

LAS BALDOSAS DE GRES PORCELÁNICO SON UN MATERIAL INERTE Y POR LO TANTO INHIBEN EL CRECIMIENTO DE BACTERIAS Y HONGOS.

**Resistente alla crescita microbica**

LE PIASTRELLE IN GRES PORCELLANATO SONO UN MATERIALE INERTE E PERTANTO INIBISCONO LA CRESCITA DI BATTERI E FUNGHI



**Easy to clean**

CAN BE CLEANED WITH WATER OR ORDINARY CLEANING PRODUCTS FOR GUARANTEED HYGIENE

Facile à nettoyer

PEUT ÊTRE NETTOYÉ À L'EAU OU AVEC DES DÉTERGENTS COURANTS POUR UNE GARANTIE D'HYGIÈNE SÛRE

Einfach zu reinigen

FÜR EINE SICHERE HYGIENE MIT WASSER ODER GEWÖHNLICHEN REINIGUNGSMITTELN ZU REINIGEN

Fácil de limpiar

LIMPIABLE CON AGUA O DETERGENTES COMUNES PARA UNA GARANTÍA DE HIGIENE SEGURA

**Facile da pulire**

PULIBILE CON ACQUA O DETERGENTI COMUNI PER UNA GARANZIA DI UNA IGIENE SICURA

# Index

- The Company
- Technology
- Sizes
- Thicknesses
- Surfaces
- Porcelain stoneware
- Ecologycare
- Certifications
- Quality and Safety
- Ceramic of Italy
- Fincibec Group
- Campus
- Engineering
- Pools & Wellness
- Facades
- Raised Flooring
- Technical Specifications

## Contents by collection

- |           |                 |
|-----------|-----------------|
| Archè     | Geobrick        |
| Ashley    | Graphis         |
| Azimuth   | On Stage        |
| Blade     | Pietra Castello |
| Charisma  | Pietre Naturali |
| Dicta     | Tradition       |
| Dolomite  | Transalp        |
| Esprit    | Woodtime        |
| Evolution | Yukon           |
| Gamut     | Major           |

## Contents by effect

- WOOD - Legno
- MARBLE - Marmo
- STONE - Pietra
- CONCRETE - Cemento

## Color Index

Color Index Major 20mm

SAFETY - SICUREZZA - SÉCURITÉ - SICHERHEIT - SEGURIDAD



**Fire-resistant**

**FINE PORCELAIN STONWARE TILES ARE INCOMBUSTIBLE, DO NOT BURN, DO NOT GIVE OFF FUMES, AND DO NOT PROPAGATE FLAME IN CASE OF FIRE**

Résistant au feu

LES CARREAUX DE GRÈS CÉRAME SONT INCOMBUSTIBLES, NE BRÛLENT PAS, NE DÉGAGENT PAS DE FUMÉE ET N'ALIMENTENT PAS LA PROPAGATION DES FLAMMES EN CAS D'INCENDIE

Feuerfest

FEINSTEINZEUGFLIESEN SIND NICHT BRENNBAR, ERZEUGEN KEINE DÄMPFE UND GEBEN FLAMMEN IM BRANDFALL KEINE NAHRUNG

Resistente al fuego

LAS BALDOSAS DE GRES PORCELÁNICO SON INCOMBUSTIBLES, NO SE QUEMAN, NO EMITEN HUMO Y NO ALIMENTAN LA PROPAGACIÓN DE LAS LLAMAS EN CASO DE INCENDIO

**Resistente al fuoco**

**LE PIASTRELLE IN GRES PORCELLANATO SONO INCOMBUSTIBILI, NON BRUCIANO, NON EMETTONO FUMI, NE ALIMENTANO LA PROPAGAZIONE DELLE FIAMME IN CASO DI INCENDIO**



**Non-slip**

**FINE PORCELAIN STONWARE SURFACES CAN BE MADE WITH NON-SLIP SURFACES**

Antidérapant

CERTAINES SURFACES EN GRÈS CÉRAME PEUVENT ÊTRE RÉALISÉES AVEC UNE GRANDE RÉSISTANCE AU GLISSEMENT.

Rutschfest

BESTIMTE OBERFLÄCHEN AUS FEINSTEINZEUG WERDEN MIT HOHER RUTSCHHEMMUNG HERGESTELLT.

Antideslizante

ALGUNAS SUPERFICIES DE GRES PORCELÁNICO PUEDEN SER REALIZADAS CON ALTA RESISTENCIA AL DESLIZAMIENTO.

**Antiscivolo**

**ALCUNE SUPERFICI IN GRES PORCELLANATO POSSONO ESSERE REALIZZATE CON UN'ELEVATA RESISTENZA ALLO SCIVOLAMENTO.**



**Unalterable under the effect of heat**  
**FINE PORCELAIN STONWARE HAS LOW THERMAL EXPANSION, MAKING IT IDEAL FOR USE WITH UNDERFLOOR HEATING SYSTEMS**

Inaltérable à la chaleur

LE GRÈS CÉRAME GARANTIT UNE DILATATION THERMIQUE RÉDUITE ET EST IDÉAL POUR LES SYSTÈMES DE CHAUFFAGE AU SOL

Hitzebeständig

FEINSTEINZEUG GEWÄHRLEISTET EINE GERINGE WÄRMEAUSSDEHNUNG UND IST IDEAL FÜR FUSSBODENHEIZUNGEN

Inalterable al calor

EL GRES PORCELÁNICO GARANTIZA UNA REDUCIDA EXPANSIÓN TÉRMICA Y ES IDEAL PARA SISTEMAS DE CALEFACCIÓN POR SUELO RADIANTE.

**Inalterabile al calore**

**IL GRES PORCELLANATO GARANTISCE UNA RIDOTTA ESPANSIONE TERMICA E RISULTA IDEALE PER SISTEMI DI RISCALDAMENTO A PAVIMENTO**

ENVIRONMENT - AMBIENTE - ENVIRONNEMENT - UMWELT - AMBIENTE



**Environmentally sustainable**

**FINE PORCELAIN STONWARE HAS A LOW ENVIRONMENTAL IMPACT THROUGHOUT ITS LIFESPAN, FROM PRODUCTION TO DISPOSAL**

Éco-durable

LE GRÈS CÉRAME A UNE FAIBLE INCIDENCE SUR L'ENVIRONNEMENT, DE LA PHASE DE PRODUCTION À L'ÉLIMINATION DU PRODUIT

Umweltfreundlich

VON DER HERSTELLUNG BIS HIN ZUR ENTSORGUNG HAT FEINSTEINZEUG GERINGE UMWELTAUSWIRKUNGEN

Eco-sostenibile

EL GRES PORCELÁNICO TIENE UN BAJO IMPACTO AMBIENTAL DESDE LA ETAPA DE PRODUCCIÓN HASTA LA ELIMINACIÓN DEL PRODUCTO

**Ecosostenibile**

**IL GRES PORCELLANATO HA UN BASSO IMPATTO AMBIENTALE DALLA FASE DI PRODUZIONE A QUELLA DI SMALTIMENTO DEL PRODOTTO**



**Recycling**

**FINE PORCELAIN STONWARE IS EASILY RECYCLABLE AS IT IS A HOMOGENEOUS PRODUCT MADE OF INERT NATURAL MATERIALS**

Recyclage

LES CARREAUX EN GRÈS CÉRAME SONT FACILEMENT RECYCLABLES EN TANT QUE PRODUITS HOMOGENÈS FABRIQUÉS À PARTIR DE MATÉRIAUX NATURELS INERTES

Recycling

FEINSTEINZEUGFLIESEN SIND LEICHT RECYCELBAR, DA ES HOMOGENE PRODUKTE AUS NATÜRLICHEN INERTEN STOFFEN SIND

Reciclaje

LAS BALDOSAS DE GRES DE PORCELANA SON FÁCILMENTE RECICLABLES COMO PRODUCTOS HOMOGENEOS, COMPUESTOS POR MATERIALES NATURALES INERTES

**Riciclo**

**LE PIASTRELLE IN GRES PORCELLANATO SONO FACILMENTE RICICLABILI IN QUANTO PRODOTTI OMOGENEI, COSTITUITI DA MATERIALI NATURALI INERTI**

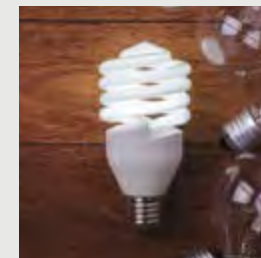

**Efficiency and energy savings**

**FINE PORCELAIN STONWARE SAVES ENERGY THANKS TO ITS THERMAL INERTIA, WHICH REDUCES INDOOR TEMPERATURE EXCURSION**

Efficacité et économie d'énergie

LE GRÈS CÉRAME FAVORISE LES ÉCONOMIES D'ÉNERGIE GRÂCE À SA GRANDE INERTIE THERMIQUE QUI RÉDUIT LES CHANGEMENTS DE TEMPÉRATURE DANS LA PIÈCE.

Energieeffizienz und -einsparung

DANK SEINER HOHEN WÄRMETRÄGHEIT, DIE TEMPERATURSCHWANKUNGEN IN DEN RÄUMEN REDUZIERT, FÖRDERT FEINSTEINZEUG DIE ENERGIEEINSPARUNG.

**Efficienza e risparmio energetico**

**IL GRES PORCELLANATO FAVORISCE IL RISPARMIO ENERGETICO GRAZIE ALL'ELEVATA INERZIA TERMICA CHE RIDUCE GLI SBALZI DI TEMPERATURA DEGLI AMBIENTI.**

Eficiencia y ahorro de energía

EL GRES PORCELÁNICO FAVORECE EL AHORRO DE ENERGÍA GRACIAS A SU ALTA INERCIÁ TÉRMICA, QUE REDUCE LOS CAMBIOS DE TEMPERATURA EN LOS LOCALES.

Index

- The Company
- Technology
- Sizes
- Thicknesses
- Surfaces
- Porcelain stoneware
- Ecologycare
- Certifications
- Quality and Safety
- Ceramic of Italy
- Fincibec Group
- Campus
- Engineering
- Pools & Wellness
- Facades
- Raised Flooring
- Technical Specifications

➤ Contents by collection

- |           |                 |
|-----------|-----------------|
| Archè     | Geobrick        |
| Ashley    | Graphis         |
| Azimuth   | On Stage        |
| Blade     | Pietra Castello |
| Charisma  | Pietre Naturali |
| Dicta     | Tradition       |
| Dolomite  | Transalp        |
| Esprit    | Woodtime        |
| Evolution | Yukon           |
| Gamut     | Major           |

➤ Contents by effect

- WOOD - Legno
- MARBLE - Marmo
- STONE - Pietra
- CONCRETE - Cemento

➤ Color Index

Color Index Major 20mm

Fine porcelain stoneware - Gres fine porcellanato  
Grès cérame fin - Feinsteinzeug - Gres fine porcelánico

## TECHNICAL SPECIFICATIONS INFORMAZIONI TECNICHE

Informations techniques - Technische Informationen  
Informaciones técnicas

★★★★★  
**MONOCIBEC**<sup>®</sup>  
FINCIBEC GROUP

# Index

The Company  
Technology  
Sizes  
Thicknesses  
Surfaces  
Porcelain stoneware  
Ecologycare  
Certifications  
Quality and Safety  
Ceramic of Italy  
Fincibec Group  
Campus  
Engineering  
Pools & Wellness  
Facades  
Raised Flooring  
**Technical Specifications**

## > Contents by collection

Archè	Geobrick
Ashley	Graphis
Azimuth	On Stage
Blade	Pietra Castello
Charisma	Pietre Naturali
Dicta	Tradition
Dolomite	Transalp
Esprit	Woodtime
Evolution	Yukon
Gamut	Major

## > Contents by effect

WOOD - Legno  
MARBLE - Marmo  
STONE - Pietra  
CONCRETE - Cemento

## > Color Index

Color Index Major 20mm

## Slip resistance characteristics

Caratteristiche di resistenza allo scivolamento

Caractéristiques de résistance au glissement - Rutschhemmungsklassen - Características de resistencia al deslizamiento

**Slip resistance.**
**The slip resistance of a surface is a performance factor affecting people safety; this is way it is the subject of a specific technical standard in many countries. As these standards are national, the test methods, requirements and classes vary depending on the country. As currently there is no standard internatio-nally valid, our company has decided to inform about the expected slip resistance level of the various offered lines through a purely indicative value of the classes R (DIN EN 16165 ANNEX B), A+B+C (DIN EN 16165 ANNEX A), DCOF (ANSI A 326.3), BS EN 16165 ANNEX C, AS 4586, BCRA. Obviously, this is a first indication for the selection and not a specific guarantee; the company is available, upon request, to have single lots of the chosen material tested by official laboratories according to the test method specified by the user.**

Résistance au glissement.
La résistance au glissement d’une surface est une qualité qui concerne la sécurité des personnes, c’est pourquoi dans de nombreux pays elle fait l’objet d’une norme technique spécif-ique. Puisqu’il s’agit de normes nationales, les méthodes de test, les qualités requises et les catégories de classification changent d’un pays à l’autre. Étant donné qu’actuellement il n’existe pas de réglementation internationale, notre entreprise a pris la décision de notifier le niveau de résistance au glissement attendu sur les différentes lignes proposées, en utilisant la valeur purement indicative des classes R (DIN EN 16165 ANNEX B), A+B+C (DIN EN 16165 ANNEX A), DCOF (ANSI A 326.3), BS EN 16165 ANNEX C, AS 4586, BCRA. Il s’agit-là d’une première contribution d’orientation au choix et non pas d’une garantie à part entière. La Société propose, sur demande, de faire tester des lots individuels de matériaux par des laboratoires officiels, selon la méthode de test indiquée par l’utilisateur.

The German norms DIN EN 16165 ANNEX A / DIN EN 16165 ANNEX B, AS 4586 and DCOF (ANSI A 326.3) are usually referred to for the anti-slip features of the floors, as these norms have been widely acknowledged in the specifications of the different countries; these norms are summarized here below
I Agli effetti delle proprietà antiscivolo dei pavimenti, si fa normalmente riferimento alle norme DIN EN 16165 ANNEX A / DIN EN 16165 ANNEX B, AS 4586 e DCOF (ANSI A 326.3), largamente recepite nei capitolati di diversi paesi, che in sintesi, riportiamo di seguito
I La détermination des propriétés antidérapantes des sols se réfère aux normes DIN EN 16165 ANNEX A / DIN EN 16165 ANNEX B, AS 4586 et DCOF (ANSI A 326.3), largement reconnues par les lois de nombreux pays, et indiquées brièvement ci-dessous
I In Bezug auf die Rutschfestigkeitseigenschaften der Fußböden wird normalerweise auf die Normen DIN EN 16165 ANNEX A / DIN EN 16165 ANNEX B, AS 4586 und DCOF (ANSI A 326.3) verwiesen, die in vielen Ländern in den Ausschreibungen als Bestandteil gelten. Hier eine kurze Zusammenfassung
I A efectos de las propiedades antideslizantes de los pavimentos, se hace normalmente referencia a las normas DIN EN 16165 ANNEX A / DIN EN 16165 ANNEX B, AS 4586 y ASTM C 1028, de amplia aceptación en las especificaciones de distintos países y que, de manera resumida, indicamos a continuación.

La nuova gamma di linee di pavimento in gres, ceramica e porcellana, è composta da 12 collezioni, di cui 6 in gres e 6 in ceramica.
Le nuove linee di pavimento in gres, ceramica e porcellana, sono composte da 12 collezioni, di cui 6 in gres e 6 in ceramica.

### DIN EN 16165 ANNEX B

Flooring for wet areas to be walked barefoot

Pavimentazione per zone bagnate con calpestio a piedi scalzi

Sols pour zones mouillées avec piétnement à pieds nus

Böden für Nassbereiche, die mit bloßen Füßen betreten werden

Pavimentaciones para zonas mojadas donde se camina con pies descalzos

Risk of slipping <p>Gruppo di qualificazione</p> Risque de glisser Rutschgefahr Riesgo de deslizamiento	Angle of slope <p>Angolo d’inclinazione</p> Angle d’inclinaison Neigungswinkel Ángulo de inclinación	
<b>A</b>	<b>≥ 12°</b>	
<b>B</b>	<b>≥ 18°</b>	
<b>C</b>	<b>≥ 24°</b>	

### DCOF (ANSI A 326.3 2012)

Floorings for wet areas - Pavimentazioni per zone bagnate

Carrelages destinés à des zones humides - Bodenbeläge für den Nass

Pavimentos para zonas mojadas

Wet
<b>&gt; 0,42</b>

### B.C.R.A.

B.C.R.A. (D.M. 236 μ>0.4)
<b>DRY LEATHER - CUOIO ASCIUTTO</b> μ>0.4 <b>WET RUBBER - GOMMA BAGNATA</b> μ>0.4

Resistenza allo scivolamento.
La resistenza allo scivolamento di una superficie è una prestazione che attiene alla sicurezza delle persone; per questo motivo in molti Paesi è oggetto di specifica normativa tecnica. Trattandosi di normative nazionali, i metodi di prova, i requisiti e le classificazioni variano da Paese a Paese. Poiché, allo stato, non esiste una normativa condivisa internazionalmente, la nostra Azienda ha deciso di informare del livello di resistenza allo scivolamento atteso sulle diverse linee proposte, attraverso un va-lore puramente indicativo delle classi R (DIN EN 16165 ANNEX B), A+B+C (DIN EN 16165 ANNEX A), DCOF (ANSI A 326.3), BS EN 16165 ANNEX C, AS 4586, BCRA. Trattasi, come è intuitivo, di un primo contributo all’orientamento nella scelta e non di una specifica garan-zia; l’Azienda è disponibile, su richiesta, a far testare, da laboratori ufficiali singole partite del materiale prescelto secondo il metodo di prova indicato dall’utilizzatore.

Resistencia al deslizamiento.
La resistencia al deslizamiento de una superficie es una prestación que atañe a la seguridad de las personas; por esta razón, en muchos países es objeto de una normativa técnica específica. Al tratarse de normativas nacionales, los métodos de prueba, los requisitos y las clasificaciones varían de un país a otro. Ya que en este momento no existe una normativa compartida a nivel internacional, nuestra empresa ha decidido informar sobre el nivel de resistencia al deslizamiento esperado para las distintas líneas propuestas, mediante un valor puramente indicativo de las clases R (DIN EN 16165 ANNEX B), A+B+C(DIN EN 16165 ANNEX A), DCOF (ANSI A 326.3), BS EN 16165 ANNEX C, AS 4586, BCRA. Como puede intuirse, se trata de una primera contribución para la orientación en la selección y no de una garantía específica; la empresa está a disposición para hacer comprobar, a petición y en laboratorios oficiales, lotes individuales del material prese-leccionado según el método de prueba indicado por el usuario.

La nuova gamma di linee di pavimento in gres, ceramica e porcellana, è composta da 12 collezioni, di cui 6 in gres e 6 in ceramica.
Le nuove linee di pavimento in gres, ceramica e porcellana, sono composte da 12 collezioni, di cui 6 in gres e 6 in ceramica.

La nuova gamma di linee di pavimento in gres, ceramica e porcellana, è composta da 12 collezioni, di cui 6 in gres e 6 in ceramica.
Le nuove linee di pavimento in gres, ceramica e porcellana, sono composte da 12 collezioni, di cui 6 in gres e 6 in ceramica.

### DIN EN 16165 ANNEX A





Flooring of work environments and operating areas with slippery surfaces

Pavimentazioni di ambienti e zone operative con superfici sdrucciolevoli

Sols de milieux industriels et de zones de travail à surfaces glissantes

Böden für Arbeitsräume und Arbeitszonen mit rutschiger Oberfläche

Pavimentaciones de zonas de trabajo y operativas con superficies resbaladizas

Risk of slipping <p>Gruppo di qualificazione</p> Risque de glisser Rutschgefahr Riesgo de deslizamiento	Angle of slope <p>Angolo d’inclinazione</p> Angle d’inclinaison Neigungswinkel Ángulo de inclinación	
<b>R9</b>	<b>da 6° from / de mehr als / de</b>	
<b>R10</b>	<b>oltre 10° from / au-delà de mehr als / más de</b>	
<b>R11</b>	<b>oltre 19° from / au-delà de mehr als / más de</b>	
<b>R12</b>	<b>oltre 27° from / au-delà de mehr als / más de</b>	
<b>R13</b>	<b>oltre 35° from / au-delà de mehr als / más de</b>	

PENDULUM - AUSTRALIAN		PENDULUM - ENGLISH	
Class AS 4586	Pendulum SRV Slider 55	Indicative Values BS EN 16165 ANNEX C	SLIP POTENTIAL
P5	> 44	0-25	High
P4	<b>40 - 44</b>	26-35	Moderate
P3	<b>35 - 39</b>	36-65	Low
P2	<b>20 - 34</b>	> 65	Extremely low
P1	< 20		

## Index by slip characteristics - Indice per caratteristiche di resistenza allo scivolamento

Index par caractéristiques antidérapantes - Inhaltsverzeichnis für die Antirutschigenschaften - Índice para características antislip

		<b>Shot Ramp Test</b> <b>Metodo della rampa “calzato”</b> <b>DIN EN 16165 ANNEX B</b>				<b>Barefood Ramp Test</b> <b>Metodo della rampa a piedi nudi</b> <b>DIN EN 16165 ANNEX A</b>			<b>Dynamic coefficient of friction COF</b> <b>Coefficiente di attrito dinamico DCOF</b> <b>ANSI A326.3 – 2012</b>	<b>BS EN 16165 ANNEX C</b> <b>PTV ≥ 36</b> <b>“Lon Sup Risk”</b>	<b>AS 4586</b>
<b>Series</b> Serie/Série Serie/Serie	<b>Surface</b> Superficie/Surface Oberfläche/Superficie	<b>R9</b>	<b>R10</b>	<b>R11</b>	<b>R13</b>	<b>A</b>	<b>A+B</b>	<b>A+B+C</b>	<b>&gt;0,42 wet</b>		
<b>Archè</b>	<b>Natural / Naturale</b>		■				■ mos		■		
	<b>Grip / Grip</b>			■				■	■	≥ 36 Dry / ≥ 36 Wet	Class P4
<b>Azimuth</b>	<b>Natural / Naturale</b>		■				■ mos		■		
	<b>Brushed / Molata</b>										
	<b>Grip / Grip</b>			■				■	■	≥ 36 Dry / ≥ 36 Wet	Class P4
<b>On Stage</b>	<b>Natural / Naturale</b>		■				■ mos		■		
	<b>Brushed / Molata</b>								■		
<b>Ashley</b>	<b>Natural / Naturale</b>		■					mos	■		
	<b>Grip / Grip</b>			■				■	■	≥ 36 Dry / ≥ 36 Wet	Class P4
<b>Esprit</b>	<b>Natural / Naturale</b>		■				■		■	≥ 36 Dry / ≥ 36 Wet	Class P3
<b>Pietra Castello</b>	<b>Natural / Naturale</b>	■					mos		■		
	<b>Grip / Grip</b>			■				■	■	≥ 36 Dry / ≥ 36 Wet	Class P4
<b>Woodtime</b>	<b>Natural / Naturale</b>		■			■		mos	■		
	<b>Grip / Grip</b>			■				■	■	≥ 36 Dry / ≥ 36 Wet	Class P4
<b>Yukon</b>	<b>Natural / Naturale</b>		■				■	mos	■		
<b>Transalp</b>	<b>Glossy polished /</b> <b>Levigata a specchio</b>										
<b>Charisma</b>	<b>Natural / Naturale</b>	■					mos		■		
	<b>Lapped / Lappata</b>								■		
	<b>Grip / Grip</b>			■				■	■	≥ 36 Dry / ≥ 36 Wet	Class P4
<b>Evolution</b>	<b>Natural / Naturale</b>		■						■		
	<b>Lapped / Lappata</b>								■		
<b>Dolomite</b>	<b>Natural / Naturale</b>		■				■ mos	mos	■		
	<b>Grip / Grip</b>			■				■	■	≥ 36 Dry / ≥ 36 Wet	Class P4
<b>Geobrick</b>	<b>Grip / Grip</b>			■				■	■	≥ 36 Dry / ≥ 36 Wet	Class P4
	<b>Natural / Naturale</b>		■						■		
<b>Pietre Naturali</b>	<b>Natural / Naturale</b>		■				mos	mos	■		
	<b>Grip / Grip</b>			■				■	■	≥ 36 Dry / ≥ 36 Wet	Class P4
	<b>Lappata / Lapped</b>										
<b>Tradition</b>	<b>Natural / Naturale</b>		■				mos	mos	■		
	<b>Grip / Grip</b>			■				■	■	≥ 36 Dry / ≥ 36 Wet	Class P4
	<b>Lappata / Lapped</b>										
<b>Blade</b>	<b>Natural / Naturale</b>		■				mos		■		
	<b>Grip / Grip</b>			■				■	■	≥ 36 Dry / ≥ 36 Wet	Class P4
<b>Graphis</b>	<b>Natural / Naturale</b>		■				mos	mos	■		
	<b>Grip / Grip</b>			■				■	■	≥ 36 Dry / ≥ 36 Wet	Class P4
<b>Dicta</b>	<b>Natural / Naturale</b>		■				■ mos		■		
	<b>Grip / Grip</b>			■				■	■		
<b>Gamut</b>	<b>Natural / Naturale</b>		■				■ mos		■		Class P3
	<b>Nat Dec.</b>	■									
	<b>Soft / Soft</b>	■									

# Index

The Company

Technology

Sizes

Thicknesses

Surfaces

Porcelain stoneware

Ecologycare

Certifications

Quality and Safety

Ceramic of Italy

Fincibec Group

Campus

Engineering

Pools & Wellness

Facades

Raised Flooring

**Technical Specifications**

## Contents by collection

Archè	Geobrick
Ashley	Graphis
Azimuth	On Stage
Blade	Pietra Castello
Charisma	Pietre Naturali
Dicta	Tradition
Dolomite	Transalp
Esprit	Woodtime
Evolution	Yukon
Gamut	Major

## Contents by effect

WOOD - Legno

MARBLE - Marmo

STONE - Pietra

CONCRETE - Cemento

## Color Index

Color Index Major 20mm

★★★★★  
**MONOCIBEC**<sup>®</sup>  
FINCIBEC GROUP



**Warnings. Avvertenza.**  
Attention - Hinweis - Advertencia

Porcelain stoneware slab with a polished finish

Polished surface porcelain stoneware slab

Polished surface porcelain stoneware slab

**7 MM PORCELAIN STONEWARE SLABS FOR FLOORS - LASTRE IN GRES PORCELLANATO 7 MM IMPIEGO A PAVIMENTO**

DALLES EN GRÈS CÉRAME 7 MM POUR LE SOL - FEINSTEINZEUGFLIESEN 7 MM VERWENDUNG ALS BODENBELAG - PLACAS DE GRES PORCELÁNICO DE 7 MM PARA USO EN SUELOS

Porcelain stoneware slab

The Fincibec Group’s 7 mm porcelain stoneware slabs are innovative high performance solutions for floors and walls in homes and in commercial premises with a low footfall. Given their limited thickness, 7 mm format slabs are not suitable for floors in locations with flows of heavy, concentrated loads or the circulation of forklift trucks. Before laying a floor with 7 mm slabs, a perfectly level and completely stabilised screed is necessary. The slabs must be laid by expert professionals, creating the required expansion joints and applying the adhesive with the “double spreading” technique, which optimises the distribution of the product and avoids empty spaces that could cause cracking. During restructuring work, the weight of 7 mm ceramic slabs means they can be laid without having to remove and dispose of existing floor and wall coverings. This type of application depends on the condition of the underlying surface, which, whatever the material (ceramic, marble or other natural stones), must be free of cracks, perfectly level and stable. It is essential to call in an expert designer to assess the use of 7 mm slabs for floors. When the underlying surface presents irreversible stability problems or the screed has not been correctly laid, they should be restored before the slabs are laid.

Porcelain stoneware slab

Porcelain stoneware slab

Les dalles du Groupe Fincibec en grès cérame épaisseur 7 mm sont des solutions innovantes et performantes pour la réalisation de sols et de revêtements en milieu résidentiel et dans les locaux commerciaux soumis à un trafic léger. En raison de leur épaisseur réduite, il faut éviter de poser au sol des grandes dalles 7 mm sur les lieux prévoyant le passage de charges lourdes et concentrées ou le passage de chariots. Avant de réaliser un sol avec un revêtement en dalles de 7 mm, il est nécessaire de prévoir un support parfaitement plat et parfaitement sec. La pose des dalles doit être confiée à des techniciens spécialisés qui doivent respecter les joints de dilatation prévus et appliquer l’adhésif selon la technique du double-encollage qui optimise la distribution du produit et évite de laisser des espaces vides susceptibles de ruptures. Pendant la phase de restructuration, le poids des surfaces céramiques 7 mm permet la pose sur les sols et revêtements préexistants, sans devoir auparavant démolir et éliminer le matériau existant. Ce type d’utilisation est étroitement lié aux conditions du support qui, indépendamment du matériau (céramique, marbre ou autres pierres naturelles), ne doit présenter aucune trace de fissures et doit être parfaitement plat et stable. Il est indispensable de recourir à un concepteur expert qui se chargera d’évaluer la possibilité d’utiliser ou non sur le sol les solutions 7 mm. Si le support présente des problèmes irréversibles de stabilité ou d’enduit non réalisé selon les règles de l’art, nous recommandons de remettre le support en bon état avant de procéder à la pose.

Porcelain stoneware slab

Polished surface porcelain stoneware slab

Polished surface porcelain stoneware slab

Polished surface porcelain stoneware slab

Polished surface porcelain stoneware slab

Polished surface porcelain stoneware slab

Polished surface porcelain stoneware slab

Polished surface porcelain stoneware slab

Polished surface porcelain stoneware slab

Porcelain stoneware slab

Polished surface porcelain stoneware slab

Polished surface porcelain stoneware slab

Polished surface porcelain stoneware slab

Polished surface porcelain stoneware slab

Polished surface porcelain stoneware slab

Le lastre Fincibec Group in gres porcellanato con spessore 7 mm sono soluzioni innovative e performanti per la realizzazione di pavimenti e rivestimenti in ambito residenziale e negli spazi commerciali a traffico leggero. Per le caratteristiche legate allo spessore contenuto, la posa a pavimento dei grandi formati 7 mm è da evitare nelle situazioni in cui sia previsto il passaggio di carichi pesanti e concentrati o, comunque, il transito di carrelli. Prima di realizzare una pavimentazione con lastre 7 mm è indispensabile predisporre un massetto perfettamente planare e completamente stagionato. La posa delle lastre deve essere effettuata da professionisti esperti, rispettando i giunti di dilatazione previsti e applicando l’adesivo secondo la tecnica cosiddetta “della doppia spalmatura” che ottimizza la distribuzione del prodotto ed evita che vengano lasciati spazi vuoti, potenziale causa di rotture. In fase di ristrutturazione, il peso delle superfici ceramiche 7 mm permette la posa sulle pavimentazioni e sui rivestimenti preesistenti, senza procedere preventivamente alla demolizione e allo smaltimento. Questa tipologia di impiego è strettamente legata alle condizioni del sottofondo che, indipendentemente dal materiale (ceramica, marmo o altre pietre naturali), deve risultare privo di fessurazioni, perfettamente planare e stabile. Il coinvolgimento di un progettista esperto è indispensabile per valutare l’effettivo impiego a pavimento delle soluzioni 7 mm. In caso di sottofondo con problemi irreversibili di stabilità o di massetto realizzato non a regola d’arte, si consiglia il ripristino degli stessi prima di procedere con la posa.

Porcelain stoneware slab

Polished surface porcelain stoneware slab

Polished surface porcelain stoneware slab

Polished surface porcelain stoneware slab

Polished surface porcelain stoneware slab

Polished surface porcelain stoneware slab

Polished surface porcelain stoneware slab

Polished surface porcelain stoneware slab

Polished surface porcelain stoneware slab

Polished surface porcelain stoneware slab

Polished surface porcelain stoneware slab

Polished surface porcelain stoneware slab

Polished surface porcelain stoneware slab

Polished surface porcelain stoneware slab

Polished surface porcelain stoneware slab

Polished surface porcelain stoneware slab

Polished surface porcelain stoneware slab

Polished surface porcelain stoneware slab

Polished surface porcelain stoneware slab

Polished surface porcelain stoneware slab

Polished surface porcelain stoneware slab

Polished surface porcelain stoneware slab

Polished surface porcelain stoneware slab

Porcelain stoneware slab

Polished surface porcelain stoneware slab

Polished surface porcelain stoneware slab

Polished surface porcelain stoneware slab

Polished surface porcelain stoneware slab

Polished surface porcelain stoneware slab

Polished surface porcelain stoneware slab

Polished surface porcelain stoneware slab

Polished surface porcelain stoneware slab

Polished surface porcelain stoneware slab

Polished surface porcelain stoneware slab

Polished surface porcelain stoneware slab

Polished surface porcelain stoneware slab

Polished surface porcelain stoneware slab

Polished surface porcelain stoneware slab

Polished surface porcelain stoneware slab

Polished surface porcelain stoneware slab

Polished surface porcelain stoneware slab

Polished surface porcelain stoneware slab

Polished surface porcelain stoneware slab

Polished surface porcelain stoneware slab

Polished surface porcelain stoneware slab

Polished surface porcelain stoneware slab

Polished surface porcelain stoneware slab

Polished surface porcelain stoneware slab

Polished surface porcelain stoneware slab

Polished surface porcelain stoneware slab

Polished surface porcelain stoneware slab

Polished surface porcelain stoneware slab

Polished surface porcelain stoneware slab

Polished surface porcelain stoneware slab

Polished surface porcelain stoneware slab

Polished surface porcelain stoneware slab

Polished surface porcelain stoneware slab

Polished surface porcelain stoneware slab

Polished surface porcelain stoneware slab

Polished surface porcelain stoneware slab

Polished surface porcelain stoneware slab

Polished surface porcelain stoneware slab

Polished surface porcelain stoneware slab

Porcelain stoneware slab

Polished surface porcelain stoneware slab

Polished surface porcelain stoneware slab

Polished surface porcelain stoneware slab

Polished surface porcelain stoneware slab

Polished surface porcelain stoneware slab

Polished surface porcelain stoneware slab

Polished surface porcelain stoneware slab

Polished surface porcelain stoneware slab

Polished surface porcelain stoneware slab

Polished surface porcelain stoneware slab

Polished surface porcelain stoneware slab

Polished surface porcelain stoneware slab

Polished surface porcelain stoneware slab

Polished surface porcelain stoneware slab

Polished surface porcelain stoneware slab

Polished surface porcelain stoneware slab

Polished surface porcelain stoneware slab

Polished surface porcelain stoneware slab

Polished surface porcelain stoneware slab

Polished surface porcelain stoneware slab

Polished surface porcelain stoneware slab

Polished surface porcelain stoneware slab

Polished surface porcelain stoneware slab

Polished surface porcelain stoneware slab

Polished surface porcelain stoneware slab

Polished surface porcelain stoneware slab

Polished surface porcelain stoneware slab

Polished surface porcelain stoneware slab

Polished surface porcelain stoneware slab

Polished surface porcelain stoneware slab

Polished surface porcelain stoneware slab

Polished surface porcelain stoneware slab

Polished surface porcelain stoneware slab

Polished surface porcelain stoneware slab

Polished surface porcelain stoneware slab

Polished surface porcelain stoneware slab

Polished surface porcelain stoneware slab

Polished surface porcelain stoneware slab

Polished surface porcelain stoneware slab

# Index

The Company

Technology

Sizes

Thicknesses

Surfaces

Porcelain stoneware

Ecologycare

Certifications

Quality and Safety

Ceramic of Italy

Fincibec Group

Campus

Engineering

Pools &amp; Wellness

Facades

Raised Flooring

Technical Specifications
--------------------------

Porcelain stoneware slab

Polished surface porcelain stoneware slab

Polished surface porcelain stoneware slab

Polished surface porcelain stoneware slab

Polished surface porcelain stoneware slab

Polished surface porcelain stoneware slab

Polished surface porcelain stoneware slab

Polished surface porcelain stoneware slab

Polished surface porcelain stoneware slab

Polished surface porcelain stoneware slab

Polished surface porcelain stoneware slab

Polished surface porcelain stoneware slab

Polished surface porcelain stoneware slab

Polished surface porcelain stoneware slab

Polished surface porcelain stoneware slab

Polished surface porcelain stoneware slab

Polished surface porcelain stoneware slab

Polished surface porcelain stoneware slab

Polished surface porcelain stoneware slab

Polished surface porcelain stoneware slab

Polished surface porcelain stoneware slab

Polished surface porcelain stoneware slab

Polished surface porcelain stoneware slab

Polished surface porcelain stoneware slab

Polished surface porcelain stoneware slab

Polished surface porcelain stoneware slab

Polished surface porcelain stoneware slab

Polished surface porcelain stoneware slab

Polished surface porcelain stoneware slab

Polished surface porcelain stoneware slab

Polished surface porcelain stoneware slab

Polished surface porcelain stoneware slab

Polished surface porcelain stoneware slab

Polished surface porcelain stoneware slab

Polished surface porcelain stoneware slab

Polished surface porcelain stoneware slab

Polished surface porcelain stoneware slab

Polished surface porcelain stoneware slab

Polished surface porcelain stoneware slab

Polished surface porcelain stoneware slab

Polished surface porcelain stoneware slab

Polished surface porcelain stoneware slab

Polished surface porcelain stoneware slab

Polished surface porcelain stoneware slab

Polished surface porcelain stoneware slab

Polished surface porcelain stoneware slab

Polished surface porcelain stoneware slab

Polished surface porcelain stoneware slab

Polished surface porcelain stoneware slab

Polished surface porcelain stoneware slab

Polished surface porcelain stoneware slab

Polished surface porcelain stoneware slab

Polished surface porcelain stoneware slab

Polished surface porcelain stoneware slab

Polished surface porcelain stoneware slab

Polished surface porcelain stoneware slab

Polished surface porcelain stoneware slab

Polished surface porcelain stoneware slab

Polished surface porcelain stoneware slab

Polished surface porcelain stoneware slab

Polished surface porcelain stoneware slab

Polished surface porcelain stoneware slab

Polished surface porcelain stoneware slab

Polished surface porcelain stoneware slab

Polished surface porcelain stoneware slab

Polished surface porcelain stoneware slab

Polished surface porcelain stoneware slab

Polished surface porcelain stoneware slab

Polished surface porcelain stoneware slab

Polished surface porcelain stoneware slab

Polished surface porcelain stoneware slab

Polished surface porcelain stoneware slab

Polished surface porcelain stoneware slab

Polished surface porcelain stoneware slab

Polished surface porcelain stoneware slab

Polished surface porcelain stoneware slab

Polished surface porcelain stoneware slab

Polished surface porcelain stoneware slab

Polished surface porcelain stoneware slab

Polished surface porcelain stoneware slab

Polished surface porcelain stoneware slab

Polished surface porcelain stoneware slab

Polished surface porcelain stoneware slab

Polished surface porcelain stoneware slab

Polished surface porcelain stoneware slab

Polished surface porcelain stoneware slab

Polished surface porcelain stoneware slab

Polished surface porcelain stoneware slab

Polished surface porcelain stoneware slab

Polished surface porcelain stoneware slab

Polished surface porcelain stoneware slab

Polished surface porcelain stoneware slab

Polished surface porcelain stoneware slab

Polished surface porcelain stoneware slab

Polished surface porcelain stoneware slab

Polished surface porcelain stoneware slab

Polished surface porcelain stoneware slab

Polished surface porcelain stoneware slab

Polished surface porcelain stoneware slab

Polished surface porcelain stoneware slab

Polished surface porcelain stoneware slab

Polished surface porcelain stoneware slab

Polished surface porcelain stoneware slab

Polished surface porcelain stoneware slab

Polished surface porcelain stoneware slab

Polished surface porcelain stoneware slab

Polished surface porcelain stoneware slab

Polished surface porcelain stoneware slab

Polished surface porcelain stoneware slab

Polished surface porcelain stoneware slab

Polished surface porcelain stoneware slab

Polished surface porcelain stoneware slab

Polished surface porcelain stoneware slab

Polished surface porcelain stoneware slab

Polished surface porcelain stoneware slab

Polished surface porcelain stoneware slab

Polished surface porcelain stoneware slab

Polished surface porcelain stoneware slab

Polished surface porcelain stoneware slab

Polished surface porcelain stoneware slab

Polished surface porcelain stoneware slab

Polished surface porcelain stoneware slab

Polished surface porcelain stoneware slab

Polished surface porcelain stoneware slab

Polished surface porcelain stoneware slab

Polished surface porcelain stoneware slab

Polished surface porcelain stoneware slab

Polished surface porcelain stoneware slab

Polished surface porcelain stoneware slab



















Polished surface porcelain stoneware slab

Polished surface porcelain stoneware slab

Polished surface porcelain stoneware slab

Polished surface porcelain stoneware slab
&lt;/

**STANDARDS : UNI EN 14411 ANNEX G - Bla / UNI EN ISO 13006 ANNEX G - Bla**

CARATTERISTICHE TECNICHE TECHNICAL DATA TECHNISCHE DATEN CARACTERÍSTICAS TÉCNICAS CARACTERÍSTICAS TÉCNICAS ТЕХНИЧЕСКИЕ ХАРАКТЕРИСТИКИ		TIPO DI PROVA STANDARD OF TEST NORME DU TEST TESTNORM TIPO DE PRUEBA TIPO TESTA	VALORI PRESCRITTI DALLE NORME INTERNATIONAL STANDARDS INTERNATIONALE NORMWERTE VALEURS PREVUES PAR LES NORMES VALORES PREVISTOS POR LAS NORMAS ПРЕДСМОТРЕННЫЕ СТАНДАРТОМ			VALORE MEDIO MONOCIBEC MONOCIBEC AVERAGE VALUE MONOCIBEC MITTELWERT VALEUR MOYENNE MONOCIBEC VALOR MEDIO MONOCIBEC СРЕДНЕЕ ЗНАЧЕНИЕ MONOCIBEC
CARATTERISTICHE DIMENSIONALI - SIZE CHARACTERISTICS - MASSEIGENSCHAFTEN - DETERMINATION DES CARACTERISTIQUES DIMENSIONELLES CARACTERÍSTICAS DIMENSIONALES - РАЗМЕРНЫЕ ХАРАКТЕРИСТИКИ			REQUIREMENTS FOR NOMINAL SIZE N			
			7 cm ≤ N < 15 cm	N ≥ 15 cm		
			mm	%	mm	
	LATI SIDES - SEITEN COTES - CANTOS РАЗМЕРЫ СТОРОН	FOR NON-RECTIFIED TILES	±0.9	±0.6	±2.0	CONFORME COMPLYING - ERFÜLLT CONFORME - CONFORME COOBTETCTBYET
		FOR RECTIFIED TILES	±0.4	±0.3	±1.0	
	SPESORE THICKNESS - DICKE ÉPAISSEUR - ESPESOR ТОЛЩИНА		±0.5	±5.0	±0.5	CONFORME COMPLYING - ERFÜLLT CONFORME - CONFORME COOBTETCTBYET
	RETTILINEITÀ DEGLI SPIGOLI STRAIGHTNESS OF SIDES - GERADLINIGKEIT DER KANTEN RECTITUDE DES ARÊTES - RECTITUD DE LOS CANTOS - КОСОУГОЛЬНОСТЬ	FOR NON-RECTIFIED TILES	±0.8	±0.5	±1.5	CONFORME COMPLYING - ERFÜLLT CONFORME - CONFORME COOBTETCTBYET
		FOR RECTIFIED TILES	±0.4	±0.3	±0.8	
	ORTOGONALITÀ RECTANGULARITY - RECHTWINKLIGKEIT PERPENDICULARITÉ - ORTOGONALIDAD КРЯВИЗНА СТОРОН	FOR NON-RECTIFIED TILES	±0.8	±0.5	±2.0	CONFORME COMPLYING - ERFÜLLT CONFORME - CONFORME COOBTETCTBYET
		FOR RECTIFIED TILES	±0.4	±0.3	±1.5	
	PLANARITÀ SURFACE FLATNESS - EBENFLÄCHIGKEIT PLANEITE DE SURFACE - PLANEIDAD КРЯВИЗНА ЛИЦЕВОЙ ПОВЕРХНОСТИ	CENTRE CURVATURE FOR NON-RECTIFIED TILES	±0.8	±0.5	±2.0	CONFORME COMPLYING - ERFÜLLT CONFORME - CONFORME COOBTETCTBYET
		FOR RECTIFIED TILES	±0.6	±0.4	±1.8	
		EDGE CURVATURE FOR NON-RECTIFIED TILES	±0.8	±0.5	±2.0	
		FOR RECTIFIED TILES	±0.6	±0.4	±1.8	
	WARPAGE FOR NON-RECTIFIED TILES		±0.8	±0.5	±2.0	
		FOR RECTIFIED TILES	±0.6	±0.4	±1.8	
	ASSORBIMENTO D'ACQUA WATER ABSORPTION - WASSERAUFNAHME ABSORPTION D'EAU - ABSORCIÓN DE AGUA ВОДОПОГЛОЩЕНИЕ		≤ 0.5%		≤ 0.1%	
	RESISTENZA ALLA FLESSIONE FLEXION RESISTANCE - BIEGEFESTIGKEIT RESISTANCE A LA FLEXION - RESISTENCIA A LA FLEXIÓN ПРЕДЕЛ ПРОЧНОСТИ ПРИ ИЗГИБЕ		S ≥ 700 N $\downarrow$ < 7,5 mm		CONFORME COMPLYING - ERFÜLLT CONFORME - CONFORME COOBTETCTBYET	
			S ≥ 1.300 N $\downarrow$ ≥ 7,5 mm			
			R ≥ 35 N/mm			
	RESISTENZA ALL'URTO IMPACT RESISTANCE - STOSSFESTIGKEIT RESISTANCE AUX CHOCS - RESISTENCIA A LOS GOLPES УДАРНОСТОЙКОСТЬ		VALORE DICHIARATO DECLARED VALUE - ANGEGBENER WERT VALEUR DÉCLARÉE - VALOR DECLARADO - ЗАЯВЛЕННОЕ ЗНАЧЕНИЕ		> 0,80	
	COEFFICIENTE DI DILATAZIONE TERMICA LINEARE COEFFICIENT OF LINEAR THERMAL EXPANSION - LINEARER WÄRMEAUSENDENUNGSKOEFFIZIENT COEFFICIENT DE DILATION THERMIQUE LINEARE - COEFICIENTE DE DILACIÓN TERMICA LINEAL КОЭФФИЦИЕНТ ЛИНЕЙНОГО ТЕРМИЧЕСКОГО РАСШИРЕНИЯ		VALORE DICHIARATO DECLARED VALUE - ANGEGBENER WERT VALEUR DÉCLARÉE - VALOR DECLARADO - ЗАЯВЛЕННОЕ ЗНАЧЕНИЕ		α = 6,7x10 <sup>-6</sup> /C°	
	RESISTENZA AGLI SBALZI TERMICI RESISTANCE TO THERMAL SHOCKS - BESTÄNDIGKEIT GEGEN TEMPERATURSCHWANKUNGEN RESISTANCE AUX CHocs THERMIQUES - RESISTENCIA A LOS CHOQUES TÉRMICOS СТОЙКОСТЬ К ПЕРЕПАДАМ ТЕМПЕРАТУРЫ		TEST SUPERATO SECONDO EN ISO 10545-1 TEST PASSED ACCORDING TO - TEST BESTANDEN NACH TEXTE DÉPASSÉ SELON - PRUEBA SUPERADA SEGUN ИСПЫТАНИЕ ПРОЙДЕНО В СООТВЕТСТВИИ С		NESSUN DANNO NO DAMAGE - KEIN SCHADEN AUCUN DOMMAGE -NINGUN DANO БЕЗ ПОВРЕЖДЕНИЙ	
	DILATAZIONE ALL'UMIDITÀ (IN MMM) MOISTURE EXPANSION (IN MMM) - FEUCHTIGKEITSBEDINGTE AUSDEHNUNG (IN MMM) DILATION À L'HUMIDITÉ (EN MMM) - DILACIÓN CON LA HUMEDAD (EN MMM) ВЛАЖНОСТНОЕ РАСШИРЕНИЕ (В MMM)		VALORE DICHIARATO DECLARED VALUE - ANGEGBENER WERT VALEUR DÉCLARÉE - VALOR DECLARADO - ЗАЯВЛЕННОЕ ЗНАЧЕНИЕ		MAX 0,1 mm / m	
	RESISTENZA AL GELO FROST RESISTANCE - FROSTBESTÄNDIGKEIT RESISTANCE AU GEL - RESISTENCIA AL HIELO МОРОЗОСТОЙКОСТЬ		TEST SUPERATO SECONDO EN ISO 10545-1 TEST PASSED ACCORDING TO - TEST BESTANDEN NACH TEXTE DÉPASSÉ SELON - PRUEBA SUPERADA SEGUN ИСПЫТАНИЕ ПРОЙДЕНО В СООТВЕТСТВИИ С		NESSUN DANNO NO DAMAGE - KEIN SCHADEN AUCUN DOMMAGE -NINGUN DANO БЕЗ ПОВРЕЖДЕНИЙ	
	RESISTENZA AI PRODOTTI CHIMICI USO DOMESTICO E ADDITIVI PER PISCINA RESISTANCE TO HOUSEHOLD AND SWIMMING POOL CHEMICAL PRODUCTS - RBESTÄNDIGKEIT GEGEN HAUSHALTSCHENIKALIEN UND ZUSATZSTOFFE FÜR SWIMMINGPOOLS - RESISTANCE AUX PRODUITS CHIMIQUES USAGE DOMESTIQUE ET ADDITIFS POUR PISCINE - RESISTENCIA A LOS PRODUCTOS QUÍMICOS DE USO DOMÉSTICO Y ADITIVOS PARA PISCINA - СТОЙКОСТЬ К ДЕЙСТВИЮ БЫТОВЫХ ХИМИЧЕСКИХ СРЕДСТВ, ДОБАВКАМ В БАССЕЙНЫ		B MIN		CONFORME COMPLYING - ERFÜLLT CONFORME - CONFORME COOBTETCTBYET	
	RESISTENZA A BASSE CONCENTRAZIONI DI ACIDI E ALCALI RESISTANCE TO LOW CONCENTRATIONS OF ACIDS AND ALKALI - BESTÄNDIGKEIT BEI NIEDRIGEN KONZENTRATIONEN VON SÄUREN UND LAUGEN - RESISTANCE À BASSES CONCENTRATIONS D'ACIDES ET ALCALIS - RESISTENCIA A BAJAS CONCENTRACIONES DE ÁCIDOS Y ALCALIS - СТОЙКОСТЬ К ДЕЙСТВИЮ НИЗКИХ КОНЦЕНТРАЦИЙ КИСЛОТ И ЩЕЛОЧЕЙ		VALORE DICHIARATO DECLARED VALUE - ANGEGBENER WERT VALEUR DÉCLARÉE - VALOR DECLARADO - ЗАЯВЛЕННОЕ ЗНАЧЕНИЕ		CONFORME COMPLYING - ERFÜLLT CONFORME - CONFORME COOBTETCTBYET	
	RESISTENZA AD ALTE CONCENTRAZIONI DI ACIDI E ALCALI RESISTANCE TO HIGH CONCENTRATIONS OF ACIDS AND ALKALI - BESTÄNDIGKEIT BEI HOHEN KONZENTRATIONEN VON SÄUREN UND LAUGEN - RESISTANCE À HAUTES CONCENTRATIONS D'ACIDES ET ALCALIS - RESISTENCIA A ALTAS CONCENTRACIONES DE ÁCIDOS Y ALCALIS - СТОЙКОСТЬ К ДЕЙСТВИЮ ВЫСОКИХ КОНЦЕНТРАЦИЙ КИСЛОТ И ЩЕЛОЧЕЙ		VALORE DICHIARATO DECLARED VALUE - ANGEGBENER WERT VALEUR DÉCLARÉE - VALOR DECLARADO - ЗАЯВЛЕННОЕ ЗНАЧЕНИЕ		CONFORME COMPLYING - ERFÜLLT CONFORME - CONFORME COOBTETCTBYET	
	RESISTENZA ALLE MACCHIE RESISTANCE TO STAINS - FLECKENBESTÄNDIGKEIT RESISTANCE AUX TACHES - RESISTENCIA A LAS MANCHAS УСТОЙЧИВОСТЬ К ПЯТНООБРАЗОВАНИЮ		CLASSE 3 MIN		CONFORME COMPLYING - ERFÜLLT CONFORME - CONFORME COOBTETCTBYET	
	CESSIONE DI PIOMBO E CADMIO LEAD AND CADMIUM DISCHARGE - ABGABE VON BLEI UND CADMIUM PERTE DE PLOMB ET CADMIUM - CESIÓN DE PLOMO Y CADMIO ВЫДЕЛЕНИЕ СВИНЦА И КАДИМИЯ		VALORE DICHIARATO DECLARED VALUE - ANGEGBENER WERT VALEUR DÉCLARÉE - VALOR DECLARADO - ЗАЯВЛЕННОЕ ЗНАЧЕНИЕ		< AL LIMITE DI RILEVAMENTO < THAN INSTRUMENT LIMIT < UNMESSBARES WERT < LIMITE DE L'INSTRUMENT - LIMITE DEL INSTRUMENTO < НА ПРЕДЕЛЕ ОПРЕДЕЛИМОСТИ	

**FOR SPECIFIC CERTIFICATES AND DATA, CONTACT FINCIBEC S.P.A - PER I CERTIFICATI SPECIFICI, E VALORI PUNTUALI, CONTATTARE FINCIBEC SPA - FÜR SPEZIELLE ZERTIFIKATE UND PUNKTWERTE, FINCIBEC S.P.A. KONTAKTIEREN - POUR LES CERTIFICATS SPÉCIFIQUES ET LES VALEURS PONCTUELLES, CONTACTER FINCIBEC S.P.A - PARA LOS CERTIFICADOS ESPECÍFICOS Y LOS VALORES CONCRETOS, CONTACTE CON FINCIBEC S.P.A - ВО ВОПРОСАМ СПЕЦИАЛЬНЫХ СЕРТИФИКАТОВ И ПОКАЗАТЕЛЕЙ СВЯЖИТЕСЬ С FINCIBEC SPA.**

FULLY-RESISTANT FLOORING on fine porcelain stoneware, ISO 13006 Bla  
 PAVIMENTI A RESISTENZA TOTALE su gres fine porcellanato ISO 13006 Bla  
 SOLS À RESISTANCE TOTALE SUR le grès cérame fin, ISO 13006 Bla - ABSOLUT WIDERSTÄNDIGE Feinsteinzeug-Fußböden ISO 13006 Bla  
 PAVIMENTOS DE RESISTENCIA TOTAL de gres fino porcelánico ISO 13006 Bla

The “gres fine porcellanato” logo represents “Monocibec” floor tiles; an ideal product for satisfying all professional requirements in terms of residential and public commercial building.

Il marchio di fabbrica “gres fine porcellanato”, contrassegna le piastrelle da pavimento “Monocibec” destinate ad utilizzi tecnici interni ed esterni che richiedono particolari specifiche normative da parte del progettista.

La marque de fabrique “gres fine porcellanato”, caractérise les carreaux de sol “Monocibec”, destinés à des applications techniques, à l’intérieur ou à l’extérieur, qui exigent le respect de réglementations spécifiques de la part du concepteur.

Das Warenzeichen “gres fine porcellanato”, kennzeichnet “Monocibec” bodenfiesen. Diese Fliesen sind für Außen- und Innenbereiche geeignet. Auch sind sie für technische Anwendungen im Innen- und Außenbereich bestimmt, bei denen der Planer besondere Vorschriften zu beachten hat.

La marca de fábrica “gres fine porcellanato” identifica los azulejos para suelos “Monocibec” realizados para usos técnicos en interiores y exteriores con unas características normativas específicas exigidas por el diseñador.



**Fincibec Spa, Via Valle d’Aosta 47  
 41049 Sassuolo (MO)-ITALY  
 05  
 001FINCIBEC**

**EN 14411  
 Dry-pressed ceramic tiles, with water  
 absorption Eb ≤ 0,5%, for internal and external  
 walls and floorings**



For information, relevant to CE marking, visit the web site: | Per i dati relativi alla marcatura CE visitare il sito:  
 Pour les données concernant le marquage CE, visitez le site: | Weitere Informationen zur “markierung CE” entnehmen sie bitte der website: | Para los datos relativos al marcado CE, visite el sitio:

# Index

- The Company
- Technology
- Sizes
- Thicknesses
- Surfaces
- Porcelain stoneware
- Ecologycare
- Certifications
- Quality and Safety
- Ceramic of Italy
- Fincibec Group
- Campus
- Engineering
- Pools & Wellness
- Facades
- Raised Flooring
- Technical Specifications**

## Contents by collection

- Archè
- Ashley
- Azimuth
- Blade
- Charisma
- Dicta
- Dolomite
- Esprit
- Evolution
- Gamut
- Geobrick
- Graphis
- On Stage
- Pietra Castello
- Pietre Naturali
- Tradition
- Transalp
- Woodtime
- Yukon
- Major

## Contents by effect

- WOOD - Legno
- MARBLE - Marmo
- STONE - Pietra
- CONCRETE - Cemento

## Color Index

Color Index Major 20mm



# Index

The Company  
Technology  
Sizes  
Thicknesses  
Surfaces  
Porcelain stoneware  
Ecologycare  
Certifications  
Quality and Safety  
Ceramic of Italy  
Fincibec Group  
Campus  
Engineering  
Pools & Wellness  
Facades  
Raised Flooring

**Technical Specifications**

## > Contents by collection

Archè	Geobrick
Ashley	Graphis
Azimuth	On Stage
Blade	Pietra Castello
Charisma	Pietre Naturali
Dicta	Tradition
Dolomite	Transalp
Esprit	Woodtime
Evolution	Yukon
Gamut	Major

## > Contents by effect

WOOD - Legno  
MARBLE - Marmo  
STONE - Pietra  
CONCRETE - Cemento

## > Color Index

Color Index Major 20mm

## USE MANUAL: Installation Maintenance and Cleaning MANUALE D'USO: Posa, Manutenzione e Pulizia

MANUEL D'UTILISATION: Pose Entretien et Nettoyage  
GEBRAUCHSANWEISUNG: Verlegung, Wartung und Reinigung  
MANUAL DE USO: Colocación, Mantenimiento y Limpieza

★★★★★  
**MONOCIBEC**  
FINCIBEC GROUP

## USE MANUAL: INSTALLATION MAINTENANCE AND CLEANING

Fincibec logo

Fincibec logo

##### INSTALLATION

Installation of the material. Before installation it is important to carefully check the hue, size and choice of material, because claims are not accepted against installed materials whose defects were visible before laying. It is recommended that materials are ordered with an excess of 10 to 15% relative to the surface to be tiled, in order to effect repairs or to perfectly match the hue of one tile to the one laid previously.

During installation we advise you to draw the material from several boxes, especially if it comes from a range with a degree of colour shading and chromatic variation higher than V = 2 (refer to the General and collection catalogues). For veined products, such natural stones, it is recommended to arrange the grain of the slabs so as to obtain the best aesthetic and chromatic effect.

The installation can be effected either using cement dust or glue, with the use of specific high-performance adhesives for porcelain stoneware. It is advisable to use glue as it offers more guaranteed grip, especially with large formats. At the time of application, the substrate must be flat, stable, dry and mature, not frozen and not excessively hot, and it is necessary to follow the instructions of the manufacturers of materials for substrates and the specific adhesives used. Cementitious adhesives must be applied at room temperature, and generally between + 5 ° C and + 30/35 ° C. It is understood that also for installation it is recommended to follow the technical times indicated by the manufacturers of the adhesives used. The most suitable adhesives for laying of porcelain tiles can be identified based on the European Standard EN 12004 currently in force. Especially for lapped / polished products (but ideally for all other products), do not mark the material on its usable surface during installation with pencils (graphite) or permanent markers.

The use of double spreading is recommended for tiles with a side longer than 60cm in order to have a compact layer of adhesive as required by installation regulation UNI 11493.

##### JOINTS AND GROUTING

The joint width can vary according to the size of the tiles and the desired use of the flooring. The use of a single joint is not recommended; installation is recommended with a joint of at least 2mm for rectified products and 3 mm for unrectified materials or for materials for outdoor installation (this type of installation enables greater grip of the grout on the sides of the tiles, a greater absorption and compensation for any possible movements of the substrate). The regular use expansion joints is advised in large environments; instead it is sufficient to leave a slight gap between the material and the perimeter walls in the smallest environments. Skirtings will then cover the gap, giving a finished appearance. Always refer to the advice / suggestions of the designer or site manager.

In the case of "running bond" installation of the products in rectangular formats, we recommend staggering the longest side by a maximum of 10-15cm along the length of the adjacent piece. For large formats (as also provided for by UNI 11493) we advise use of the double spreading technique: the glue must be applied to both the back of the tile and on the wall / floor, thus ensuring the absence of gaps between ceramic and support . During the installation of the products it is appropriate to cover the floor with sheets fabric or paper/cardboard, in order to prevent any residual materials scratching the surface of the paving. For greater aesthetic value, we suggest using a grout in a colour that complements the tiles so as to reduce contrast, especially for lapped and rectified products. After grouting the porcelain tiles it is important, while it is still fresh, to remove any excess grout immediately with a sponge and plenty of water.

##### INSTALLATION ON EXISTING FLOORS

- Before installation, check the evenness of the surface and level if necessary. In all cases, prepare the perfect surface by cleaning to remove all traces of waxes, oils or residues that could compromise adhesion.
- Use joints of 2 mm and perimeter expansion joints. Respect all expansion joints underneath.
- Spread the adhesive on the floor with a suitable spatula; also spread the adhesive on the slab to be installed using the flat side of the trowel, in accordance with to "double spreading" method.
- It can be useful, in certain cases, to load edges and corners with an additional thickness of adhesive.
- Apply the slab and remove air gaps by carefully beating the surface to promote full adhesion taking care to keep the joints free from adhesive.

##### INSTALLATION OF WALL COVERINGS

These require the same operations as any other porcelain stoneware tile:

- Ensure evenness of the surfaces, levelling them if necessary.
- Use joints of at least 2 mm, respecting the use of expansion joints as below.
- Spread the adhesive on the wall using a suitable spatula.
- Apply the slab and remove air gaps by carefully beating the surface to facilitate full adhesion.

Use the most suitable porcelain tile adhesive for the type of wall being covered. Outdoors, provide for proper sizing of the joints and an appropriate pattern of elastic joints as a function of the substrate, the size and layout of the facade.

##### OUTDOOR INSTALLATION OF PORCELAIN STONEWARE TILES

For successful ceramic paving of exterior surfaces it is essential to select and use high quality tiles, but equally important is the presence of an experienced designer who can adapt, as a whole, the installation system to the specific loads required and the static situation of the surface upon which to intervene. In particular, the foundation layers must be adequate for such loads taking into consideration the possible need to use welded mesh in order to prevent possible settling of the underlying layers. The use of expansion joints, the techniques of application of the setting bed and the tiles must be carried out in accordance with the TECHNICAL REPORT CEN / TR 13548 "General requirements for the design and execution of ceramic tiling." Here follow some guidelines **for the installation of Monocibec outdoor flooring**:

1) Use of enhanced deformable cementitious adhesive, with extended open time (class C2E S1 according to EN 12004) for sizes up to 25cm x 25cm on cement screeds, structures in cast concrete and for waterproofing.

2) Use of enhanced deformable cementitious adhesive, with extended open time (class C2E S2 according to EN 12004) for larger tiles on cement screeds, structures in cast concrete and for waterproofing.

3) Apply the "double spreading" technique by means of a toothed spatula so as to have a full bed: this prevents the formation of voids that could provoke the stagnation of water with the accompanying risk of an increase in volume due to frost and the consequent detachment or breakage of the flooring.

4) Use of joints of not less than 3 mm and the application of expansion joints (width not less than 5 mm and utilized at least every 9-12 m2) to meet the address strong stresses due to diurnal / seasonal temperature changes to create support for the porcelain stoneware which has virtually zero coefficient of expansion.

5) The project gradients must be regular and at least 1.5% in order to allow an easy run-off of liquids. This must be created within the structure or by preparing a special sloping screed; varying the thickness of the setting bed to create a slope, as in the case of traditional cement laying, is not recommended.

Fincibec logo

##### CLEANING AFTER INSTALLATION

Cleaning is required following installation. Inadequate or late removal of the grouting used on the joints may leave hard-to-remove marks and create a cement film on the flooring capable of absorbing all types of dirt, thus giving the impression that the material itself is dirty.

a) Joints with grouting cement (class CG - EN 13888): to remove the excess grout cement, wash the floor with a solution of water + buffered acid (percentages of water / acid as shown on the packaging).

We recommend using the following products:

- Deterdek Pro - Fila
- Delta Plus - Kerakoll
- Ultracare Keranet - Mapei
- Ultracare Acid Cleaner - Mapei
- Cement Remover - Faber
- Solvacid - Geal Bel Chimica

b) Grout joints with epoxy filler (Class RG - EN13888) (not recommended for textured or lapped / polished surfaces until after testing in situ): It is critical not to leave epoxy residues - remove all excess material from the surface of the tile before it begins to harden, as subsequent removal could be very difficult. If residues and rings of epoxy grout are present, use a specific product and follow the instructions from the manufacturer:

We recommend using the following products:

- Fuga-Soap Eco - Kerakoll
- Ultracare Kerapoxy Cleaner - Mapei
- Epoxy Residue Remover - Faber Chimica
- CR10 - FILA
- Eposolv - Geal Bel Chimica

For both types of grout we recommend in the first phase the collection of coarse dirt and rubbing the detergent (diluted according to the manufacturer’s instructions) onto the tiling using a colourless cloth. We suggest performing a preliminary wash on a surface sample of a few square metres; in the case of a positive result, extend cleaning to the entire surface, and prevent the above detergents coming into contact with special or decorated pieces and elements of aluminium, steel, natural stone (e.g. marble). During the detergent’s action time (set by the manufacturer on the label) scrub the dirt and grime with Scotch-Brite pads or a cellulose sponge. Subsequently, rinse the flooring with water to ensure that it is free of detergent and dirt residues. For polished/lapped materials and special or decorated pieces, be sure to proceed with the cleaning of excess grout and cement mortar before they dry out, in order to avoid the subsequent use of abrasive sponges on shiny surfaces which could lead to scratching.

After the acid wash it may be necessary to perform a basic or alkaline wash using degreasing detergents. This is because the acid wash can leave an oilness on the flooring that could attract dirt. For alkaline detergents we recommend the use of the following products:

- PS 87 PRO - Fila
- Ultracare HD Cleaner - Mapei
- Wax remover - Faber Chimica
- Deterflash - Geal Bel Chimica

Fincibec logo

##### ROUTINE MAINTENANCE AND DAILY CLEANING

After "after installation" cleaning (previous chapter), for good maintenance of Monocibec ceramic surfaces clean with common neutral detergent diluted in hot water is sufficient, always following the manner specified on the packaging. Please pay close attention to the phases of rinsing and drying of the flooring, allowing you to remove dirt and avoid accumulation (stratification) of limescale, detergent and dirt residues.

The products that we recommend for this purpose are the following:

- Fila Cleaner - Fila
- Ultracare Multicleaner - Mapei
- Tile Cleaner - Faber Chimica
- Bel Gres - Geal Bel Chimica

We strongly advise against the use of waxes, oily soaps, impregnating agents and hydro-oil repellent treatments on the porcelain stoneware product where their application is not necessary. Hydrofluoric acid (HF) and its derivatives irreparably damaging all ceramic products, so it is always important to make sure not to use products containing these chemicals (sometimes present in some items for the special cleaning of bathrooms, showers surfaces, etc.)

##### SPECIAL CLEANING

In the case of particular and / or particularly stubborn stains, or for special cleaning of the entire floor, it is advisable to use specific detergents as indicated in the table below. It should also be emphasized that the removal of any type of stain is easier if it is removed while still fresh. In particular, with lapped or polished porcelain tiles it is important to perform a preventive test before using detergent products.

Fincibec logo

Fincibec is a member of

ASSO POSA

## MANUALE D’USO: POSA, MANUTENZIONE E PULIZIA

Fincibec logo

Fincibec logo

##### POSA IN OPERA

La posa in opera del materiale. Prima della posa in opera è importante verificare accuratamente il tono, il calibro e la scelta del materiale, in quanto non vengono accettati reclami su materiale già posato, i cui difetti fossero visibili prima della posa. Si raccomanda di realizzare ordini di materiale con una eccedenza del 10 o 15 % rispetto alla superficie da piastrellare nel caso si debbano realizzare nel tempo riparazioni di varia natura poiché ordini successivi di piastrelle potrebbero avere un tono non perfettamente abbinabile con quello utilizzato in precedenza.

Durante la posa consigliamo di prelevare sempre il materiale attingendo da più scatole, soprattutto se si tratta di serie con un grado di stonalizzazione e variazione cromatica superiore a V = 2 (rif. catalogo generale e per collezione). Per prodotti venati, come per le pietre naturali, si raccomanda di disporre la venatura delle lastre in modo da ottenere il migliore effetto estetico e cromatico.

La posa può essere realizzata sia a spolvero di cemento, sia a colla, con l'utilizzo di collanti specifici ad elevate prestazioni per gres porcellanato. Si consiglia comunque la posa a colla in quanto offre maggiori garanzie di tenuta, specialmente su grandi formati. Al momento della posa, il sottofondo deve essere planare, stabile, asciutto e maturo, non gelato e non eccessivamente caldo e comunque è necessario seguire le istruzioni dei produttori dei materiali per sottofondi e collanti specifici utilizzati. Gli adesivi cementizi devono essere applicati a temperatura ambiente, ed in genere compresa tra +5° C e + 30/35° C. Resta inteso che anche per la posa si consiglia di rispettare i tempi tecnici indicati dai produttori dei collanti utilizzati. I collanti più adatti alla posa del gres porcellanato si possono identificare sulla base della Normativa Europea attualmente in vigore EN12004. In particolar modo per i prodotti lappati/levigati, ma è comunque buona norma anche per tutti gli altri prodotti, non segnare durante le operazioni di posa il materiale sulla superficie di utilizzo con matite (grafite) o pennarelli indelebili.

E' raccomandato l'utilizzo della doppia spalmatura per piastrelle con un lato di lunghezza maggiore di 60cm per avere uno strato compatto di adesivo così come prescritto dalla norma sulla posa UNI 11493.

##### I GIUNTI E LE STUCCATURE

La larghezza della fuga può variare anche in funzione delle dimensioni delle piastrelle e della destinazione d'uso del pavimento. E' sconsigliata la posa a giunto unito mentre è consigliata una posa con fuga di almeno 2 mm per il prodotto rettificato e almeno 3 mm per il materiale non rettificato o per posa di materiale per esterno (questo tipo di posa consente una maggior presa del fugante sui fianchi delle piastrelle, un maggior assorbimento e compensazione di eventuali movimenti del sottofondo). Si consiglia di posizionare con regolarità dei giunti di dilatazione negli ambienti grandi, è invece sufficiente lasciare un leggero stacco tra il materiale e i muri perimetrali negli ambienti più piccoli. Sarà poi il battiscopa a coprire lo stacco, dando un aspetto di finitura. Si rimanda comunque ai consigli/suggerimenti del progettista o direttore di cantiere. Nel caso si scelga la posa "a correre" dei prodotti in formati rettangolari, si consiglia di stalsare il lato più lungo per un massimo di 10-15 cm sulla lunghezza del pezzo adiacente. Per i grandi formati (come previsto anche dalla norma UNI 11493) si consiglia di utilizzare la tecnica della doppia spalmatura: il collante deve essere applicato sia sul retro della piastrella che sulla parete/pavimento, garantendo così l'assenza di vuoti tra ceramica e supporto. Durante la posa dei prodotti è opportuno ricoprire il pavimento con teli e cartoni già in fase di posa, in modo tale da impedire che eventuali materiali residui vadano a scalfire la superficie della pavimentazione.

Per una maggior valenza estetica, suggeriamo gli stucchi in cadenza di colore con la piastrella onde ridurre il contrasto soprattutto per prodotti lappati e rettificati. Dopo la stuccatura delle piastrelle in gres porcellanato è importante, a stucco ancora fresco, rimuovere immediatamente in modo accurato con spugna ed acqua abbondante lo stucco in eccesso.

##### POSA SU PAVIMENTI PREESISTENTI

- Prima della posa verificare la planarità delle superfici e livellare se necessario. In ogni caso prevedere la perfetta pulizia delle superfici eliminando ogni traccia di cere, oli o residui che possano compromettere l'adesione.
- Prevedere fughe di 2 mm. e giunti di dilatazione perimetrali. Rispettare tutti i giunti di dilatazione sottostanti.
- Stendere la colla sul pavimento sottostante con una idonea spatola; stendere la colla anche sulla lastra da posare con la parte liscia della spatola secondo il metodo della doppia spalmatura.
- Può essere utile, in determinati casi, caricare spigoli e angoli con un ulteriore spessore di adesivo.
- Applicare la lastra ed eliminare i vuoti d'aria battendo con cura la superficie per favorire un'adesione completa avendo cura di mantenere le fughe libere da adesivo.

Fincibec logo

##### POSA DA RIVESTIMENTO DI PARETI

Sono richieste le medesime operazioni di una qualunque piastrella di gres porcellanato:

- Verificare la planarità delle superfici, livellando se necessario.
- Prevedere fughe di almeno 2 mm. Rispettando i giunti di dilatazione sottostanti.
- Stendere l'adesivo sulla parete utilizzando una idonea spatola.
- Applicare la lastra ed eliminare i vuoti d'aria battendo con cura la superficie per favorire un adesione completa.

Utilizzare come collante adesivi per gres porcellanato scegliendo la tipologia adatta alla natura della parete da rivestire. In esterno prevedere un corretto dimensionamento delle fughe ed un appropriato reticolo di giunti elastici in funzione del sottofondo, delle dimensioni e della planimetria della facciata

##### POSA DI GRES PORCELLANTO IN ESTERNO

Per la buona riuscita di una pavimentazione in ceramica di superfici esterne, è indispensabile la scelta e l'utilizzo di piastrelle di qualita superiore, ma è altrettanto importante la presenza di un progettista esperto che possa adeguare, nel suo complesso, il sistema di posa ai carichi specifici richiesti ed alla situazione statica della superficie sulla quale intervenire. In particolare gli strati di sottofondo debbono essere dimensionati a tali carichi considerando l'eventuale necessità di utilizzo di reti elettrosaldate per prevenire possibili assestamenti degli strati sottostanti. Il progetto dei giunti di deformazione, le tecniche di applicazione dell'allettamento e delle piastrelle debbono essere eseguiti nel rispetto del RAPPORTO TECNICO CEN/TR 13548 "Regole generali per la progettazione e l'esecuzione delle piastrellature ceramiche". Di seguito alcune indicazioni **per la posa di pavimenti in esterno Monocibec**:

1) Utilizzo di adesivi cementizi migliorati con tempo aperto allungato deformabile (classe C2E S1 secondo EN 12004) per formati fino a 25cmx25cm su massetti cementizi, strutture in getto di calcestruzzo e impermeabilizzazioni

2) Utilizzo di adesivi cementizi migliorati con tempo aperto allungato altamente deformabile (classe C2E S2 secondo EN 12004) per dimensioni di piastrelle di formati maggiori su massetti cementizi, strutture in getto di calcestruzzo e impermeabilizzazioni

3) Applicare la tecnica della doppia spalmatura per mezzo di spatola di idonea dentatura in modo da avere un letto pieno: questo permette di evitare la formazione di vuoti che provocherebbero il ristagno di acqua con il rischio di aumento di volume dovuto al gelo ed il conseguente distacco o rottura della pavimentazione.

4) Utilizzo di fughe non inferiori ai 3 mm ed esecuzione di giunti di dilatazione (di ampiezza non inferiori ai 5 mm e realizzati almeno ogni 9-12 m2) per sofferire ai forti stati tensionali dovuti all'escursione termica diurna/stagionale che si vengono a creare tra il gres porcellanato che ha coefficiente di dilatazione praticamente nullo e il supporto.

5) Le pendenze di progetto debbono essere regolari ed almeno dell'1,5% per consentire un facile deflusso dei liquidi. Debbono essere realizzate nella struttura stessa, o predisponendo uno speciale massetto in pendenza; è sconsigliato, nel caso di posa tradizionale a malta cementizia, tentare di realizzare la pendenza variando lo spessore dell'allettamento.

Fincibec logo

Fincibec logo

##### IL LAVAGGIO "DOPO POSA"

Il lavaggio "dopo posa" è obbligatorio a fine cantiere. La rimozione inadeguata o tardiva dei residui della stuccatura utilizzata per le fughe, può lasciare alonature difficili da rimuovere e creare sulla pavimentazione un film cementizio capace di assorbire ogni forma di sporco, dando così l'impressione che sia il materiale a sporcarsi.

a) Fughe con stucco cementizio (Classe CG – EN 13888): per rimuovere gli eccessi di stucchi cementizi, lavare il pavimento con la soluzione acqua + acido tamponato (percentuali di acqua/acido come riportato sulla confezione).

Si consiglia l'utilizzo dei seguenti prodotti:

- Deterdek Pro - Fila
- Delta Plus - Kerakoll
- Ultracare Keranet - Mapei
- Ultracare Acid Cleaner - Mapei
- Cement Remover - Faber
- Solvacid - Geal Bel Chimica

b) Fughe con stucco epossidico (Classe RG – EN13888) (non consigliati per superfici strutturate o lappate/levigate se non dopo aver realizzato prova in cantiere): è fondamentale non lasciare residui di epossidico a fine lavori asportando tutto il materiale in eccesso sulla superficie della piastrella prima che inizi ad indurirsi in quanto risulterebbe molto difficile la successiva rimozione. Nel caso siano ancora presenti residui e aloni di stucco epossidico utilizzare un prodotto specifico seguendo le istruzioni riportate dal produttore:

Si consiglia l'utilizzo dei seguenti prodotti:

- Fuga-Soap Eco - Kerakoll
- Ultracare Kerapoxy Cleaner - Mapei
- Epoxy Residue Remover - Faber Chimica
- CR10 - FILA
- Eposolv - Geal Bel Chimica

Per entrambi i tipi di stucco suggeriamo di raccogliere in prima fase lo sporco grossolano e distribuire strofinando con l'ausilio di uno straccio incolore i detergenti sulla piastrellatura diluiti secondo le indicazioni del produttore. Sugeriamo di eseguire un lavaggio preliminare su una superficie campione di alcuni metri quadrati; in caso di esito positivo, estendere la pulizia su tutta la superficie ed evitare che suddetti detergenti vengano a contatto con pezzi speciali ed elementi di alluminio, acciaio, pietre naturali (es: marmo). Durante il tempo di azione dei detergenti (stabiliti dal fornitore sull'etichetta) strofinare lo sporco più ostinato con tamponi Scotch-Brite o con spugna di cellulosa. Successivamente si procederà poi a risciacquare abbondantemente la pavimentazione con acqua per assicurarsi che il pavimento sia privo di residui di detergenti e sporco. Per i materiali levigati/lappati e pezzi speciali/decori assicurarsi di procedere con la pulizia dei residui di stucco e malta cementizia prima che questi si essicchino in modo da escludere l'utilizzo di spugne abrasive sulle pregiate superfici lucide che potrebbero graffiarsi. Una volta effettuato il lavaggio acido, potrebbe essere necessario eseguire un lavaggio basico o alcalino utilizzando detersivi sgrassanti. Questo perchè il lavaggio acido può lasciare untuosità sul pavimento che potrebbe contribuire a trattenere lo sporco. Come detergente alcalino consigliamo l'utilizzo dei seguenti prodotti:

- PS 87 PRO - Fila
- Ultracare HD Cleaner - Mapei
- Wax remover - Faber Chimica
- Deterflash - Geal Bel Chimica

Fincibec logo

##### MANUTENZIONE ORDINARIA E PULIZIA QUOTIDIANA

Dopo avere effettuato la pulizia "dopoposa" (capitolo precedente), per una buona manutenzione ordinaria delle superfici ceramiche Monocibec è sufficiente una pulizia con comuni detergenti neutri diluiti in acqua calda, seguendo sempre le modalità riportate sulle confezioni. Si consiglia di prestare molta attenzione alla fase di risciacquo e di asciugatura del pavimento, che consente di rimuovere lo sporco e di evitare accumuli (stratificazioni) di calcare, di detergente e residui di sporco. I prodotti che consigliamo per questo scopo sono i seguenti:

- Fila Cleaner - Fila
- Ultracare Multicleaner - Mapei
- Tile Cleaner - Faber Chimica
- Bel Gres - Geal Bel Chimica

Si sconsiglia vivamente l'impiego di cere, saponi oleosi, impregnanti e trattamenti vari (idro-ole repellenti) sul prodotto in gres porcellanato la cui applicazione non è necessaria.

L'acido Fluoridrico (HF) e i suoi derivati danneggiano irrimediabilmente tutti i prodotti ceramici, quindi è sempre importante assicurarsi di non utilizzare prodotti contenenti tali sostanze chimiche (a volte presenti in alcuni articoli per la pulizia straordinaria di bagni, superfici di docce, ecc)

##### PULIZIE STRAORDINARIE

In caso di macchie particolari e/o particolarmente tenaci, o per una pulizia straordinaria di tutta la pavimentazione, è consigliabile l'uso di detergenti specifici come meglio indicato nella tabella proposta di seguito. Va inoltre sottolineato come la rimozione di qualsiasi tipo di macchia sia più agevole se rimossa quando questa è ancora fresca. In particolare su gres porcellanato lappato o levigato e' importante fare sempre un test preventivo prima dell'uso dei prodotti detergenti.

Fincibec logo

Fincibec è socio di

ASSO POSA

# Index

The Company  
Technology

Sizes

Thicknesses

Surfaces

Porcelain stoneware

Ecologycare

Certifications

Quality and Safety

Ceramic of Italy

Fincibec Group

Campus

Engineering

Pools & Wellness

Facades

Raised Flooring

**Technical Specifications**

Fincibec logo

Fincibec logo

Fincibec logo

Fincibec logo

Fincibec logo

Fincibec logo

Fincibec logo

Fincibec logo

Fincibec logo

Fincibec logo

Fincibec logo

Fincibec logo

Fincibec logo

Fincibec logo

Fincibec logo

Fincibec logo

Fincibec logo

Fincibec logo

Fincibec logo

Fincibec logo

Fincibec logo

Fincibec logo

Fincibec logo

Fincibec logo

Fincibec logo

Fincibec logo

Fincibec logo

Fincibec logo

Fincibec logo

Fincibec logo

Fincibec logo

Fincibec logo

Fincibec logo

Fincibec logo

Fincibec logo

Fincibec logo

Fincibec logo

Fincibec logo

Fincibec logo

Fincibec logo

Fincibec logo

Fincibec logo

Fincibec logo

Fincibec logo

Fincibec logo

Fincibec logo

Fincibec logo

Fincibec logo

Fincibec logo

Fincibec logo

Fincibec logo

## MANUEL D’UTILISATION: POSE ENTRETIEN ET NETTOYAGE

Pose

Pose

Pose

**POSE**
La pose du matériau. Avant la pose, vérifier soigneusement les nuances, les calibres et le choix du matériau, car aucune réclamation sur matériel posé n’est acceptée, si les défauts étaient visibles avant la pose. Il est recommandé de réaliser des commandes de matériau avec une quantité supplémentaire de 10% ou 15% par rapport à la surface à carreler au cas où des réparations de différentes natures devraient être effectuées à l’avenir, étant donné que des commandes futures de carreaux pourraient avoir une nuance ne correspondant pas parfaitement à celle utilisée précédemment.

Pendant la pose, nous conseillons de toujours prendre le matériau à partir de plusieurs boîtes, surtout s’il s’agit de séries ayant un degré de variation chromatique supérieur à V = 2 (réf. catalogue général et pour collection) Pour les produits veinés, comme pour les pierres naturelles, il est recommandé de disposer le veinage des plaques de manière à obtenir un effet esthétique et chromatique parfait.

La pose peut être réalisée par saupoudrage de ciment ou à la colle, en utilisant des liants spécifiques dotés de grandes prestations pour le grès cérame Quoiqu'il en soit, nous conseillons la pose collée étant donné que celle-ci garantit une étanchéité majeure, en particulier sur des grands formats. Au moment de la pose, la sous-couche doit être plane, stable, sèche et mature, ni gelée, ni excessivement chaude et, dans tous les cas, il est indispensable de suivre les instructions des fabricants des matériaux pour les sous-couches et les liants spécifiques utilisés. Les ciments-colle doivent être appliqués à température ambiante et, en général, comprise entre +5° C et + 30/35° C. Il est bien évident qu’il est conseillé de respecter les délais techniques indiqués par les fabricants des liants utilisés. Pour établir les liants les plus adaptés au grès cérame, consulter la norme européenne EN12004, actuellement en vigueur. La règle suivante s’applique tout particulièrement aux produits polis, mais elle est valable aussi pour tous les autres produits : pendant les opérations de pose, ne pas marquer le matériau sur la surface d’utilisation avec des crayons (graphite) ni des feutres indélébiles.

Il est recommandé d'utiliser un double encollage pour les carreaux des bords d'une longueur supérieure à 60 cm afin d'obtenir une couche compacte de colle, conformément à la norme sur la pose UNI 11493.

**LES JOINTS ET JOINTOIEMENTS**
La largeur du joint peut varier en fonction des dimensions des carreaux et de la destination d’usage du sol. Nous déconseillons la pose à joint fermé. Nous recommandons plutôt un jointoiment d’au moins 2 mm pour un produit rectifié et de 3 mm pour un produit non rectifié ou pour la pose du matériau en extérieur. Ce type de pose permet une meilleure prise du joint sur les bords du carreau, une meilleure absorption et une meilleure compensation des mouvements éventuels de la sous-couche. Dans les grands espaces, il est conseillé de positionner les joints de dilatation avec une certaine régularité ; par contre, il est suffisant de laisser un léger espace entre le matériel et les murs de périmètre dans les pièces plus petites. La plinthe se chargera de remplir l’écart et de donner un aspect fini et uniforme. Dans tous les cas, il est recommandé de suivre les conseils/suggestions du concepteur ou du chef de chantier.

En cas de pose « à joints décalés » des produits rectangulaires, il est conseillé de décaler le côté le plus long sur un maximum de 10-15 cm par rapport à la longueur du carreau adjacent. Pour les grands formats (conformément, aussi, aux dispositions de la norme UNI 11493), il est conseillé d’utiliser la technique du double encollage. Le liant doit être appliqué au dos du carreau et sur le mur/sol, afin de garantir l’absence de vides entre la céramique et le support. Pendant la pose des produits, il convient de recouvrir le sol avec des bâches et des cartons, dès la phase de pose, de façon à empêcher que du matériel résiduel éventuel ne raye la surface des carreaux.

Pour une plus grande valeur esthétique, nous suggérons les mortiers ayant une tonalité assortie au carreau pour réduire le contraste, surtout pour les produits polis et rectifiés. Après le jointoiment des carreaux en grès cérame, il est important de retirer avec soin, lorsque le mortier est encore frais, l’excès de mortier avec une éponge et une grande quantité d’eau.

- POSE SUR DES SOLS DEJA EXISTANTS**
- Avant la pose, contrôler la planéité des surfaces et niveler, si nécessaire. Dans tous les cas, prévoir un nettoyage parfait des surfaces afin d’éliminer toute trace de cire, d’huile ou de résidu pouvant compromettre l’adhérence.
  - Prévoir des joints de 2 mm et des joints de dilatation sur le contour. Respecter tous les joints de dilatation sous-jacents.
  - Passer le liant sur le sol sous-jacent à l’aide d’une spatule adaptée; étendre le liant sur la dalle à poser avec la partie lisse de la spatule selon la méthode du double encollage.
  - Dans certains cas, il peut être utile de charger les arêtes et les angles avec une quantité de colle supplémentaire.
  - Poser la dalle et éliminer les vides d’air en tapant avec précaution la surface pour favoriser une adhérence complète, en ayant soin de garder les joints libres de toute colle.

**POSE POUR REVETEMENTS MURAUX**
Les opérations à exécuter sont les mêmes que celles s’appliquant à tout carreau en grès cérame.

- Vérifier la planéité des surfaces et niveler, si nécessaire.
- Prévoir des joints d’au moins 2 mm. Respecter tous les joints de dilatation sous-jacents.
- Appliquer la colle sur le mur à l’aide d’une spatule adaptée.
- Poser la dalle et éliminer les vides d’air en tapant avec précaution la surface pour favoriser une adhérence parfaite.

Utiliser comme liant des produits pour grès cérame en choisissant le type adapté à la nature du mur devant être revêtu. Pour les applications en extérieur, déterminer la bonne dimension de joints et prévoir une configuration de joints de dilatation appropriée, en fonction de la sous-couche, des dimensions et de la planimétrie de la façade.

**POSE DE GRÈS CÉRAME A L’EXTERIEUR**
Pour la bonne réussite d’un carrelage céramique sur des surfaces extérieures, il est indispensable de choisir et d’utiliser des carreaux de qualité supérieure et il est tout aussi important de faire appel à un expert capable d’adapter, dans son ensemble, le système de pose aux charges spécifiques requises et à la situation statique de la surface sur laquelle intervenir. En particulier, les couches de support doivent avoir des dimensions adaptées à ces charges et prendre en compte la nécessité éventuelle d’utiliser des treillis soudés électriquement pour éviter tout tassement des couches sous-jacentes. La conception des joints de déformation, les techniques d’application de la chape et des carreaux doivent être effectués conformément au RAPPORT TECHNIQUE CEN/TR 13548 « Règles générales pour la conception et l’exécution des carrelages céramiques ». Les points suivants fournissent quelques indications **pour la pose de revêtements de sol Monocibec, en extérieur :**

- Utiliser des mortiers-collés améliorés, déformables, à temps ouvert allongé (classe C2E S1 conformément à la norme EN12004) destinés aux formats allant jusqu’à 25 cm x 25 cm, sur des fondations en béton, des structures en béton et d'imperméabilisation.
- Utiliser des mortiers-collés améliorés, hautement déformables, à temps ouvert allongé (classe C2E S2

Pose

Pose

Pose

conformément à la norme EN12004) destinés à des dimensions de carreaux de formats supérieurs, sur des fondations en béton, des structures en béton et d'imperméabilisation.

3) Appliquer la technique du double encollage à l’aide d’une spatule d’une denture adaptée de manière à avoir une couche pleine et ininterrompue : ceci permet d’éviter la formation de vides qui provoqueraient la stagnation d’eau avec le risque d’augmentation du volume due au gel et le détachement ou la rupture successives du carrelage.

4) Utiliser des joints d’au moins 3 mm et exécuter des joints de dilatation (d’au moins 5 mm et réalisés au minimum tous les 9-12 mm2) pour répondre aux fortes tensions dues à la forte amplitude thermique diurne/saisonnière, qui se créent entre le grès cérame qui a un coefficient de dilatation presque nul et le support.
5) Les inclinaisons prévues dans le projet doivent être régulières et d’au moins 1,5% pour permettre un écoulement facile des liquides. Celles-ci doivent être réalisés dans la structure elle-même ou en prévoyant une fondation spéciale inclinée. Dans le cas d’une pose traditionnelle avec laitier de ciment, d’essayer de réaliser la pente en modifiant l’épaisseur de la chape.

##### LE LAVAGE « APRÈS POSE »

Le lavage « après pose » est obligatoire en fin de chantier. Si les résidus de mortier sont retirés de façon incorrecte ou trop tard, des auréoles tenaces et une pellicule de ciment peuvent se former. Cette dernière peut absorber toutes les saletés et donner ainsi l'impression que le sol est sale.

a) Joints avec mortiers à base de ciments (Classe C6 – EN 13888) : pour éliminer les excès de mortiers à base de ciment, laver le sol avec la solution eau + acide tamponné (pourcentages d’eau/acide conformés aux indications figurant sur l’emballage).

Il est conseillé d'utiliser les produits suivants :

- Deterdek Pro - Fila
- Delta Plus - Kerakoll
- Ultracare Keranet - Mapei
- Ultracare Acid Cleaner - Mapei
- Cement Remover - Faber
- Solvacid - Geal Bel Chimica

b) Joints avec mortier époxy (Classe RG - EN 13888) (déconseillés pour les surfaces structurelles ou polies/lissées, à moins d’avoir réalisé un essai sur place) : il est indispensable de ne laisser aucun résidu d'époxy à la fin des travaux. Pour cela, retirer toute la matière excessive de la surface du carreau avant qu'elle ne commence à durcir dans la mesure où il serait extrêmement difficile de l'éliminer par la suite. Si des résidus et des traces de mortier époxy sont encore présents, utiliser un produit spécifique et suivre les instructions fournies par le fabricant.

Il est conseillé d'utiliser les produits suivants :

- Fuga-Soap Eco - Kerakoll
- Ultracare Kerapoxy Cleaner - Mapei
- Epoxy Residue Remover - Faber Chimica
- CR10 - FILA

- Eposolv - Geal Bel Chimica

Pour les deux types de mortier, nous suggérons de récupérer, dans un premier temps, la plus grande partie de la saleté, et ensuite de distribuer les détergents sur le carrelage, en frottant avec un chiffon incolore, et conformément aux indications du fabricant. Nous conseillons d’effectuer un lavage préliminaire sur un échantillon de la surface de quelques mètres carrés. Si le résultat est positif, étendre le nettoyage à toute la surface et éviter que les détergents susmentionnés n’entrent en contact avec des pièces spéciales et des éléments en aluminium, en acier ou en pierres naturelles (par ex. : marbre). Pendant le temps d’action des détergents (indiqué par le fournisseur, sur l’étiquette), frotter la saleté la plus incrustée avec des tampons Scotch-Brite ou à l’aide d’une éponge végétale de cellulose. Ensuite, on rincera abondamment le sol avec l’eau afin de s’assurer que le sol est exempt de tout résidu de détergent et de saleté. Pour les matériaux polis/lissés et les pièces spéciales/décoratives, s’assurer de nettoyer les résidus de mortier et de laitier de ciment avant qu’ils ne séchent de manière à éviter l’utilisation des éponges abrasives sur les surfaces précieuses brillantes qui pourraient être rayées.

Une fois que le lavage acide a été effectué, il peut être nécessaire de procéder à un lavage basique ou alcalin avec des produits de nettoyage dégraissants. En effet, les détergents acides peuvent laisser sur le sol des traces de gras qui pourraient retenir la saleté. Comme détergent alcalin nous conseillons l’utilisation des produits suivants :

- PS87 PRO - Fila
- Ultracare HD Cleaner - Mapei
- Wax remover - Faber Chimica
- Deterflash - Geal Bel Chimica

##### ENTRETIEN ORDINAIRE ET NETTOYAGE QUOTIDIEN

Après le nettoyage « après pose » (chapitre précédent), pour un bon entretien ordinaire des surfaces céramiques Monocibec, il suffit de procéder à un nettoyage avec des produits nettoyants neutres dilués à l’eau chaude, en suivant toujours les instructions indiquées sur les emballages. Il est conseillé de faire très attention au rinçage et au séchage du sol afin de bien éliminer la saleté et d’éviter l’accumulation (formation de couches) de calcaire laissée par le détergent et les résidu de saleté. A cet égard, nous conseillons les produits suivants :

- Fila Cleaner - Fila
- Ultracare Multicleaner - Mapei
- Tile Cleaner - Faber Chimica
- Bel Gres - Geal Bel Chimica

Il est vivement déconseillé d'utiliser, sur le produit en grès cérame, des cires, des savons gras, des agents d'imprégnation et autres traitements (hydro-oléofuges) dont l'application n'est pas nécessaire. L'acide fluorhydrique (HF) et ses dérivés endommagent tous les produits céramiques de manière irrémédiable. Il est donc toujours important de s'assurer de ne pas utiliser des produits contenant ces substances chimiques (parfois présentes dans certains articles pour le nettoyage particulier de salles de bain, surfaces de douche etc.).

##### NETTOYAGE EXCEPTIONNEL

En cas de taches spécifiques et/ou particulièrement tenaces, ou pour un nettoyage extraordinaire de tout le carrelage, il est conseillé d'utiliser des détergents spécifiques comme indiqué dans le tableau ci-dessous. De plus, il convient de ne pas oublier qu'il est plus facile d'enlever une tache quand celle-ci est encore fraîche Il est important de faire toujours un test avant l'utilisation de ces détergents et notamment sur le grès cérame lissé ou poli.

Fincibec est membre de 



## GEBRAUCHSANWEISUNG: VERLEGUNG, WARTUNG UND REINIGUNG

Pose

Pose

Pose

**VERLEGUNG**
Die Verlegung des Materials. Vor der Verlegung müssen Farbton, Größe und Materialqualität sorgfältig geprüft werden, da Beanstandungen für bereits verlegtes Material, dessen Defekte schon vor dem Verlegen sichtbar waren, nicht angenommen werden. Wir empfehlen, bei der Bestellung etwa 10 - 15 % mehr Material zu bestellen als die zu fließende Oberfläche, falls eventuelle zukünftige Reparaturen ausgeführt werden müssen, denn bei nachfolgenden Bestellungen könnten die Fliesen farblich nicht perfekt mit dem zuvor verwendeten Material übereinstimmen.

Während der Verlegung raten wir, immer Material aus verschiedenen Verpackungen zu verwenden, vor allem bei einer Serie mit hohem Farbspiel von über V = 2 (Bez. Allgemeiner Katalog und Produktreihe). Bei geaderten Produkten und Natursteinen wird empfohlen, die Aderung der Fliesen so zu verlegen, dass die bestmögliche optische Wirkung und Farbton erreicht werden.

Es kann sowohl im Mörtelbett- als auch im Dünnbettverfahren mit Fliesenkleber verlegt werden. Dabei müssen spezifische Fliesenkleber mit hoher Leistung für Feinsteinzeug verwendet werden. Wir empfehlen das Verlegen mit Fliesenkleber, da dies eine bessere Haftung gewährleistet, vor allem bei großen Formaten. Beim Verlegen muss der Untergrund eben, stabil, trocken und bereit sein. Er darf weder gefroren noch zu heiß sein. Die Angaben des Unterbodenherstellers und der spezifischen Kleber müssen befolgt werden. Zementkleber müssen bei Raumtemperatur verarbeitet werden, normalerweise bei Temperaturen zwischen +5° C und + 30/35° C. Es versteht sich von selbst, dass beim Verlegen die Zeitangaben des Kleberherstellers beachtet werden müssen. Diese Fliesenkleber, die sich am besten zum Verlegen von Feinsteinzeug eignen, können mit Hilfe der derzeit geltenden Europäischen Norm EN12004 identifiziert werden. Vor allem geläppte/geschliffene Produkte, aber ganz allgemein auch alle anderen Produkte, sollten während des Verlegens an der Oberfläche nicht mit Bleistiften (Graphit) oder mit Permanent Markern gekennzeichnet werden. Es wird empfohlen, bei Fliesen mit einer Länge von über 60cm eine doppelseitige Schicht aufzutragen, damit eine kompakte Schicht erreicht wird, wie es von der Norm UNI 11493 beim Verlegen vorgeschrieben wird.

**FUGEN UND VERFUGEN**
Die Fugenbreite kann sich anhand der Fliesengröße und dem Verwendungszweck des Fußbodens verändern. Aneinander stoßende Fugen werden nicht empfohlen. Beim Verlegen sollte eine Fuge von mindestens 2 mm bei geschliffenem Material und 3 mm bei nicht geschliffenem Material oder beim Verlegen von Material für den Außenbereich bestehen (diese Verlegungsweise erlaubt einen besseren Griff des Fugenmaterials an der Fliesenseite und bessere Aufnahme und Ausgleich eventueller Bewegungen des Unterbodens). Es wird empfohlen, in größeren Räumen regelmäßig Ausgleichsfugen zu lassen; bei kleineren Räumen ist hingegen ausreichend, zwischen Material und Wand einen kleinen Abstand einzuhalten. Die Fußleiste wird dann diesen Abstand abdecken und das Aussehen vollenden. Wir verweisen trotzdem auf Ratschläge/Empfehlungen des Konstrukteurs oder Bauleiters. Sollte eine "fortlaufende Verlegung" rechteckiger Produkte gewählt werden, so wird empfohlen, die längere Seite maximal um 10-15 cm an der Länge des angrenzenden Stücks zu versetzen. Bei Großformaten (wie auch von der Norm UNI 11493 vorgesehen) wird empfohlen, die Technik der doppelseitigen Beschichtung zu verwenden: der Kleber wird sowohl auf der Fliesenrückseite als auch an der Wand/am Boden aufgetragen, wodurch Leerräume zwischen der Keramik und dem Träger vermieden werden. Beim Verlegen der Fliesen empfiehlt es sich, den Boden mit Plastikplanen oder Karton abzudecken, damit eventuelles Restmaterial die Fußbodenoberfläche nicht verschrammt.

Für einen besseren optischen Effekt sollte Stück im Tonfall der Fliesen gewählt werden, um Kontraste, vor allem bei geläpntem und zugschliffenem Material, zu verringern. Nach dem Verspachteln der Feinsteinzeugfliesen ist es wichtig, den überschüssigen Stuck sofort mit einem Schwamm und ausreichend Wasser sorgfältig zu entfernen, solange dieser noch frisch ist.

- VERLEGEN AUF SCHON VORHANDENEN FUSSBÖDEN**
- Vor dem Verlegen prüfen, ob die Oberfläche eben ist, eventuell nivellieren. Die Oberfläche muss auf jeden Fall sorgfältig gereinigt werden. Wachsreste, Öle oder Restmaterial, die die Haftung einschränken könnten, müssen werden entfernt.
  - Es werden Fugen von 2 mm und Ausgleichsfolie an den Wänden vorgesehen. Alle darunter liegenden Ausgleichsfugen beachten.
  - Den Kleber mit einem Spachtel auf den darunter liegenden Boden auftragen: den Kleber auch auf die zu verlegende Fliese mit der glatten Seite des Spachtels, nach der Methode der doppelseitigen Beschichtung, auftragen.
  - Es kann in gewissen Fällen sinnvoll sein, Kanten und Ecken mit weiterem Kleber zu verstärken.
  - Fliese aufbringen und Luftblasen durch sanftes Klopfen auf die Oberfläche entfernen, wodurch eine vollständige Haftung entsteht. Es darf sich kein Kleber in den Fugen befinden.

**VERLEGEN VON WANDVERKLEIDUNGEN**
Auch hier sind die gleichen Arbeitsvorgänge für Fliesen aus Feinsteinzeug vorgesehen:

- Die Oberfläche auf Ebenheit prüfen, eventuell nivellieren.
- Fugen von mindestens 2 mm vorsehen. Darunter liegende Ausgleichsfugen beachten.
- Den Kleber mit einem geeigneten Spachtel auftragen.
- Fliese ansetzen und Luftblasen durch sanftes Klopfen auf die Oberfläche entfernen, wodurch eine vollständige Haftung entsteht.

Dazu einen Kleber wählen, der für Feinsteinzeug und der Beschaffenheit der Wand geeignet ist. Im Außenbereich die Fugen richtig bemessen und ein Gitter elastischer Fugen vorsehen, die dem Untergrund, den Ausmaßen und Lageplan der Fassade entsprechen.

**VERLEGEN VON FEINSTEINZEUG IM AUSSENBEREICH**
Um einen Bodenbelag in Keramik im Außenbereich gut zu verlegen, müssen Fliesen höherer Qualität gewählt und verwendet werden. Ebenso wichtig ist ein erfahrener Konstrukteur, der die gesamte Verlegung an die besonderen Anforderungen und der statischen Situation der Oberfläche anpasst. Die Schichten des Unterbodens müssen auf entsprechende Belastungen ausgelegt werden, eventuell eine Betonstahlmatte einbauen, um mögliche Senkungen des Unterbodens zu vermeiden. Das Projekt der Derformationsfugen, Anwendungstechniken des Mörtelbetts und der Fliesen müssen unter Beachtung des TECHNISCHEN BERICHTS CEN/TR 13548 "Allgemeine Regeln für Projektgestaltung und Ausführung von Keramikfliesenbelägen" erfolgen. Nachfolgend einige Hinweise **für die Verlegung von Böden im Außenbereich Monocibec**:

- Verwendung von zementären Klebemörtel mit verlängerter Klebeoffener Zeit und Verformbarkeit (Klasse C2E S1 nach EN 12004) für Formate bis 25cmx25cm auf Zementestrich, Betonstrukturen und Abdichtungen
- Verwendung von zementären Klebemörtel mit verlängerter Klebeoffener Zeit und hoher Verformbarkeit (Klasse C2E S2 nach EN 12004) für größere Formate auf Zementestrich, Betonstrukturen und Abdichtungen
- Die Methode der doppelseitigen Beschichtung mit Hilfe eines Spachtels mit geeigneter Zahnung

anwenden, so das das Bett ausgefüllt ist: dadurch wird die Bildung von Leerräumen vermieden, in denen sich Wasser ansammelt und deren Volumen sich durch Frost vergrößert, wodurch sich die Fliese ablöst und den Bodenbelag beschädigt.

4) Fugen nicht unter 3 mm und Ausgleichsfugen (nicht unter 5 mm breit und mindestens alle 9-12 m2), um starken Spannungen durch nächtliche/saisonale Temperaturschwankungen, die sich zwischen Unterboden und Feinsteinzeug, das sich praktisch überhaupt nicht ausdehnt, entgegenzuwirken.
5) Im Projekt müssen regelmäßige Neigungen von mindestens 1,5% vorgesehen werden, so dass Flüssigkeiten leicht abfließen können. Diese müssen in der Struktur selbst ausgeführt werden oder es muss ein besonderer, geneigter Estrich vorgesehen werden. Bei einer traditionellen Verlegung mit Zementmörtel wird nicht empfohlen, eine Neigung durch die Veränderung der Dicke des Mörtelbetts zu erreichen.

**WASCHEN NACH DEM VERLEGEN**
Das Waschen nach dem Verlegen bei Abschluss des Bauvorhabens ist Pflicht. Werden Stuckreste, die zum Verfügen verwendet wurden, nicht richtig oder zu spät entfernt, dann können Ränder verbleiben, die schwer zu entfernen sind und auf dem Bodenbelag einen Zementfilm hinterlassen, an dem der Schmutz hängen bleibt und so den Eindruck hinterlässt, dass das Material leicht schmutzig wird.
a) Fugen mit Zementstück (Klasse CG – EN 13888): um ein Übermaß an Zementstück zu entfernen, den Boden mit einer Lösung Wasser + gepuffertes Säure waschen (Prozentsatz Wasser/Säure siehe Verpackung). Es wird empfohlen, folgende Produkte zu verwenden:

- Deterdek Pro - Fila
- Delta Plus - Kerakoll
- Ultracare Keranet - Mapei
- Ultracare Acid Cleaner - Mapei
- Cement Remover - Faber
- Solvacid - Geal Bel Chimica

b) Fugen mit Epoxidstück (Klasse RG - EN13888) (nicht für strukturierte oder geläppte/geschliffene Oberflächen empfohlen, es sei denn es wurden zuvor Versuche ausgeführt): es ist von fundamentaler Bedeutung, keine Epoxidreste nach den Arbeiten zu hinterlassen und das gesamte überschüssige Material von der Fliesenoberfläche zu entfernen, bevor es auszuhärten beginnt, da es sich danach äußerst schwierig entfernen lässt). Sollten dennoch Reste und Ränder des Epoxidstücks verbleiben, dann ein spezifisches Produkt verwenden und den Anweisungen des Herstellers folgen:
Es wird empfohlen, folgende Produkte zu verwenden:

- Fuga-Soap Eco - Kerakoll
- Ultracare Kerapoxy Cleaner - Mapei
- Epoxy Residue Remover - Faber Chimica
- CR10 - FILA
- Eposolv - Geal Bel Chimica

Für beide Stucktypen empfehlen wir, zuerst den groben Schmutz zu entfernen und die Reinigungsmittel, die nach den Angaben des Herstellers verdünnt werden, mit Hilfe eines farblosen Lappen auf den Fliesen scheuernd zu verteilen. Wir raten zur Probe eine Reinigung auf einer Oberfläche von wenigen Quadratmetern durchzuführen; ist das Ergebnis befriedigend, dann wird die Reinigung auf der gesamten Oberfläche ausgeführt. Dabei vermeiden, dass diese Reinigungsmittel mit Spezialteilen und Elementen aus Aluminium, Stahl und Naturstein (z.B. Marmor) in Kontakt geraten. Während der Wirkung des Reinigungsmittels (die Dauer wird vom Hersteller im Etikett angegeben), den hartnäckigen Schmutz mit Scotch-Brite Schwämmchen oder Zelluloseschwämmchen scheuern. Danach wird der Bodenbelag mit reichlich Wasser nachgespült, bis der Boden frei von Reinigungsrückständen und Schmutz ist. Geschliffenes/geläpptes Material, Spezialteile und dekorierte Teile von Stuckresten und Zementmörtel reinigen, bevor dieser antrocknet, denn es dürfen keine scheuernde Schwämme verwendet werden, die die wertvollen glänzenden Oberflächen verkratzen könnten.

Nach der Reinigung mit Säuren, könnte es notwendig sein, eine Reinigung mit basischen oder alkalinen, fettlösenden Mitteln durchzuführen. Eine Reinigung mit Säuren kann den Boden schmierig hinterlassen, wodurch Schmutz am Boden zurückgehalten wird. Wir empfehlen folgende Produkte als alkaline Reinigungsmittel zu verwenden:

- PS87 PRO - Fila
- Ultracare HD Cleaner - Mapei
- Wax remover - Faber Chimica
- Deterflash - Geal Bel Chimica

**ORDENTLICHE INSTANDHALTUNG UND TÄGLICHE REINIGUNG**
Nachdem die "Reinigung nach dem Verlegen" durchgeführt wurde, ist es für eine gute ordentliche Instandhaltung ausreichend, Keramikoberflächen Monocibec mit normalen neutralen Reinigungsmitteln für den Hausgebrauch, die in heißem Wasser verdünnt werden, zu putzen. Dabei immer den Herstellerangaben auf der Verpackung folgen. Den Boden immer sehr sorgfältig nachspülen und trocken, wodurch Schmutz entfernt und Ansammlungen von Kalkschichten, Reinigungsmitteln und Schmutzresten vermieden werden. Zu diesen Zweck empfehlen wir folgende Produkte:

- Fila Cleaner - Fila
- Ultracare Multicleaner - Mapei
- Tile Cleaner - Faber Chimica
- Bel Gres - Geal Bel Chimica

Die Verwendung von Bohnerwachs, öhaltigen Seifen, Imprägniermitteln und verschiedenen Behandlungen (gegen Öl und Wasser) auf Feinsteinzeug wird nicht empfohlen, da diese Anwendungen nicht nötig sind. Fluorwasserstoffsäure (Flusssäure - HF) und deren Derivate beschädigen irreparabel alle Keramikprodukte. Es ist daher äußerst wichtig zu prüfen, keine Produkte zu verwenden, die diese chemische Substanz enthalten (manchmal in Produkten für die außergewöhnliche Reinigung von Bädern, Duschen, etc. enthalten).

**AUSSERGEWÖHNLICHE REINIGUNG**
Bei besonderen Flecken oder/und besonders harträckigen Flecken oder bei einer außergewöhnlichen Reinigung des gesamten Bodenbelags, wird empfohlen, spezifische Reinigungsmittel zu verwenden. Diese werden in der folgenden Tabelle erläutert. Wir machen darauf aufmerksam, dass jeder Fleck sich leichter entfernen lässt, wenn dieser noch frisch ist. Bei geläpntem oder geschliffenem Feinsteinzeug ist es wichtig, vor der Verwendung von Reinigungsmitteln, immer einen Test auszuführen.

Fincibec ist Mitglied von 

# Index

The Company

Technology

Sizes

Thicknesses

Surfaces

Porcelain stoneware

Ecologycare

Certifications

Quality and Safety

Ceramic of Italy

Fincibec Group

Campus

Engineering

Pools &amp; Wellness

Facades

Raised Flooring

Technical Specifications

&gt;

&gt;

&gt;

&gt;

&gt;

&gt;

&gt;

&gt;

&gt;

&gt;

&gt;

&gt;

&gt;

&gt;

&gt;

&gt;

&gt;

&gt;

&gt;

&gt;

&gt;

&gt;

&gt;

&gt;

&gt;

&gt;

&gt;

&gt;

&gt;

&gt;

&gt;

&gt;

&gt;

&gt;

&gt;

&gt;

&gt;

&gt;

&gt;

&gt;

&gt;

&gt;

&gt;

&gt;

&gt;

&gt;

&gt;

&gt;

&gt;

&gt;

&gt;

&gt;

&gt;

&gt;

&gt;

&gt;

&gt;

&gt;

&gt;

&gt;

&gt;

&gt;

&gt;

&gt;

&gt;

&gt;

&gt;

# MANUAL DE USO: COLOCACIÓN, MANTENIMIENTO Y LIMPIEZA

COLOCACIÓN

COLOCACIÓN

La colocación del material. Antes de la colocación, es importante comprobar escrupulosamente el tono, el calibre y la elección del material, ya que no se aceptarán reclamaciones relativas a materiales ya colocados, cuyos defectos fuesen visibles antes de la colocación. Se aconseja realizar pedidos de material con excedente de 10 o 15 % en relación a la superficie a embaldosar en caso de que fuera necesario realizar reparaciones de distinta naturaleza, puesto que los pedidos sucesivos de baldosas podrían tener una tonalidad que no se combina perfectamente con aquella usada anteriormente.

Durante la colocación, aconsejamos extraer siempre el material de varias cajas, sobre todo si se trata de series con un nivel de variación cromática y de tonalidad superior a V = 2 (ref. catálogo general y por colección). Tanto para los productos veteados como para las piedras naturales, se recomienda colocar la veta de las losas de forma que se obtenga el mejor efecto estético y cromático posible.

La colocación puede realizarse ya sea mediante el espolvoreo de cemento, ya sea de cola, usando aglutinantes específicos de alto rendimiento para gres porcelánico. De todas formas, se aconseja la colocación con cola ya que ofrece una mayor garantía de adhesencia, especialmente en formatos grandes. En el momento de la colocación, el fondo debe estar plano, estable, seco y estabilizado, ni helado ni excesivamente caliente y, de cualquier forma, es necesario seguir las instrucciones de los fabricantes de los materiales para fondos y de los aglutinantes específicos empleados. Las colas de cemento deben aplicarse a una temperatura ambiente, generalmente comprendida entre los +5° C y + 30/35° C. Es evidente que también para la colocación, se aconseja respetar los tiempos técnicos indicados por los fabricantes de las colas empleadas. Las colas más adecuadas para la colación del gres porcelánico pueden identificarse consultando la Normativa Europea actualmente vigente EN12004. En particular, para productos esmerilados/pulidos, aunque también es una buena regla para el resto de productos, no debe marcarse la superficie del material con lápices o rotuladores indelebles durante las operaciones de colocación. Se aconseja emplear el doble encolado para baldosas con un lado de longitud mayor de 60 cm para conseguir una capa compacta de cola tal y como previsto en la norma sobre colocación UNI 11493.

**LAS JUNTAS Y EL REJUNTADO**

El ancho de la junta puede variar también en función del tamaño de las baldosas y del destino de uso del pavimento. Se desaconseja la colocación a matajuntas, en cambio se aconseja la colocación con una junta de 2 mm para el producto rectificado y de 3 mm como mínimo para el no rectificado o para la colocación de material para exterior (este tipo de colocación facilita la adherencia del sellador en los lados de las baldosas y una mayor absorción y compensación de los eventuales movimientos del fondo). En los ambientes grandes, se aconseja colocar con regularidad juntas de dilatación; en cambio en los espacios más reducidos, basta con dejar una ligera separación entre el material y las paredes perimetrales. Después, el hueco se cubrirá con el zócalo dando un aspecto de acabado. Remítase en cualquier caso a los consejos/ sugerencias del proyectista o encargado de la obra.

En caso de elegir la colocación “en sentido longitudinal” de los productos con formatos rectangulares, se aconseja desplazar el lado más largo unos 10-15 cm como máximo con respecto a la longitud de la pieza adyacente. Para los formatos grandes (según previsto en la norma UNI 11493) se aconseja utilizar la técnica del doble encolado: la cola debe aplicarse tanto en el reverso de la baldosa como en la pared/suelo, a fin de evitar la presencia de huecos entre la cerámica y el soporte. Durante la colocación de los productos es conveniente recubrir el suelo con telas y cartones durante la fase de colocación, a fin de evitar que materiales residuales puedan rayar la superficie de las baldosas.

Para aumentar el valor estético, recomendamos materiales de rejuntado que entonen con el color de la baldosa para reducir el contraste, sobre todo en productos esmerilados o rectificados. Tras el rejuntado de las baldosas de gres porcelánico, cuando el material de rejuntado aún esté fresco, es importante eliminar inmediata y cuidadosamente el exceso de material de rejuntado con una esponja y abundante agua.

**COLOCACIÓN SOBRE SUELOS PREEXISTENTES**

- Antes de realizar la colocación, comprobar la planitud de las superficies y, de ser necesario, nivelarlas. En cualquier caso, las superficies deben ser limpiadas para eliminar los posibles rastros de ceras, aceites o residuos que pueden perjudicar la adhesencia.
- Prever juntas de 2 mm y juntas de dilatación perimetrales. Respetar las juntas de dilatación que están debajo.
- Extender la cola sobre el suelo de fondo con una espátula adecuada y también sobre la losa que va a colocarse con la parte lisa de la espátula, siguiendo el método del doble encolado.
- En algunos casos puede ser útil aplicar otra capa de cola en aristas y cantos.
- Colocar la losa y eliminar los huecos de aire golpeando con cuidado la superficie para conseguir una completa adheserencia y evitando que las juntas se impregnen de pegamento.

**COLOCACIÓN DE REVESTIMIENTOS DE PAREDES**

Se requieren las mismas operaciones realizadas para colocar una baldosa de gres porcelánico:

- Comprobar la planitud de las superficies, nivelándolas si fuese necesario.
- Prever juntas de al menos 2 mm. Respetar las justas de dilatación del fondo.
- Extender la cola sobre la pared utilizando una espátula adecuada.
- Colocar la losa y eliminar los huecos de aire golpeando con cuidado la superficie para conseguir una adheserencia completa.

Utilizar como cola aglutinantes para gres porcelánico eligiendo el tipo más adecuado a las características de la pared a revestir. En el exterior, cabe prever un correcto dimensionamiento de las juntas y una adecuada red de juntas elásticas en función del fondo, las dimensiones y la planimetría de la fachada.

**COLOCACIÓN DE GRES PORCELÁNICO EN EL EXTERIOR**

Para conseguir una perfecta pavimentación en cerámica de superficies externas, es tan indispensable elegir y utilizar baldosas de calidad superior, como la presencia de un proyectista experto que pueda adecuar, en su conjunto, el sistema de colocación a las cargas específicas necesarias y a la situación estática de la superficie sobre la que se va a intervenir. En particular, los estratos de fondo deben dimensionarse en función de dichas cargas teniendo en cuenta la posibilidad de usar redes electrosoldadas para prevenir eventuales asentamientos de los estratos de fondo. El proyecto de las juntas de dilatación y las técnicas de aplicación del mortero y de las baldosas deben realizarse respetando el INFORME TÉCNICO CEN/TR 13548 “Reglas generales para el diseño y la instalación de baldosas cerámicas”. Seguidamente algunas indicaciones **para la colocación de pavimentos en el exterior Naxos**:

1) Utilización de cola de cemento mejorada, deformable, con tiempo abierto prolongado, (de clase C2E S1 según la EN 12004) para formatos de hasta 5cmx25cm en morteros de cemento, estructuras en colada de hormigón e impermeabilizaciones.
2) Utilización de cola de cemento mejorada deformable, con tiempo abierto prolongado, (de clase C2E S2 según la EN 12004) para baldosas de tamaño de formatos superiores en morteros de cemento, estructuras en colada de hormigón e impermeabilizaciones.

3) Emplear la técnica del doble encolado mediante una espátula dentada adecuada para conseguir una capa llena: lo que permite evitar que se formen vacíos que causan el estancamiento de agua, con el riesgo de un aumento del volumen debido al hielo y, por consiguiente, la separación o rotura del pavimento.

4) Utilización de juntas no inferiores a los 3 mm y realización de juntas de dilatación (con ancho no inferior a 5 mm y realizadas al menos cada 9-12 m2) para hacer frente a los fuertes estados de tensión debidos a la variación térmica diurna/de estación que se producen entre el gres porcelánico, que cuenta con un coeficiente de dilatación prácticamente nulo, y el soporte.

5) Las pendientes de proyecto deben ser regulares y, al menos, del 1,5% para facilitar el flujo de los líquidos. Deben realizarse en la misma estructura, o bien preparando un mortero especial en pendiente; en el caso de colocaciones tradicionales con mortero de cemento, se desaconseja realizar la pendiente modificando el espesor del mortero.

**EL LAVADO “POSColocación”**

Tras las operaciones de colocación, es obligatorio proceder al lavado al finalizar la obra. Una eliminación inadecuada o tardía de los residuos del rejuntado utilizado para las juntas, puede dejar cercos difíciles de quitar y crear en el pavimento una película de cemento que puede absorber la suciedad dando la impresión de que es el material el que se ensucia.

a) Juntas con rejuntado de cemento (Clase CG – EN 13888): para eliminar el exceso del material de rejuntado de cemento, debe lavarse el suelo con una solución de agua + ácido taponado (utilizando los porcentajes de agua /ácido indicados en el envase).

Se recomienda utilizar los siguientes productos:

- Detardek Pro - Fila
- Delta Plus - Kerakoll
- Ultracare Keranet - Mapei
- Ultracare Acid Cleaner - Mapei
- Cement Remover - Faber
- Solvacid - Geal Bel Chimica

b) Juntas con masilla epoxi (Clase RG –EN13888) (se desaconseja el uso para superficies estructuradas o esmeriladas/pulidas antes de haber realizado la prueba en la obra): es muy importante no dejar residuos de material epoxi, una vez finalizado el trabajo, deberá ser eliminado el material en exceso sobre la superficie de la baldosa antes de que empiece a endurecerse puesto que su eliminación sería mucho más difícil. En caso de que haya residuos y cercos de masilla epoxi, utilice un producto específico siguiendo las instrucciones del fabricante:

Se recomienda utilizar los siguientes productos:

- Fuga-Soap Eco - Kerakoll
- Ultracare Kerapoxy Cleaner - Mapei
- Epoxy Residue Remover - Faber Chimica
- CR10 - FILA
- Eposolv - Geal Bel Chimica

Para ambos tipos de masilla, recomendamos ante todo eliminar de modo aproximado la suciedad y aplicar frotando con un paño incoloro, los detergentes sobre las baldosas, diluidos según las indicaciones del fabricante. Recomendamos efectuar un lavado previo sobre la superficie muestra de unos metros cuadrados; en caso de resultado positivo, limpiar toda la superficie, evitando que los detergentes entren en contacto con las piezas especiales y los elementos de aluminio, acero, piedras naturales (p.ej. mármol). Durante el tiempo de acción de los detergentes (establecidos por el fabricante que aparecen en la etiqueta) eliminar la suciedad más recaicitrante con taponés Scotch-Brite o bien con una esponja de celulosa. Sucesivamente es preciso realizar el aclarado con agua abundante del pavimento para asegurarse de que el pavimento no tenga residuos de detergentes ni suciedad. Para los materiales esmerilados/pulidos y piezas especiales/decoraciones es preciso eliminar ante todo los residuos de masilla y mortero de cemento antes de que estos materiales se sequen, evitando así el empleo de esponjas abrasivas que podrían rayar las preciadias superficies brillantes.

Una vez realizado el lavado ácido, podría ser necesario realizar un lavado básico o alcalino utilizando detergentes desengrasantes. Puesto que el lavado ácido puede dejar grasa en el suelo que podría favorecer la retención de suciedad. Como de tergergente alcalino, se aconseja utilizar los productos siguientes:

- PS87 PRO - Fila
- Ultracare HD Cleaner - Mapei
- Wax remover - Faber Chimica
- Deterflash - Geal Bel Chimica

**MANTENIMIENTO ORDINARIO Y LIMPIEZA DIARIA**

Tras haber realizado la limpieza “poscolocación” (capítulo anterior), para un buen mantenimiento ordinario de las superficies cerámicas Naxos basta limpiarlas con detergentes neutros comunes diluidos en agua caliente, siguiendo en todo momento las indicaciones presentes en los envases. Se aconseja prestar especial atención a las fases de aclarado y secado del suelo, ya que permiten eliminar la suciedad y evitar la acumulación (estratificación) de cal, del detergente y residuos de suciedad. Para este propósito, aconsejamos los siguientes productos:

- Fila Cleaner - Fila

- Ultracare Multicleaner - Mapei

- Tile Cleaner - Faber Chimica

- Bel Gres - Geal Bel Chimica

Se desaconseja encarecidamente el uso de ceras, jabones oleosos, agentes de impregnación y otros tratamientos (hidro-óleo repelentes) sobre el producto de gres porcelánico, pues su aplicación no es en absoluto necesaria.

El el ácido fluorhídrico (HF) y sus derivados pueden estropear irremediablemente todos los productos de cerámica, por lo tanto es importante asegurarse de que los productos que se utilizan no contienen estas sustancias químicas (tal vez contenidos en algunos productos para la limpieza extraordinaria de cuartos de baño, superficies de ducha, etc)

**LIMPIEZA EXTRAORDINARIA**

En el caso de manchas particulares y/o muy resistentes, o para una limpieza extraordinaria de toda la pavimentación, es aconsejable el uso de detergentes específicos, como se indica en la tabla propuesta a continuación. Cabe asimismo señalar que la eliminación de cualquier tipo de mancha es más fácil si se realiza cuando aún está reciente. En particular, con gres porcelánico esmerilado o pulido, es importante efectuar siempre una prueba preventiva antes de usar los productos detergentes.

Fincibec es socio de 

★ ★ ★ ★ ★

**MONOCIBEC®**

FINCIBEC GROUP

## EXTRAORDINARY CLEANING - PULIZIA STRAORDINARIA NETTOYAGE EXTRAORDINAIRE - AUSSERORDENTLICHE REINIGUNG - LIMPIEZA EXTRAORDINARIA

<b>TYPE OF STAIN</b> TIPO DI MACCHIA TYPE DE TACHE ART DES FLECKS TIPO DE MANCHA	Detergents* / Detergenti / Détergents / Reinigungsmittel / Detergentes		<b>Solvents *</b> Solventi Solvants Lösungsmittel Disolvente
	<b>Degreasers / Cleaners alkaline</b> Sgrassatori / pulitori alcalini Dégraissants / Nettoyants alcalins Fettlösende Mittel / Alkalische Reiniger Desengrasantes / Limpiadores alcalinos	<b>Limescale removers acid</b> Decalcarizzanti acidi Détartrants acides Kalklösend Säuren Descalcificadores ácidos	
<b>Olio e grasso</b> / Oil / Huile / Ôle / Aceite <b>Grasso</b> / Grease / Graisse / Fett / Grasa <b>Birra</b> / Beer / Bière / Bier / Cerveza <b>Aceto</b> / Vinegar / Vinaigre / Essig / Vinagre <b>Succo di frutta</b> / Fruit juice / Jus de fruit / Obstsaft / Zumo de fruta <b>Salse</b> / Sauces / Sauces / Soßen / Salsas <b>Macchie di verdura</b> / Vegetable stains / Tache de légumes / Gemüselacke / Manchas de verduras <b>Thè</b> / Tea / Thé / Tee / Té <b>Residui organici</b> / Organic residues / Résidus organiques / Organische Reste / Resíduos orgánicos <b>Gomma di scarpe</b> / Shoe rubber / Caoutchouc de chaussures / Gummisohlen / Goma de zapatos <b>Cere di trattamento</b> / Treatment wax / Cire de traitement / Pflegemittel auf Wachsbasis / Cera de tratamiento	ULTRACARE HD CLEANER (MAPEI) PS87 PRO (FILA) DEEP DEGREASER (FABER CHIMICA) DETERFLASH (GEAL - Bel CHIMICA)	ULTRACARE MULTICLEANER (MAPEI) ULTRACARE MULTICLEANER SPRAY (MAPEI)	
<b>Ketchup</b>	ULTRACARE HD CLEANER (MAPEI) PS87 PRO (FILA) DEEP DEGREASER (FABER CHIMICA) DETERFLASH (GEAL - Bel CHIMICA)	ULTRACARE MULTICLEANER (MAPEI) ULTRACARE MULTICLEANER SPRAY (MAPEI) TILE CLEANER (FABER CHIMICA)	
<b>Gelato</b> / Ice cream / Glace / Eis / Helado	ULTRACARE HD CLEANER (MAPEI) PS87 PRO (FILA) DEEP DEGREASER (FABER CHIMICA) DETERFLASH (GEAL - Bel CHIMICA)	ULTRACARE MULTICLEANER (MAPEI) ULTRACARE MULTICLEANER SPRAY (MAPEI) TILE CLEANER (FABER CHIMICA)	
<b>Caffè</b> / Coffee / Café / Kaffee / Café	ULTRACARE HD CLEANER (MAPEI) PS87 PRO - SR 95 (FILA) COLOURED STAIN REMOVER (FABER CHIMICA) DETERFLASH (GEAL - Bel CHIMICA)	ULTRACARE MULTICLEANER (MAPEI) ULTRACARE MULTICLEANER SPRAY (MAPEI) SOLVACID (GEAL - Bel CHIMICA) TILE CLEANER (FABER CHIMICA)	
<b>Vino</b> / Wine / Vin / Wein / Vino <b>Coca cola</b> / Coke / Coca-Cola / Cola / Coca-cola	ULTRACARE HD CLEANER (MAPEI) PS87 PRO - SR 95 (FILA) COLOURED STAIN REMOVER (FABER CHIMICA) DETERFLASH (GEAL - Bel CHIMICA)	ULTRACARE MULTICLEANER (MAPEI) ULTRACARE MULTICLEANER SPRAY (MAPEI) TILE CLEANER (FABER CHIMICA)	
<b>Chewing gum</b> / Chewing gum / Chewing gum Kaugummi / Chiclé	ULTRACARE HD CLEANER (MAPEI) PS87 PRO (FILA) DEEP DEGREASER (FABER CHIMICA) DETERFLASH (GEAL - Bel CHIMICA)	ULTRACARE MULTICLEANER (MAPEI) ULTRACARE MULTICLEANER SPRAY (MAPEI) TILE CLEANER (FABER CHIMICA)	SOLVENT STRIPPER (FABER CHIMICA)
<b>Nicotina</b> / Nicotine / Nicotine / Nikotin / Nicotina <b>Urina-vomito</b> / Urine-vomit / Urine-vomissure Urin-Erbrochenes / Órina-vómito	ULTRACARE HD CLEANER (MAPEI) PS87 PRO - SR 95 (FILA) COLOURED STAIN REMOVER (FABER CHIMICA) DETERFLASH (GEAL - Bel CHIMICA)	ULTRACARE MULTICLEANER (MAPEI) ULTRACARE MULTICLEANER SPRAY (MAPEI) TILE CLEANER (FABER CHIMICA) SOLVACID (GEAL - Bel CHIMICA)	
<b>Pneumatico</b> / Pnematic / Pneumatique Reifen / Neumático	ULTRACARE HD CLEANER (MAPEI) PS87 PRO (FILA) DEEP DEGREASER (FABER CHIMICA) DETERFLASH (GEAL - Bel CHIMICA)	ULTRACARE MULTICLEANER (MAPEI) ULTRACARE MULTICLEANER SPRAY (MAPEI)	
<b>Tintura per capelli</b> / Hair dye / Coloration pour cheveux / Haarfärbemittel / Tinte para el cabello	ULTRACARE HD CLEANER (MAPEI) PS87 PRO - SR 95 (FILA) COLOURED STAIN REMOVER (FABER CHIMICA) DETERFLASH (GEAL - Bel CHIMICA)	ULTRACARE HD MULTICLEANER (MAPEI) TILE CLEANER (FABER CHIMICA) MULTICLEANER SPRAY (MAPEI)	
<b>Vernice</b> / Paint / Peinture / Lack / Barniz <b>Resine</b> / Resins / Résines / Harz / Resinas <b>Smalti</b> / Enamels / Vernis / Nagellack / Esmaltes <b>Pittura al quarzo</b> / Quartz paints / Peintures au quartz / Quarzfarben / Pinturas al cuarzo <b>Tempere contenenti resine</b> / Watercolours containing resins / Gouaches contenant des résines / Temperafarben mit Harzen / Temperas con resinas	ULTRACARE HD CLEANER (MAPEI) ULTRACARE EPOXY OFF GEL (MAPEI) PS87 PRO - NO PAINT STAR (FILA) EPOXY CLEANER (FABER CHIMICA)	SOLVACID (GEAL - Bel CHIMICA)	PULICOL 2000 (MAPEI) SOLVENT STRIPPER (FABER CHIMICA)
<b>Colla</b> / Glue / Colla / Klebstoff / Pegamento	ULTRACARE HD CLEANER (MAPEI) ULTRACARE EPOXY OFF GEL (MAPEI) PS87 PRO - NO PAINT STAR (FILA) EPOXY CLEANER (FABER CHIMICA)	SOLVACID (GEAL - Bel CHIMICA)	
<b>Residui stucco CG (cemento con polimeri)</b> / Cement residues CG (with polymers) / Résidus de mortier CG (à base de ciment avec polymères) / Stuckreste CG (Zement mit Polymeren) / Residuos de masilla CG (de cemento con polímeros)		SOLVACID (GEAL - Bel CHIMICA) CEMENT REMOVER (FABER CHIMICA) DETERDEK PRO (FILA) ULTRACARE KERANET (MAPEI) ULTRACARE ACID CLEANER (MAPEI) ULTRACARE KERANET EASY (MAPEI)	
<b>Residui stucco RG (epossidico)</b> / Cement residues RG (epoxy) / Résidus de mortier RG (époxy) / Stuckreste RG (Epoxid) / Residuos de masilla RG (epoxidico)	ULTRACARE KERAPOXY CLEANER (MAPEI) ULTRACARE EPOXY OFF GEL (MAPEI) CR10 (FILA) EPOXY CLEANER (FABER CHIMICA)	EPOSOLV (GEAL - Bel CHIMICA)	
<b>Inchiostro</b> / Ink / Encre / Tinte / Tinta <b>Pennarello</b> / Felt-tip pen / Feutre / Filzstift / Rotulador	PS87 PRO - SR 95 (FILA) COLOURED STAIN REMOVER (FABER CHIMICA)	SOLVACID (GEAL - Bel CHIMICA)	
<b>Graffiti</b> / Graffiti / Graffiti / Graffiti / Pintadas	WALLGARD GRAFFITI REMOVER GEL (MAPEI) ULTRACARE HD CLEANER (MAPEI) ULTRACARE EPOXY OFF GEL (MAPEI) NOPAINT STAR (FILA) EPOXY CLEANER (FABER CHIMICA)	SOLVACID (GEAL - Bel CHIMICA)	GRAFFITI REMOVER (FABER CHIMICA) PULICOL 2000 (MAPEI)
<b>Residui di nastro adesivo</b> / Tape residue Résidus de ruban adhésif / Rückstände von Klebstreifen Residuos de cinta adhesiva	PS87 PRO - ZERO SIL (FILA) DEEP DEGREASER (FABER CHIMICA)	SOLVACID (GEAL - Bel CHIMICA)	ZEROSIL (FILA) SOLVENT STRIPPER (FABER CHIMICA)
<b>Bitume</b> / Bitumen / Bitume / Bitumen / Betún <b>Cera di candela</b> / Candle wax / Cire de bougie / Kerzenwachs / Cera de vela	ULTRACARE HD CLEANER (MAPEI) ULTRACARE EPOXY OFF GEL (MAPEI) DETERFLASH (GEAL - Bel CHIMICA) DEEP DEGREASER (FABER CHIMICA)		ZEROSIL (FILA) SOLVENT STRIPPER (FABER CHIMICA)
<b>Cemento-salnitro</b> / Cement-saltpeter / Ciment-salpêtre Zement-Salpeter / Cimento-salitre <b>Calcare</b> / Lime / Calcaire / Kalk / Cal <b>Tempere a base di calce (senza leganti sintetici)</b> / Lime-based watercolours (without synthetic binders) / Peintures à base de chaux (sans liants synthétiques) / Temperafarbe auf Kalkbasis (ohne syntetische Bindemittel) / Pinturas a base de cal (sin ligantes sintéticos)		DIETERDEK PRO (FILA) CERAMIK (GEAL - Bel CHIMICA) CEMENT REMOVER (FABER CHIMICA) ULTRACARE KERANET (MAPEI) ULTRACARE ACID CLEANER (MAPEI) ULTRACARE KERANET CRYSTALS (MAPEI)	
<b>Ruggine</b> / Rust / Rouille / Rost / Herrumbre <b>Segni metallici</b> / Metallic marks / Signes métalliques Metalspuren / Señales metálicas		DIETERDEK PRO - NORUST (FILA) CERAMIK (GEAL Bel CHIMICA) ULTRACARE ACID CLEANER (MAPEI) RUGGINE - CEMENT REMOVER SEGGNI METALLICI - TILE CLEANER (FABER CHIMICA)	
<b>Ingrignimento generale</b> / General greying / Effet de grisaille ou jaunissement général / Allgemeines Vergrauen / Agrisamiento general <b>Orme o polvere da calcpestio</b> / Footprints and Dust from football / Empreintes et poussières de piétinement / Spuren und Staub durch Auftreten / Huellas y polvo de pisada		DIETERDEK PRO (FILA) SOLVACID (GEAL - Bel CHIMICA) TILE CLEANER (FABER CHIMICA) ULTRACARE KERANET (MAPEI) ULTRACARE ACID CLEANER (MAPEI) ULTRACARE KERANET EASY (MAPEI)	
<b>Fuga sporca</b> / Dirt joint / Fuite polluante Schmutzige Fuge / Junta sucia	ULTRACARE GROUT CLEANER (MAPEI) FUGANET (FILA) FUGAPULITA (GEAL) GROUT CLEANER GROUT CLEANER (FABER CHIMICA)	TILE CLEANER (FABER CHIMICA)	

**\* Seguire le indicazioni del fabbricante, fare sempre test preventivo su una piastrella prima dell'uso e prestare particolare attenzione su materiali lappati e levigati e decori** / Follow the manufacturer's instructions, always pre-test on a tile before use and pay particular attention to lapped, polished and decorated materials / Suivre les indications du fabricant; toujours faire un test préalable sur un carreau avant l'utilisation et faire particulièrement attention aux matériaux polis et lissés et décorés / Den Angaben des Herstellers folgen. Vor Gebrauch das Produkt immer auf einer Fliese testen und bei glapptem und geschliffenen Material oder Verzierungen besonders vorsichtig sein / Siga las indicaciones del fabricante, realice siempre una prueba previa sobre la baldosa antes del uso y preste especial atención al aplicar el producto sobre materiales esmerilados y pulidos y decoraciones / Per aggiornamenti e revisioni fare riferimento all'area tecnica del sito WEB: WWW.CENTURY-CERAMICA.IT / For updates and revisions please refer to the technical area of the Website: WWW.CENTURY-CERAMICA.IT / Pour toute mise à jour et révision, consulter la zone technique du site Internet : WWW.CENTURY-CERAMICA.IT / Schauen Sie nach Neuarbeitungen und Überarbeitungen im technischen Bereich auf der Website: WWW.CENTURY-CERAMICA.IT / Para más información sobre las actualizaciones y las revisiones, consulte el área técnica del sitio WEB: WWW.CENTURY-CERAMICA.IT / per ulteriori informazioni/charimenti contattare l'ufficio assistenza qualità Naxos all'indirizzo: quality@fincibec.it / for further information / clarification contact Naxos quality assurance at: quality@fincibec.it / pour toute information ou tout renseignement complémentaire, contactez le service assurance qualité Naxos a l'adresse : quality@fincibec.it / für weitere informationen/verläuterungen setzen sie bitte schrift mit der abteilung qualitätssicherung Naxos unter folgender anschrift in verbindung: quality@fincibec.it / para más información o aclaraciones que precise, contacte con la oficina de garantía de calidad Naxos en la siguiente dirección: quality@fincibec.it

# Index

The Company

Technology

Sizes

Thicknesses

Surfaces

Porcelain stoneware

Ecologycare

Certifications

Quality and Safety

Ceramic of Italy

Fincibec Group

Campus

Engineering

Pools & Wellness

Facades

Raised Flooring

Technical Specifications

## Contents by collection

Archè	Geobrick
Ashley	Graphis
Azimuth	On Stage
Blade	Pietra Castello
Charisma	Pietre Naturali
Dicta	Tradition
Dolomite	Transalp
Esprit	Woodtime
Evolution	Yukon
Gamut	Major

## Contents by effect

WOOD - Legno
MARBLE - Marmo
STONE - Pietra
CONCRETE - Cemento

## Color Index

Color Index Major 20mm

# GENERAL SELLING CONDITIONS FINCIBEC S.P.A.

Headquarter in Sassuolo

## 1. Introduction

1.1 These General Conditions shall govern, except as otherwise specifically agreed in writing, all present and future contracts of sale between the parties. General conditions of the Buyer will only apply to the extent they have been expressly accepted in writing: they must in any case be coordinated with these General Conditions.

1.2 The contract of sale is governed by the United Nations Convention on the International Sales of Goods (Vienna 1980) and, with respect to questions not covered by such Convention by the laws of Italy.

## 2. Characteristics of the products

2.1 Except as otherwise agreed in writing, the Seller does not warrant uniformity and/or conformity to possible samples with respect to the colour, tone or shade of the Products. Furthermore, the Seller does not warrant that the Products are fit for any particular use, except within the limits of the indications con tai ned in the Seller’s technical schedule regarding the respective Product.

2.2 Possible differences remaining within the tolerances which are usual in the industry and /or normally accepted in the relations between the parties, shall be considered as conforming to the Contract.

2.3 The Seller warrants that the Products conform to the technical specifications in force in Italy. Possible requirements in force in the country of destination may be taken into consideration, provided this has been requested in advance in writing by the Buyer, specifying the requirements to be observed.

## 3. Time of delivery

3.1 All delivery terms possibly agreed between the parties are deemed to be estimates only. However, if a delay for which the Seller is responsible exceeds 90 days, the Buyer will be entitled to terminate the Contract with reference to the Products the delivery of which is delayed, Any delay caused by force majeure (as defined in art. 9) shall not be considered as a delay for which the Seller is responsible.

3.2 Except in case of fraud or gross negligence, any compensation for damages arising out of non-delivery or delayed delivery of the Products is expressly excluded.

## 4. Delivery and shipment - Complaints

4.1 Except as otherwise agreed, the supply of the goods will be Ex Works (EXW), Incoterms 2010, even if it is agreed that the Seller will take care, in whole or in part, of the shipment.

4.2 In any case, whatever the delivery terms agreed between the parties, it is expressly agreed that delivery occurs when the Products are handed over to the first carrier at the Seller’s factory. The risks will pass to the Buyer, at the latest, on delivery of the goods to the first carrier.

4.3 Any complaints relating to packing, quantity, number or exterior features of the Products (apparent defects), must be notified to the Seller, by registered letter with return receipt, within 8 days from receipt of the Products; failing such notification the Purchaser’s right to claim the above defects will be forfeited. Any complaints relating to defects which cannot be discovered on the basis of a careful inspection upon receipt (hidden defects) must be notified to the Seller, by registered letter with return receipt, within 8 days from discovery of the defects and in any case not later than three months from delivery; failing such notification the Purchaser’s right to claim the above defects will be forfeited.

4.4 Any complaint under art. 4.3 must specify in writing the reasons of the complaint and the Products affected. If the Buyer claims the Products to be defective, he must send to the Seller – when he notifies the complaint – such samples of the defective goods as are necessary to verify the defect, unless otherwise agreed in writing.

4.5 It is agreed that any complaints or objections do not entitle the Buyer to suspend or to delay payment of the Products as well as payment of any other supplies.

It is agreed that, the Products delivered remain the Seller’s property until complete payment is received by the latter.

Unless otherwise agreed, prices are those of the Seller’s price list in force when the order is received. The price is intended for delivery Ex Works (EXW), Products including normal packing, it being under stood that any other cost or charge shall be for the account of the Buyer. All prices are intended net of VAT, possible taxes and levies as well as any fiscal or other kind of duty or burden which the Contract may be subject to.

## 5. Retention of title

## 6. Prices

## 7. Payment conditions

7.1 Payment must be made at the agreed conditions (time, currency). Payment is deemed to be made when the respective sum is at the Seller’s disposal at its bank in Italy. Unless otherwise agreed, any expenses or bank commissions due with respect to the payment shall be for the Buyer’s account.

7.2 Should payment be delayed with respect to the agreed date, the Buyer shall pay to the Seller interest for late payment at a rate corresponding to the interest rate applied by the European Central Bank to its main refinancing operations plus seven percentage points, in conformity with Article 4 of decree n. 231 of 9 October 2002 which implements the EC Directive 35/2000. Should the delay exceed 30 days from the date indicated in the invoice, the Seller will be entitled to terminate the contract, to retain the part of the price already paid and to claim the return, at the Buyer’s expense, of the products delivered, plus possible damages

7.3 Should the Seller have reasons to fear that the Buyer cannot or does not intend to pay the Products on the agreed date, he may make delivery dependant on obtaining an appropriate payment guarantee (e.g. surety or bank guarantee). Furthermore the Seller may, in case of delayed payment, unilaterally modify the terms of payment of other supplies and/or suspend their performance until he obtains appropriate payment guarantees.

## 8. Warranty for defects

8.1 The Seller undertakes to remedy any non-conformity of the Products for which he is liable, occurring within one year from delivery of the Products, provided such defects have been timely notified in accordance with art. 4.3, by supplying Products replacing the Products which have shown to be defective.

8.2 Except in case of fraud or gross negligence of the Seller, the Seller’s only obligation in case of non-conformity of the Products will be that of supplying replacement Products, as foreseen under article 8.1 hereabove. It is agreed that the above mentioned guarantee is in lieu of any other legal guarantee or liability with the exclusion of any other Seller’s liability (whether contractual or non-contractual) which may anyhow arise out of or in relation with the Products supplied (e.g. compensation of damages, loss of profit, removal of the defective Products, etc.).

8.3 The guarantee isn’t applied to lower grade material and with respect to blatant defects and/or faults (such as defected of shape, size, thickness, grade and colour, ect.) the guarantee shall not apply when the material has already been installed.

8.4 With respect to possible consumer claims involving the application of domestic rules implementing the European directive 1999/44/CE of 25 May 1999 on certain aspects of the sale of consumer goods and associated guarantees, the Buyer accepts to bear the exclusive responsibility for any obligation arising within such context. Consequently the parties expressly agree to exclude any right of redress by the Buyer against the Seller based on the above Directive and the Buyer undertakes to hold the Seller harmless against any such action of redress made by subse quent sellers of the distribution chain. The competent law courts of Modena (Italy) shall have exclusive jurisdiction in any action arising out of or in connection with this contract. How ever, as an exception to the principle hereabove, the Seller is in any case entitled to bring his action before the competent court of the Buyer’s place of business.

## 9. Jurisdiction

# CONDIZIONI GENERALI DI VENDITA DI FINCIBEC S.P.A.

Con sede in Sassuolo

## 1. Premessa

1.1 Le presenti Condizioni Generali, salvo eventuali deroghe specificatamente concordate per iscritto, disciplinano tutti gli attuali e futuri contratti di vendita tra le parti. Eventuali condizioni generali del Compratore non troveranno applicazione se non espressamente accettate per iscritto e dovranno comunque venir coordinate con le presenti Condizioni Generali.

1.2 Il contratto di vendita è disciplinato dalla Convenzione delle Nazioni Unite sulla vendita internazionale di merci (Vienna 1980) e, per le questioni non coperte da tale convenzione, dalla legge italiana.

## 2. Caratteristiche dei prodotti

2.1 Salvo che sia diversamente pattuito per iscritto, il Venditore non garantisce la uniformità e/o la conformità ad eventuali campioni per quanto riguarda il colore, tonalità o sfumatura di colore dei Prodotti. Inoltre, il Venditore non garantisce che i prodotti siano adatti ad un uso particolare, eccetto che nei limiti di quanto indicato nella scheda tecnica del Venditore del relativo Prodotto.

2.2 Eventuali differenze qualitative entro i margini di tolleranza usuali nel settore e/o normalmente accettati nei rapporti tra le parti saranno considerate conformi al Contratto.

2.3 Il Venditore garantisce la conformità dei Prodotti alle prescrizioni tecniche vigenti in Italia. Eventuali requisiti richiesti nel paese di destinazione potranno essere prese in considerazione solo su previa richiesta scritta del Compratore, che dovrà precisare il contenuto delle prescrizioni da osservare.

## 3. Termini di consegna

3.1 I termini di consegna eventualmente concordati dalle parti hanno natura meramente indicativa. Tutta via, in presenza di un ritardo imputabile al Venditore che superi i 90 giorni, il Compratore potrà risolvere il Contratto relativamente ai Prodotti di cui la consegna è ritardata. Non si considera imputabile al Venditore l’eventuale ritardo dovuto a cause di forza maggiore (come definite all’art. 9).

3.2 Salvo il caso di dolo o colpa grave del Venditore, è espressamente escluso qualsiasi ulteriore risarcimento del danno per mancata o ritardata consegna dei Prodotti.

## 4. Resa e spedizione - Reclami

4.1 Salvo patto contrario, la fornitura della merce d’intende Franco Fabbrica (EXW), Incoterms 2010, e ciò anche quando sia convenuto che la spedizione o parte di essa venga curata dal Venditore.

4.2 In ogni modo, quali che siano i termini di resa pattuiti dalle parti, si conviene espressamente che la consegna avviene con la consegna dei prodotti al primo trasportatore presso lo stabilimento del Venditore. I rischi passano al Compratore al più tardi con la consegna al primo trasportatore.

4.3 Eventuali reclami relativi allo stato dell’imballo, quantità, numero o caratteristiche esteriori dei Prodotti (vizi apparenti), dovranno essere notificati al Venditore mediante lettera raccomandata RR, entro 8 giorni dalla data di ricevimento dei Prodotti; in assenza di tale notificazione, il Compratore decadrà dal diritto di contestare i vizi sopra indicati.

Eventuali reclami relativi a difetti non individuabili mediante un diligente controllo al momento del ricevimento (vizi occulti) dovranno essere notificati al Venditore mediante lettera raccomandata RR, entro 8 giorni dalla data della scoperta del difetto e comunque non oltre tre mesi dalla consegna; in assenza di tale notificazione, il Compratore decadrà dal diritto di contestare i vizi sopra indicati.

4.4 Qualsiasi reclamo di cui all’art. 4.3 deve specificare per iscritto le ragioni del reclamo ed i Prodotti cui si riferisce. Ove il Compratore faccia valere dei difetti dei Prodotti, egli deve inviare al Venditore – quando notifica il reclamo – campioni dei Prodotti difettosi nella misura necessaria per consentire di verificare il difetto, salvo diverso accordo scritto.

4.5 E’ inteso che eventuali reclami o contestazioni non danno diritto al Compratore di sospendere o comunque ritardare i pagamenti dei Prodotti oggetto di contestazione, né, tanto meno, di altre forniture.

E’ convenuto che i Prodotti consegnati restano di proprietà del Venditore fino a quando non sia pervenuto a quest’ultimo il completo pagamento. Salvo patto contrario, il prezzo dei Prodotti sarà quello del listino del Venditore in vigore al momento del ricevimento dell’ordine. Il prezzo si intende per resa Franco Fabbrica (EXW) compreso imballaggio normale, essendo inteso che qualsiasi altra spesa o onere sarà a carico del Compratore. I prezzi si intendono al netto dell’IVA, di eventuali imposte o tasse, nonché di tributi, diritti ed oneri fiscali o di qualsiasi specie eventualmente gravanti sul Contratto.

## 5. Riserva di proprietà

## 6. Prezzi

## 7. Condizioni di pagamento

7.1 Il pagamento dovrà essere effettuato alle condizioni (termine, valuta) pattuite. Il pagamento si considera effettuato quando la somma entra nella disponibilità del Venditore presso la sua banca in Italia. Salvo diverso accordo, eventuali spese o commissioni bancarie dovute in relazione al pagamento saranno a carico del Compratore.

7.2 In caso di ritardo di pagamento rispetto alla data pattuita, il Compratore sarà tenuto a corrispondere al Venditore un interesse di mora pari al tasso d’interesse del principale strumento di rifinanziamento della Banca centrale europea, più sette punti percentuali, conformemente all’art. 4 del decreto legisl. n. 231 del 9 ottobre 2002 che attua la direttiva CE 35/2000. L’eventuale ritardo di pagamento superiore a 30 gg. dalla data indicata in fattura darà al Venditore il diritto di risolvere il contratto, con facoltà di trattenere la parte di prezzo pagata e di pretendere la restituzione dei prodotti forniti, a cura e spese del Compratore, oltre il risarcimento dell’eventuale danno.

7.3 Qualora il Venditore abbia motivo di temere che il Compratore non possa o non intenda pagare i Prodotti alla data pattuita, egli potrà subordinare la consegna dei Prodotti alla prestazione di adeguate garanzie di pagamento (ad es. fideiussione o garanzia bancaria). Inoltre, in caso di ritardi di pagamento, il Venditore potrà modificare unilateralmente i termini di pagamento di eventuali altre forniture e/o sospenderne l’esecuzione fino all’ottenimento di adeguate garanzie di pagamento.

8.1 Il Venditore si impegna a porre rimedio a qualsiasi difetto di conformità dei Prodotti a lui imputabile, verificatosi entro 1 anno dalla consegna dei Prodotti, purché lo stesso gli si stato notificato tempestivamente in conformità all’art. 4.3, fornendo dei Prodotti in sostituzione di quelli risultati difettosi.

8.2 Salvo il caso di dolo o colpa grave del Venditore, quest’ultimo sarà tenuto, in caso di difetto di conformità dei Prodotti, unicamente alla fornitura di Prodotti sostitutivi come previsto dall’art. 8.1. È inteso che la suddetta garanzia è assorbente e sostitutiva delle garanzie o responsabilità previste per legge, ed esclude ogni altra responsabilità del Venditore (sia contrattuale che extra contrattuale) comunque originata dai Prodotti forniti (ad es. risarcimento del danno, mancato guadagno, rimozione dei Prodotti difettosi, ecc.).

8.3 La garanzia è esclusa per le scelte inferiori alla prima e, per quanto riguarda vizi e/o difetti di natura palese (quali, tra gli altri, quelli di forma, dimensione, calibro, scelta e tonalità ecc.), quando il materiale è già stato posato.

8.4 In relazione ad eventuali azioni intraprese da consumatori in applicazione di norme nazionali di attuazione della direttiva europea 1999/44/CE del 25 maggio 1999 su taluni aspetti della vendita di beni di consumo e le garanzie, il Compratore accetta di assumersi l’esclusiva responsabilità per qualsiasi obbligazione possa nascere in tale contesto. Di conseguenza, le parti concordano espressamente di escludere ogni diritto di rivalsa da parte del Compratore nei confronti del Venditore in base alla direttiva sopra indicata ed il Compratore si impegna inoltre a tenere il Venditore indenne da qualsiasi azione di regresso fatta da eventuali successivi venditori della catena di distribuzione.

Per qualsiasi controversia derivante dal presente contratto o collegata allo stesso sarà e esclusivamente competente il Foro di Modena (Italia). Tuttavia, in deroga a quanto stabilito sopra, il Venditore ha comunque la facoltà di portare la controversia davanti al giudice competente presso la sede d’affari del Compratore.

## 9. Foro Competente

# Index

The Company

Technology

Sizes

Thicknesses

Surfaces

Porcelain stoneware

Ecologycare

Certifications

Quality and Safety

Ceramic of Italy

Fincibec Group

Campus

Engineering

Pools & Wellness

Facades

Raised Flooring

Technical Specifications

## Contents by collection

Archè	Geobrick
Ashley	Graphis
Azimuth	On Stage
Blade	Pietra Castello
Charisma	Pietre Naturali
Dicta	Tradition
Dolomite	Transalp
Esprit	Woodtime
Evolution	Yukon
Gamut	Major

## Contents by effect

WOOD - Legno

MARBLE - Marmo

STONE - Pietra

CONCRETE - Cemento

## Color Index

Color Index Major 20mm

## CONDITIONS GÉNÉRALES DE VENTE FINCIBEC S.P.A.

Avec siège social Sassuolo

<p><b>1. Avant-propos</b></p>	<p>1.1 Les présentes conditions générales, sauf dérogations spécifiquement concordées par écrit, règlent tous les contrats de vente actuels et futurs entre les parties. Les conditions générales éventuelles de l'acheteur ne trouveront pas application si non expressément acceptées par écrit et devront dans tous les cas être coordonnées avec les présentes conditions générales.</p> <p>1.2 Le contrat de vente est discipliné par la convention des Nations Unies sur la vente internationale de marchandises (Vienne 1980) et, pour les questions non couvertes par cette convention, de la loi italienne.</p>
<p><b>2. Caractéristiques du produit</b></p>	<p>2.1 Sauf accord différent écrit, le vendeur ne garantit pas l'uniformité et/ou la conformité à des échantillons éventuels pour ce qui est de la couleur, la tonalité et les nuances de couleur des produits. En outre, le vendeur ne garantit pas que les produits soient adaptés à un usage particulier, excepté les limites indiquées dans la fiche technique du vendeur du produit correspondant.</p> <p>2.2 Des différences qualitatives éventuelles entre les marges de tolérance usuelles du secteur et/ou normalement acceptées dans les rapports entre les parties seront considérées conformes au contrat.</p> <p>2.3 Le vendeur garantit la conformité du produit aux prescriptions techniques en vigueur en Italie. Toute caractéristique spécifiquement requise dans le pays de destination ne sera prise en compte que sur demande écrite de l'acheteur, qui devra préciser le contenu des prescriptions à observer.</p>
<p><b>3. Délais de livraison</b></p>	<p>3.1 Les conditions de livraison éventuellement concordées par les parties ont une valeur purement indicative. Toutefois, en présence d'un retard imputable au vendeur qui dépasserait 90 jours, l'acheteur pourra mettre fin au contrat en ce qui concerne le produit dont la livraison est retardée. On ne considère pas imputable au vendeur le retard pour force majeure (comme définie par l'art 9).</p> <p>3.2 Sauf cas de dol ou faute grave du vendeur, tout autre dédommagement du dommage pour livraison manquante ou retardée du produit est exclu.</p> <p>4.1 Sauf accord contraire, la livraison des marchandises s'entend Franco Usine (EXW), Incoterms 2010, et ceci même quand il est convenu que l'expédition ou partie de l'expédition est assurée par le vendeur.</p> <p>4.2 Dans tous les cas, quels que soient les termes de livraison concordés par les parties, il est expressément convenu que la livraison a lieu lors de la remise du produit au premier transporteur à l'établissement du vendeur. Les risques passent à l'acheteur au plus tard lors de la livraison au premier transporteur.</p> <p>4.3 Les réclamations éventuelles concernant l'état de l'emballage, la quantité, le nombre et caractéristiques extérieures des produits (vices apparents), devront être notifiées au vendeur par LRAR, dans les 8 jours date de réception des produits; en l'absence de cette notification l'acheteur perdra son droit de contester les vices susmentionnés. Les réclamations éventuelles concernant des défauts non identifiables par un contrôle soigné au moment de la réception (vices cachés) devront être notifiées au vendeur par LRAR dans les 8 jours date de la découverte du défaut et de toutes façons pas au-delà de 3 mois après la livraison<span> </span>; en l'absence de cette notification, l'acheteur perdra sa faculté de contester les vices susmentionnés .</p> <p>4.4 Toute réclamation dont l'art. 4.3 doit indiquer par écrit les raisons de la réclamation et les produits de référence. Là où l'acheteur fait valoir des défauts du produit, il doit envoyer au vendeur – lors de la notification de réclamation – des échantillons des produits défectueux dans la mesure nécessaire pour permettre de contrôler le défaut, sauf accord écrit différent.</p> <p>4.5 Il est entendu que les réclamations éventuelles ou les contestations ne donnent pas droit pour l'acheteur de suspendre ou retarder les paiements des produits objets de la contestation ni autres fournitures. Il est convenu que les produits livrés restent de la propriété du vendeur jusqu'au paiement complet.</p> <p>Sauf accord contraire, le prix des produits sera celui de la liste du vendeur en vigueur au moment de la réception de commande. Le prix s'entend pour remise Franco usine (EXW) y compris emballage normal, étant entendu que tout autre frais ou charge sera à la charge de l'acheteur. Les prix s'entendent au net de TVA, d'impôts et taxes, ainsi que cotisations, droits et charges fiscales ou tout autre charge grevant éventuellement le contrat.</p>
<p><b>5. Réserve de propriété</b></p> <p><b>6. Prix</b></p>	
<p><b>7. Conditions de paiement</b></p>	<p>7.1 Le paiement devra être effectué aux conditions (délais, valeur) fixées. Le paiement sera considéré effectué quand la somme est à disposition du vendeur à sa banque en Italie. Sauf accord différent, les frais ou commissions bancaires liés au paiement sont à charge de l'acheteur.</p> <p>7.2 En cas de retard de paiement par rapport à la date fixée, l'acheteur sera tenu à verser au vendeur un intérêt de pénalité égal au taux d'intérêt du principal instrument de refinancement de la banque centrale européenne, augmenté de sept points pourcentage conformément à l'art. 4 du décret législ. n. 231 du 9 octobre 2002 qui applique la directive CE 35/2000. Le retard éventuel de paiement dépassant 30 j après la date indiquée sur la facture donnera au vendeur le droit de résoudre le contrat avec faculté de retenir la part de prix déjà payée et de prétendre à la restitution des produits finis, aux soins et charge de l'acheteur, outre le dédommagement du dommage éventuel.</p> <p>7.3 Si le vendeur a une raison de craindre que l'acheteur ne peut pas ou ne veut pas payer les produits à la date fixée, il pourra conditionner la livraison des produits aux prestations de garanties adéquates de paiement (par ex. fidéjussions ou garantie bancaire). En outre en cas de retard de paiement, le vendeur pourra modifier unilatéralement les termes de paiement d'autres fournitures éventuelles et/ou suspendre l'exécution jusqu'à obtenir des garanties de paiement adéquates.</p>
<p><b>8. Garantie pour vices</b></p>	<p>8.1 Le vendeur s'engage à apporter remède à tout défaut de conformité des produits qui lui serait imputable, dans les une année date de livraison des produits, à condition que celui-ci lui ait été notifié à temps en conformité avec l'art. 4.3, en livrant des produits de remplacement des produits défectueux.</p> <p>8.2 Sauf le cas de dol ou faute grave du vendeur, ce dernier sera tenu en cas de défaut de conformité des produits, uniquement à la fourniture de produits de remplacement comme prévu par l'article 8.1. Il est entendu que cette garantie est absorbante et constitutive des garanties ou responsabilités prévues par la loi, et exclut toute autre responsabilité du vendeur (tant contractuelle qu'extracontractuelle) induite par les produits fournis (par ex.dédommagement, manque à gagner, retrait des produit défectueux etc.).</p> <p>8.3 La garantie est exclue pour les choix inférieurs au premier, et pour ce qui concerne les vices et/ou défauts de nature évidente (comme, entre autres, ceux de forme, dimension, calibre, choix et tonalité etc.), quand le matériel a déjà été posé.</p> <p>8.4 En ce qui concerne les actions éventuelles entreprises par les consommateurs en application de la directive européenne 1999/44/CE du 25 mai 1999 sur certains aspects de la vente de biens de consommation et les garanties, l'acheteur accepte d'assumer l'entière et exclusive responsabilité pour toute obligation susceptible de naître dans ce contexte. Par conséquent, les parties concordent expressément d'exclure tout droit de retour par l'acheteur envers le vendeur sur la base de la directive sus-indiquée, et l'acheteur s'engage en outre à tenir le vendeur indemne de toute action régressive faite pas les vendeurs éventuels suivants de la chaîne de distribution.</p> <p>Pour toute controverse dérivant du présent contrat ou liée à celui-ci, le tribunal compétent sera exclusivement celui de Modena (Italie). Toutefois, en dérogation à cette clause, le vendeur a la faculté de porter la controverse devant le juge compétent du siège de l'acheteur.</p>
<p><b>9. Tribunal compétent</b></p>	

## ALLGEMEINE VERKAUFSBEDINGUNGEN DER FIRMA FINCIBEC S.P.A.

Mit Sitz in Sassuolo

<p><b>1. Vorbemerkung</b></p>	<p>1.1 Die vorliegenden allgemeinen Verkaufsbedingungen regeln, außer bei eventuellen schriftlich vereinbarten Abweichungen, alle laufenden und zukünftigen Kaufverträge zwischen den Parteien. Eventuelle allgemeine Bedingungen der Käuferfirma finden auf die zukünftigen Beziehungen zwischen den Parteien keine Anwendung, wenn sie nicht ausdrücklich schriftlich anerkannt werden; diese sind in jedem Fall den vorliegenden Allgemeinen Geschäftsbedingungen anzupassen.</p> <p>1.2 Der Kaufvertrag wird durch das UN-Kaufrecht (Wien 1980) sowie, für Angelegenheiten, die nicht durch diese Konvention abgedeckt sind, vom italienischen Recht geregelt.</p>
<p><b>2. Merkmale der Erzeugnisse</b></p>	<p>2.1 Vorbehaltlich anderer schriftlicher Vereinbarungen garantiert die Verkäuferfirma nicht für die Einheitlichkeit und/oder die Übereinstimmung mit eventuellen Mustern bezüglich der Farbe, des Farbtons oder der Nuancierung der Erzeugnisse. Außerdem garantiert die Verkäuferfirma über die Angaben des technischen Datenblatts des betreffenden Erzeugnisses hinaus nicht dafür, dass die Erzeugnisse für einen spezifischen Gebrauch geeignet sind.</p> <p>2.2 Eventuelle Qualitätsunterschiede innerhalb der für den Sektor üblichen und/oder normalerweise zwischen den Parteien akzeptierten Toleranzgrenzen gelten als dem Vertrag entsprechend.</p> <p>2.3 Die Verkäuferfirma garantiert die Übereinstimmung der Erzeugnisse mit den in Italien derzeit geltenden technischen Vorschriften. Eventuelle Anforderungen, die im Bestimmungsland erforderlich sind, können nur auf vorherige schriftliche Anfrage der Käuferfirma, die den Inhalt der einzuhaltenden Vorschriften präzisieren muss, in Betracht gezogen werden.</p>
<p><b>3. Lieferzeiten</b></p>	<p>3.1 Die eventuell von den Parteien vereinbarten Lieferzeiten sind lediglich als Richtwert aufzufassen. Sollte jedoch eine von der Verkäuferfirma verschuldete Verspätung auftreten, die 90 Tage überschreitet, kann die Käuferfirma den Vertrag bezüglich jener Erzeugnisse kündigen, deren Lieferung sich verspätet. Die Verkäuferfirma ist nicht verantwortlich für eventuell Verspätungen, die aufgrund höherer Gewalt (wie in Art. 9 festgelegt) verursacht werden.</p> <p>3.2 Ausgenommen in Fällen von Vorsatz oder grober Fahrlässigkeit der Verkäuferfirma ist jeder weitere Schadenersatz für eine nicht erfolgte oder verspätete Lieferung der Erzeugnisse ausdrücklich ausgeschlossen.</p>
<p><b>4. Rückgabe der Lieferung- Reklamationen</b></p>	<p>4.1 Sofern vertraglich nicht anders vereinbart, wird die Ware ab Werk geliefert (EXW), Incoterms 2010, d.h. auch dann, wenn der Versand oder Teile davon von der Verkäuferfirma vorgenommen werden.</p> <p>4.2 Wie auch immer die Lieferzeiten zwischen den Parteien festgelegt sein sollten, wird ausdrücklich vereinbart, dass die Lieferung mit der Übergabe der Erzeugnisse an den ersten Transportunternehmer im Werk der Verkäuferfirma erfolgt. Die Risiken gehen auf die Käuferfirma über, sobald die Ware dem ersten Transportunternehmen übergeben wurde.</p> <p>4.3 Eventuelle Beanstandungen bezüglich des Zustandes der Verpackung, der Menge, der Anzahl oder des äußeren Erscheinungsbildes der Ware (sichtbare Schäden) müssen der Verkäuferfirma innerhalb von 8 Tagen nach Erhalt der Erzeugnisse mittels Einschreibebrief mit Rückantwortschein mitgeteilt werden; sollte diese Mitteilung nicht vorliegen, verfällt das Recht der Käuferfirma auf Beanstandung der oben genannten Schäden. Eventuelle Beanstandungen von Defekten, die durch eine genau Kontrolle bei Erhalt der Lieferung nicht sofort erkennbar sind (versteckte Schäden), müssen der Verkäuferfirma mittels Einschreibebrief mit Rückantwortschein innerhalb von 8 Tagen nach Schadenserkennung und nicht später als drei Monate nach Lieferung mitgeteilt werden; sollte diese Mitteilung nicht vorliegen, verfällt das Recht der Käuferfirma auf Beanstandung der oben genannten Schäden.</p> <p>4.4 Jede Beanstandung gemäß Art. 4.3 muss die Gründe für die Reklamation sowie das Erzeugnis, auf welches sie sich bezieht, schriftlich darlegen. Sofern die Käuferfirma sich auf die Defekte der Erzeugnisse beruft, muss sie der Verkäuferfirma - bei der Zustellung der Reklamation - Muster der defekten Erzeugnisse in einer Menge zusenden, die es möglich macht, den Defekt zu überprüfen, sollten keine abweichende schriftliche Vereinbarung getroffen worden sein.</p> <p>4.5 Eventuelle Beanstandungen oder Reklamationen geben der Käuferfirma nicht das Recht, die Zahlungen bezüglich der entsprechenden Ware sowie anderer Lieferungen auszusetzen oder zu verzögern. Es wird vereinbart, dass die gelieferten Erzeugnisse Eigentum der Verkaufsfirma bleiben, bis die Bezahlung der gesamten Verkaufssumme erfolgt. Sofern nicht anders vereinbart, entspricht der Preis der Ware der Preisliste der Verkäuferfirma, die zum Zeitpunkt des Auftragseingangs gültig ist. Der Preis versteht sich ab Werk (EXW) einschließlich der normalen Verpackung; jede weitere Ausgabe oder Auflage geht zu Lasten der Käuferfirma. Die Preise sind ohne Mehrwertsteuer, eventuelle Steuern oder Abgaben, sowie ohne Gebühren und Besteuerung angegeben und ebenso ohne jede andere vertragliche Belastung.</p>
<p><b>5. Eigentumsvorbehalt</b></p> <p><b>6. Preise</b></p>	
<p><b>7. Zahlungsbedingungen</b></p>	<p>7.1 Die Zahlung muss zu den vereinbarten Bedingungen (Frist, Währung) erfolgen. Die Zahlung gilt als erfolgt, wenn der Betrag der Verkäuferfirma bei seiner Bank in Italien zur Verfügung steht. Sofern nicht anders vereinbart, gehen eventuell geforderte Ausgaben oder Bankgebühren in Zusammenhang mit der Bezahlung auf Kosten der Käuferfirma.</p> <p>7.2 Bei Zahlungsverzögerung hinsichtlich des festgesetzten Zahlungstermins muss die Käuferfirma der Verkäuferfirma tarifvertragliche Zinsen bezahlen, die nach Art. 4 des italienischem Gesetzesdekrets 231 vom 9. Oktober 2002 berechnet werden, welches die Richtlinie EG 35/2000 umsetzt. Die eventuelle Zahlungsverzögerung von mehr als 30 Tagen ab dem Rechnungsdatum berechtigt die Verkäuferfirma zur Kündigung des Vertrags mit der Befugnis, den Teil des gezahlten Preises einzubehalten und die Rückgabe der gelieferten Waren auf Betreiben und Kosten der Käuferfirma sowie die Entschädigung für den eventuell entstandenen Schaden zu verlangen.</p> <p>7.3 Sollte die Verkäuferfirma Anlass zu der Befürchtung haben, dass die Käuferfirma die Waren zum vereinbarten Termin nicht bezahlen kann oder will, kann er die Lieferung der Erzeugnisse von geeigneten Bürgschaften abhängig machen ( z.B. Kautionen oder Bankbürgschaften). Außerdem kann die Verkäuferfirma im Falle von Zahlungsverzögerungen einseitig die Zahlungsbedingungen für eventuelle andere Lieferungen ändern und/oder die Ausführung unterbrechen, bis angemessene Bürgschaften vorliegen.</p>
<p><b>8. Garantie im Schadensfall</b></p>	<p>8.1 Die Verkäuferfirma verpflichtet sich, alle Schäden der Erzeugnisse auszubessern, die in ihrer Verantwortung liegen und innerhalb von eine Jahre nach Lieferung der Ware aufgetreten sind, sofern ihm diese rechtzeitig und in Übereinstimmung mit Art. 4.3 mitgeteilt wurden, indem die Verkäuferfirma Ersatz für die defekten Waren liefert.</p> <p>8.2 Ausgenommen in Fällen von Vorsatz oder grober Fahrlässigkeit der Verkäuferfirma ist diese bei Werksfehlern der Erzeugnisse nur zur Lieferung der Ersatzware gemäß Art. 8.1 verpflichtet. Die genannte Garantie ist Teil der gesetzlich vorgesehenen Garantie oder Verantwortung und schließt jede andere Verantwortung (sowohl vertraglich als auch außervertraglich) seitens der Verkäuferfirma für die gelieferten Produkte aus ( z. B. Schadenersatz, Verdienstausfall, Entfernung der defekten Erzeugnisse usw.).</p> <p>8.3 Die Garantie gilt nicht für Entscheidungen, die dem zuvor Genannten untergeordnet sind, und ebenfalls nicht für offensichtliche Schäden und/oder Defekte (u.a. hinsichtlich der Form, Größe, Stärke, Qualität und des Farbtons), wenn das Produkt bereits verlegt wurde. 8.4 Hinsichtlich eventuell von Verbrauchern ergriffenen Maßnahmen unter Anwendung der nationalen Gesetze zur Umsetzung der europäischen Richtlinie 1999/44/EG vom 25. Mai 1999 zu einigen Aspekten des Verbrauchsgüterkaufs und der Garantien akzeptiert die Käuferfirma, die alleinige Verantwortung für jede Verpflichtung zu übernehmen, die in diesem Zusammenhang entstehen könnte. Demzufolge vereinbaren die Parteien ausdrücklich, jeden Regress seitens der Käuferfirma gegenüber der Verkäuferfirma auf der Grundlage der o.g. Richtlinie auszuschließen, wobei die Käuferfirma sich außerdem verpflichtet, die Verkäuferfirma bei jeder Regressaktion schadlos zu halten, die von eventuellen nachfolgenden Verkäufern innerhalb der Lieferkette ausgeführt wird. Für jede Rechtstreitigkeit im Bezug auf den vorliegenden Vertrag oder in Zusammenhang mit demselben ist ausschließlich das Gericht von Modena (Italien) zuständig. Trotz dieser festgesetzten Bestimmung kann die Verkäuferfirma die Streitfrage vor den beim Sitz der Käuferfirma zuständigen Gerichtshof bringen.</p>
<p><b>9. Gerichtsstand</b></p>	

# Index

The Company
Technology
Sizes
Thicknesses
Surfaces
Porcelain stoneware
Ecologycare
Certifications
Quality and Safety
Ceramic of Italy
Fincibec Group
Campus
Engineering
Pools & Wellness
Facades
Raised Flooring
Technical Specifications

## Contents by collection

Archè	Geobrick
Ashley	Graphis
Azimuth	On Stage
Blade	Pietra Castello
Charisma	Pietre Naturali
Dicta	Tradition
Dolomite	Transalp
Esprit	Woodtime
Evolution	Yukon
Gamut	Major

## Contents by effect

WOOD - Legno
MARBLE - Marmo
STONE - Pietra
CONCRETE - Cemento

## Color Index

Color Index Major 20mm



---

**NOTE** - NOTE NOTES - NOTIZEN - NOTAS

.....

.....

.....

.....

.....

.....

.....

.....

.....

.....

.....

.....

.....

.....

.....

.....

.....

.....

.....

.....

.....

.....

.....

.....







MONOCIBEC  
Via Valle d'Aosta, 47  
41049 Sassuolo (MO) Italy  
Tel. +39 0536 861300  
Fax Italia +39 0536 861400  
Fax Export Dept. +39 0536 861450  
info@monocibec.it  
www.monocibec.it

FINCIBEC S.p.A.  
Sede legale: Via Valle d'Aosta, 47  
41049 Sassuolo (Mo) Italy  
Gruppo Fire S.R.L.

FINCIBEC USA INC.  
420 Columbus Avenue  
Valhalla N.Y. 10595 USA



Fincibec S.p.A è socio di:

